

PNEG-785
06/16/03
Rev. No. 0

8" Center Drive Transport Auger

8" Center Drive Transport Auger

Assembly & Operation Manual

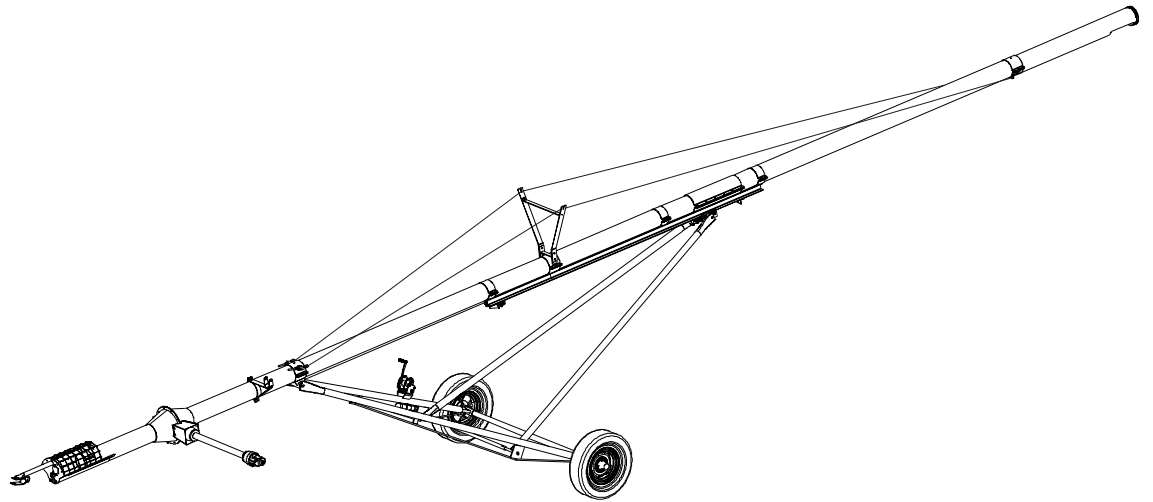

PNEG-785
06/16/03
Rev. No. 0

SAFETY DECALS

The Safety Decals listed below are included with the auger. The following page shows the locations of the decals on the auger.

Inspect all decals and replace any that are illegible, worn, or missing. Contact your dealer or the factory to order replacement decals.

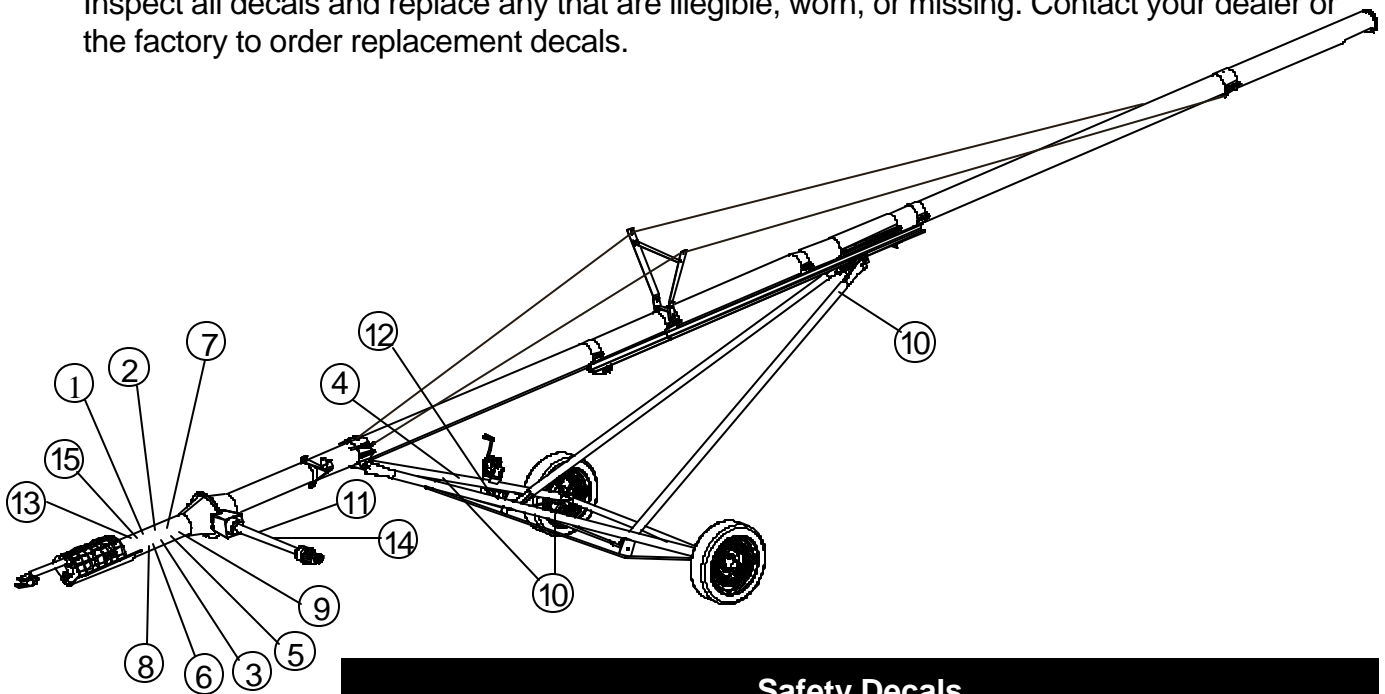

Safety Decals				
Ref. #	Part #	Qty.	Description	Size
1	DC-1446	1	Caution—General Statements 1-12	8-1/4" x 4-1/8"
2	DC-1412	1	Danger—Electrocution	8" x 3-3/8"
3	DC-1419	1	Warning—Hydraulic Fluid Leaking	8" x 3-3/8"
4	DC-1421	1	Warning—Winch Handle	7" x 3"
5	DC-1409	1	Danger—Falling Auger	4-1/2" x 6-1/2"
6	DC-1416	5	Danger—Rotating Auger	4-1/2" x 5-1/2"
7	DC-1410	1	Danger—Never Disassemble the Auger	4-1/2" x 2-1/8"
8	DC-1418	1	Safety First	4-7/8" x 3-1/2"
9	DC-1445	1	Warning—Caution Transporting Auger	6" x 3-1/2"
10	DC-1447	2	Warning—Pinch Points	7" x 3"
11	DC-1375	1	Danger—Rotating Driveline	4-3/8" x 5-3/4"
12	DC-1425	1	Manual Inside	7" x 1-1/4"
13	DC-1414	1	Caution—PTO Driveline Guidelines	7" x 5-1/4"
14	DC-1413	1	Grease Here	2" x 1"
15	DC-1411	1	Danger—Shear Point	4-1/2" x 2-1/16"
16	DC-994	1	Danger—Shear Point (Inside of Belt Guard)	4-1/2" x 2"
17	DC-995	1	Warning—Shear Point	4-1/2" x 2"
18	DC-1379	1	Notice	7-3/8" x 5-1/8"
19	DC-1448	1	Warning--Hitch	7" x 3"

SAFETY DECALS

①

NOTICE	
<ol style="list-style-type: none"> 1. READ AND UNDERSTAND THE INSTALLATION & OPERATION MANUAL AND ALL SAFETY INSTRUCTIONS BEFORE OPERATING EQUIPMENT. 2. DO NOT OPERATE WHILE UNDER THE INFLUENCE OF DRUGS OR ALCOHOL. 3. DO NOT OPERATE UNLESS ALL SAFETY EQUIPMENT, SWITCHES, GUARDS AND SHIELDS ARE SECURELY IN PLACE AND OPERATIONAL. 4. BE SURE EVERYONE IS CLEAR OF THE EQUIPMENT BEFORE ATTEMPTING TO OPERATE OR MOVING THE MACHINE. 5. ALLOW ONLY TRAINED PERSONNEL IN THE OPERATING AREA. 6. KEEP HANDS, FEET, HAIR AND CLOTHING AWAY FROM MOVING PARTS. 7. DISCONNECT AND LOCKOUT POWER BEFORE ADJUSTING OR SERVICING. 8. ELECTRICAL WIRING OR SERVICE WORK MUST BE PERFORMED BY A QUALIFIED ELECTRICIAN. IT MUST MEET ALL STATE AND LOCAL ELECTRICAL CODES. 9. EMPTY AUGER AND LOWER TO TRANSPORT POSITION BEFORE TRANSPORTING. 10. MAKE CERTAIN ALL ELECTRIC MOTORS ARE GROUNDED. 11. NEVER MOVE MACHINE MANUALLY. ALWAYS USE A TOWING VEHICLE. 12. KEEP CHILDREN AWAY FROM WORK AREA AT ALL TIMES. 	DC-1446

②

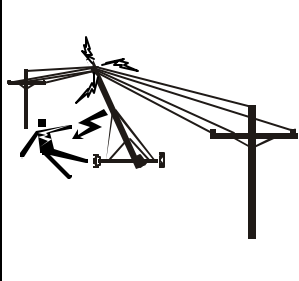
	<p style="text-align: center; font-size: 1.2em; font-weight: bold;">⚠ DANGER</p> <p style="text-align: center; font-weight: bold;">ELECTROCUTION!! STAY CLEAR OF POWER LINES!</p> <ul style="list-style-type: none"> • THIS EQUIPMENT IS NOT INSULATED FROM ELECTRIC SHOCK. • KEEP EQUIPMENT AWAY FROM POWER LINES. • ELECTROCUTION CAN OCCUR WITH OR WITHOUT DIRECT CONTACT. <p style="text-align: center; font-weight: bold; font-size: 0.8em;">FAILURE TO HEED WILL RESULT IN SERIOUS INJURY OR DEATH!</p> <p style="text-align: right; font-size: 0.7em;">DC-1412</p>
--	--

③

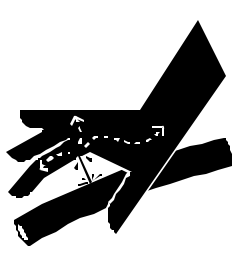
	<p style="text-align: center; font-size: 1.2em; font-weight: bold;">⚠ WARNING</p> <p style="font-size: 0.8em;">HYDRAULIC FLUID LEAKING UNDER PRESSURE CAN PENETRATE SKIN. IF THIS HAPPENS, SEEK MEDICAL ATTENTION IMMEDIATELY. ALWAYS RELEASE PRESSURE FROM HYDRAULIC LINES BEFORE DISCONNECTING. ALWAYS INSPECT THE HYDRAULIC LINES BEFORE AND AFTER USING THIS EQUIPMENT AND PERFORM ANY NECESSARY MAINTENANCE ON THE HYDRAULIC SYSTEM BEFORE OPERATING.</p> <p style="text-align: center; font-weight: bold; font-size: 0.8em;">FAILURE TO HEED WILL RESULT IN SERIOUS INJURY OR DEATH!</p> <p style="text-align: right; font-size: 0.7em;">DC-1419</p>
---	--

④

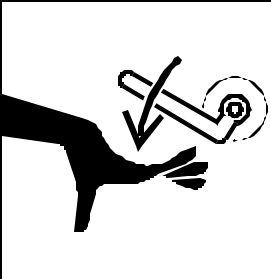
	<p style="text-align: center; font-size: 1.2em; font-weight: bold;">⚠ WARNING</p> <p style="font-size: 0.8em;">WINCH HANDLE CAN MOVE WITHOUT WARNING CAUSING SEVERE INJURY.</p> <ul style="list-style-type: none"> • NEVER RELEASE THE WINCH HANDLE UNTIL THE LOCK IS SECURELY IN PLACE. • NEVER RELEASE WINCH LOCK BEFORE MANUALLY SECURING WINCH HANDLE WHEN LOWERING HOPPER. • NEVER LEAVE HOPPER ON THE GROUND WHEN RAISING OR LOWERING THE AUGER. DOING SO COULD DAMAGE THE HOPPER WHEELS. <p style="text-align: right; font-size: 0.7em;">DC-1421</p>
---	--

SAFETY DECALS

⑤

⚠ DANGER

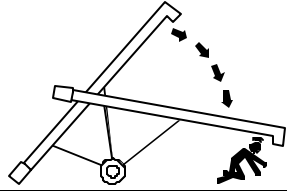

FALLING AUGER CAN CRUSH OR KILL!

ALWAYS SECURE INTAKE END SO THAT THE AUGER CANNOT FALL.

EMPTY THE AUGER BEFORE ATTEMPTING TO TRANSPORT IT.

NEVER PUSH THE UNDERCARRIAGE. ALWAYS USE PROPER TRANSPORTING METHODS.

USE CAUTION WHEN LIFTING THE INTAKE END. NEVER LIFT HIGHER THAN THE VEHICLE TOW BAR. DO NOT RELEASE UNTIL AUGER IS SECURELY ATTACHED TO THE TOW BAR OR ON THE GROUND.

LOWER THE AUGER FOR TRANSPORTING IMMEDIATELY AFTER MOVING IT AWAY FROM THE GRAIN STORAGE BIN.

FAILURE TO HEED WILL RESULT IN SERIOUS INJURY OR DEATH!

DC-1409

⑥

⚠ DANGER



ROTATING AUGER!

- DISCONNECT AND LOCKOUT POWER BEFORE SERVICING, ADJUSTING OR CLEANING.
- KEEP HANDS, FEET, HAIR AND LOOSE CLOTHING AWAY FROM ROTATING AUGER AND MOVING PARTS AT ALL TIMES.
- NEVER REMOVE OR MODIFY GUARDS OR SHIELDS.

FAILURE TO HEED WILL RESULT IN SERIOUS INJURY OR DEATH!

DC-1416

⑦



⚠ DANGER

NEVER DISASSEMBLE THE AUGER WITHOUT SUPPORTING IT WITH AN OVERHEAD HOIST. LOOSE COMPONENTS MAY CAUSE THE AUGER TO COLLAPSE, IF NOT SUPPORTED.

FAILURE TO HEED WILL RESULT IN SERIOUS INJURY OR DEATH.

DC-1410

⑧

GRAIN KING **1st**

SAFETY

THROUGH GRAIN KING'S "SAFETY 1ST" PROGRAM, CUSTOMERS CAN ORDER SAFETY COMPONENTS **FREE OF CHARGE!** SHOULD YOU EVER NEED GUARDS, SHIELDS, SAFETY DECALS OR OWNER/OPERATOR MANUALS, SIMPLY CONTACT GRAIN KING, AND WE WILL SUPPLY YOU WITH THEM **FREE OF CHARGE!**

JUST CALL:

(618) 542-9197

At Grain King, safety is NO ACCIDENT!

DC-1418

SAFETY DECALS

⑨

NOTICE

**USE CAUTION WHEN TRANSPORTING AUGER!
WIDTH EXCEEDS 8' 6".**

TAKE PROPER PRECAUTIONS WHEN
TRAVELING ON PUBLIC ROADS.

USE CAUTION WHEN NEAR OTHER VEHICLES,
PEDESTRIANS, ANIMALS AND OBJECTS
ON THE ROAD.

DC-1445

⑩



WARNING

KEEP HANDS, FEET, HAIR AND LOOSE CLOTHING AWAY FROM MOVING PARTS AND PINCH POINTS WHEN RAISING AND LOWERING THE AUGER.

FAILURE TO HEED WILL RESULT IN SERIOUS INJURY OR DEATH!

DC-1447

⑪

DANGER



ROTATING DRIVELINE CAN CAUSE SEVERE INJURY OR DEATH!

- KEEP AWAY FROM ROTATING DRIVELINE.
- KEEP LOOSE CLOTHING AWAY FROM ROTATING DRIVELINE.
- KEEP ALL GUARDS IN PLACE.
- BE SURE DRIVELINE IS SECURELY CONNECTED TO THE AUGER AND TRACTOR.
- THE DRIVELINE GUARDS MUST BE FREE TO TURN ON THE DRIVELINE.

FAILURE TO HEED WILL RESULT IN SERIOUS INJURY OR DEATH!

DC-1375

⑫

MANUAL INSIDE MANUAL INSIDE MANUAL INSIDE MANUAL INSIDE

DC-1425

⑬

NOTICE

- PLACE AUGER IN OPERATING POSITION BEFORE ATTACHING PTO DRIVELINE TO AGRICULTURAL TRACTOR ONLY.
- NEVER MOVE THE AUGER FROM OPERATING POSITION BEFORE DETACHING THE PTO DRIVELINE FROM THE TRACTOR PTO.
- MOVING THE AUGER WITH THE PTO DRIVELINE ATTACHED TO THE TRACTOR WILL CAUSE DAMAGE TO THE PTO DRIVELINE.
- THIS IS CONSIDERED A MISUSE OF THE EQUIPMENT. ANY MISUSE OF THE EQUIPMENT MAY VOID THE WARRANTY.

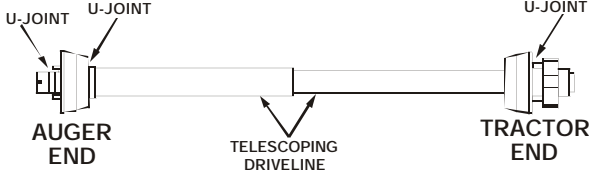

AUGER END TELESCOPING DRIVELINE TRACTOR END

DC-1414

⑭

GREASE



HERE

DC-1413

SAFETY DECALS

15



⚠ DANGER

SHEAR POINT
KEEP FINGERS, HANDS, HAIR AND LOOSE CLOTHING AWAY FROM MOVING PARTS.
FAILURE TO HEED WILL RESULT IN SERIOUS INJURY OR DEATH!

DC-1411

16



⚠ DANGER

SHEAR POINT
Keep hands clear of moving parts. Do not operate with guard removed. Disconnect and lockout power before servicing.

DC-994

17



⚠ WARNING

Shear point. Keep hands clear of moving parts. Do not operate with guard removed. Disconnect and lockout power before servicing.

DC-995

18

NOTICE

1. READ AND UNDERSTAND THE OPERATOR'S MANUAL AND ALL SAFETY INSTRUCTIONS.
2. DO NOT OPERATE WHILE UNDER THE INFLUENCE OF DRUGS OR ALCOHOL.
3. DO NOT OPERATE UNLESS ALL SAFETY EQUIPMENT, SWITCHES, GUARDS AND SHIELDS ARE SECURELY IN PLACE AND OPERATIONAL.
4. ALLOW ONLY TRAINED AUTHORIZED PERSONNEL IN THE OPERATING AREA.
5. ANY ELECTRICAL WIRING OR SERVICE WORK MUST BE PERFORMED BY A QUALIFIED ELECTRICIAN. IT MUST MEET ALL STATE AND LOCAL ELECTRICAL CODES.
6. DO NOT ALLOW CHILDREN IN THE AREA OF OPERATION.
7. KEEP HANDS, FEET AND CLOTHING AWAY FROM MOVING PARTS.
8. DISCONNECT AND LOCKOUT POWER BEFORE MAKING ANY ADJUSTMENTS OR PERFORMING ANY SERVICE WORK.
9. DISCONNECT POWER PRIOR TO RESETTING ANY MOTOR OVERLOAD.
10. MAKE CERTAIN ALL ELECTRIC MOTORS ARE GROUNDED.
11. REPLACE ALL WORN OR DAMAGED LABELS IMMEDIATELY.

DC-1379

19

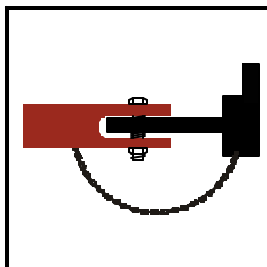

⚠ WARNING

HITCH MAY COME LOOSE IF NOT SECURELY FASTENED. HITCH BOLT SHOULD NOT BE LESS THAN 3/4 INCH IN DIAMETER. DAMAGE TO PROPERTY MAY OCCUR.

DC-1449

NOTES

For the purpose of this manual, if you stand at the intake end of the auger, and are looking straight ahead at the discharge end, your left is the left side of the auger; your right is the right side of the auger.

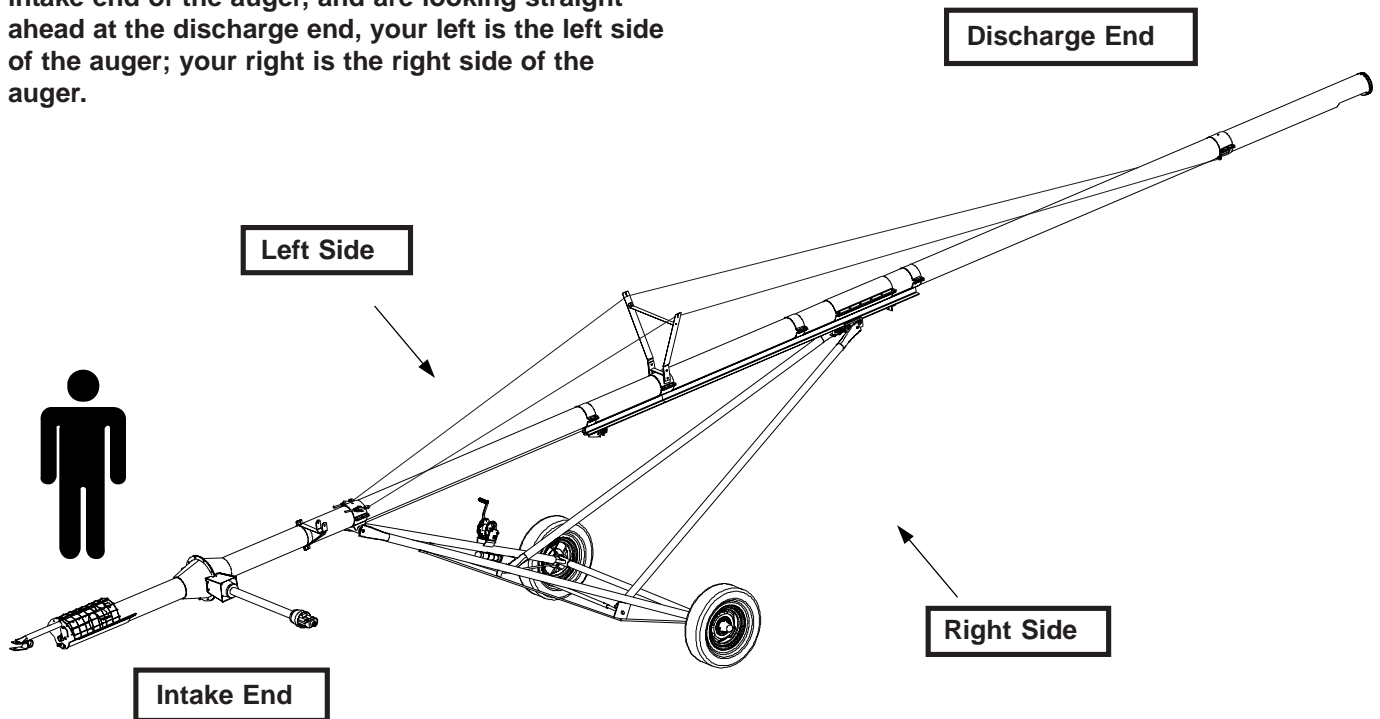

1. General information

- A. We reserve the right to improve our product whenever possible and practical to do so. We reserve the right to change, improve and modify products at any time without obligation to make changes, improvements and modifications on equipment sold previously.
- B. The Center Drive Transport Augers have been designed and manufactured to give years of dependable service. The care and maintenance of this machine will affect the satisfaction and service obtained. By observing the instructions and suggestions we have recommended, the owner should receive competent service for many years. If additional information or assistance should be required, please contact the manufacturer or your local dealer.
- C. When receiving merchandise, it is important to check both the quantity of parts and their descriptions with the packing list enclosed within each package. All claims for freight damage or shortage must be made by the consignee within ten (10) days from the date of the occurrence of freight damage. The consignee should accept the shipment after noting the damage or loss.

2. Capacity

- A. The capacities of augers or screw conveyers varies greatly under varying conditions. The following factors play a role in the performance of the auger:
 - Speed
 - Angle of operation
 - Moisture content
 - Amounts of foreign matter
 - Different materials
 - Methods of feeding
- B. An auger operating at a 45° incline might experience 20% less capacity than an auger operating horizontally. Twenty-five percent (25%) moisture could cut capacity by as much as 40% under some conditions.

3. Tractor Requirements

- A. The Center Drive portable auger was designed for use with a tractor meeting the following requirements:
1. 540 RPM Power Take Off (PTO)
 2. Adjustable Drawbar
 3. One (1) hydraulic control circuit for lifting the main auger. Minimum pressure of 1800 to 2000 PSI.

4. PTO Driveline

- A. The PTO driveline will be attached to the tractor after placement of the auger. Refer to the **Startup** section of this manual for more information.
- B. The PTO driveline furnished with the auger is equipped with a "Spring-Lok" coupler at the tractor end. The coupler is spring loaded and will fit the standard 1-3/8" x 6" spline PTO output shaft from the tractor.
- C. The PTO driveline is equipped with a shear bolt at the tractor connection. The shear bolt protects the auger from damage if the auger becomes plugged or subjected to high loads.
- D. Do not exceed the maximum recommended operating length of the PTO driveline.

5. Hydraulic Components - Optional

- A. The hydraulic components received with your Center Drive Transport Auger were selected to deliver the most efficient and economical use.

NOTE

Any parts needing replacement should be replaced with parts of the same type and size. Immediately replace any hoses or fittings that develop leaks. For more information, refer to the *Maintenance* section of this manual.

▲ WARNING

Keep all hydraulic lines away from moving parts. Damaged lines can cause damage to the auger and cause serious bodily injury to the operator. Escaping oil can penetrate skin.

- B. Center Drive Transport Augers with the *optional hydraulic lift* come with the following standard equipment:
- Hydraulic cylinder
 - Shut-off valve
 - Fittings
 - Hydraulic line from the cylinder to the tractor

Excluded are the fittings necessary to attach the hose to the tractor and a 1/2" female pipe thread tractor fitting required to fit the shut-off valve.

- C. The hydraulic cylinder includes a restrictor that limits the speed of operation and a vent plug which is located in the rod end of the cylinder.

6. Hydraulic Shut-Off Valve - Optional

- A. The hydraulic shut-off valve is located at the end of the hydraulic hose that connects the tractor to the hydraulic line running to the lift cylinder.
- B. Be sure that the shut-off valve is fully open before you raise or lower the auger.
- C. Make sure that the valve is closed at all other times. This will prevent possible leak-down or inadvertent hydraulic operation.

⚠ WARNING

Never connect or disconnect hydraulic parts when there is pressure within the system. Hydraulic systems are highly pressurized. Hydraulic oil that escapes, even through invisible pinhole-sized leaks, can penetrate body tissues and cause **SERIOUS INJURY**.

Look for leaks using a piece of wood or cardboard. **NEVER** use your hands or other parts of your body.

When reassembling, be certain that all connections are tight. If you are injured by hydraulic oil escaping under pressure, see a doctor immediately. Serious infection or reaction may occur if medical attention is not received at once.

7. Main Auger Drive Information

- A. Secure auger to the ground during operation.
- B. During operation, ensure the tractor is perpendicular to the auger.

⚠ DANGER

Stop the engine and lockout the power source whenever the equipment must be serviced or adjusted.

Do not use a PTO driveline without a rotating shield in good working order that can be turned freely on the shaft.

Be sure to securely attach the PTO driveline to the auger and the tractor.

Do not exceed the recommended distance from the end of the tractor PTO to the hitch pin.

NEVER start the tractor unless power to PTO is OFF.

Stay out of designated hazard areas of an operating PTO. Observe restricted work areas.

Do not operate unless **ALL** safety shields and devices are in place.

Be certain to close **ALL** the clean-out doors and inspection doors in the main auger hopper before operating the auger.

NOTES

1. Layout Auger Housing.

- A. Layout the auger housing on an open area of level ground that is accessible to a chain hoist or another lifting device. The area needs to be large enough to accommodate the auger being laid out at full length.
- B. Assembling the undercarriage will be easier if you place the tubes on stands or saw horses. Make sure the stands or saw horses are strong enough to support the weight of the auger tubes and flighting. We recommend 36" tall stands or saw horses. Assembly tables will be helpful as well.
- C. Separate and sort each hardware bag by size and place on the assembly table.
- D. Lay the sections of the tube assembly in the approximate positions shown for your size auger in the diagram below.

32' Auger

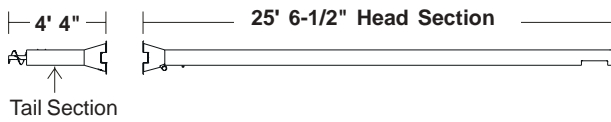

37' Auger

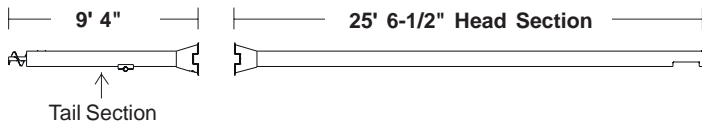

42' Auger

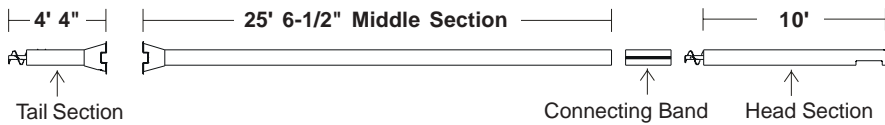

52' Auger

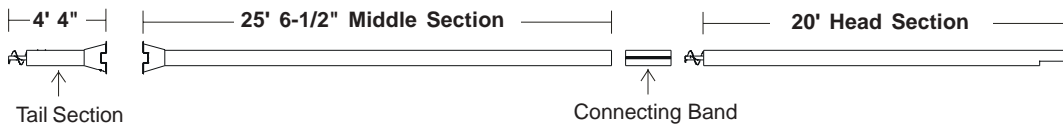

62' Auger

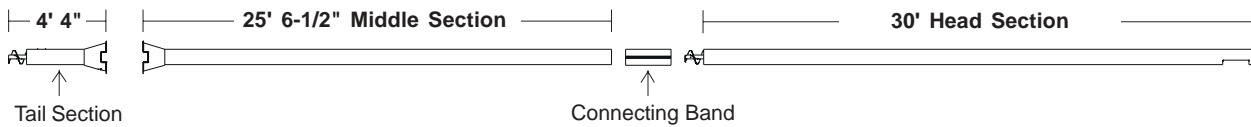

72' Auger

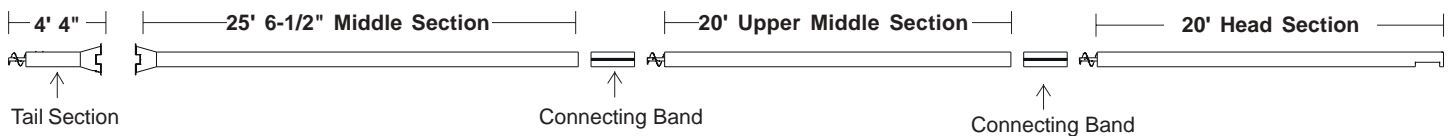

2. Gearbox Preparation

NOTE

When shipped, the gearbox is set up to be installed with the output shaft on the right side of the auger. The gearbox can be set up for right or left hand side operation using a PTO drive. **ELECTRIC DRIVES MUST BE OPERATED FROM THE RIGHT HAND SIDE.** To set the gear box up for left hand operation, turn the street el so it points up when installed in the bell housing.

CAUTION

THE GEARBOX IS SHIPPED WITHOUT OIL! FILL WITH LUBRICANT BEFORE USE.

A. Filling the Gearbox with Oil.

1. Remove the fill plug from the street elbow on the gearbox.
2. Fill the gearbox until oil is visible in the elbow when the gearbox is level. For temperatures between 40° F and 120° F, use non-foaming SAE 85W-90. For temperatures below 40° F, use SAE 80.
3. Replace the fill plug onto the street elbow.

CAUTION

Do not overfill the gearbox! Too much oil will cause pressure build up, which may damage the gearbox seals.

3. Bell Flight and Housing Section Assembly

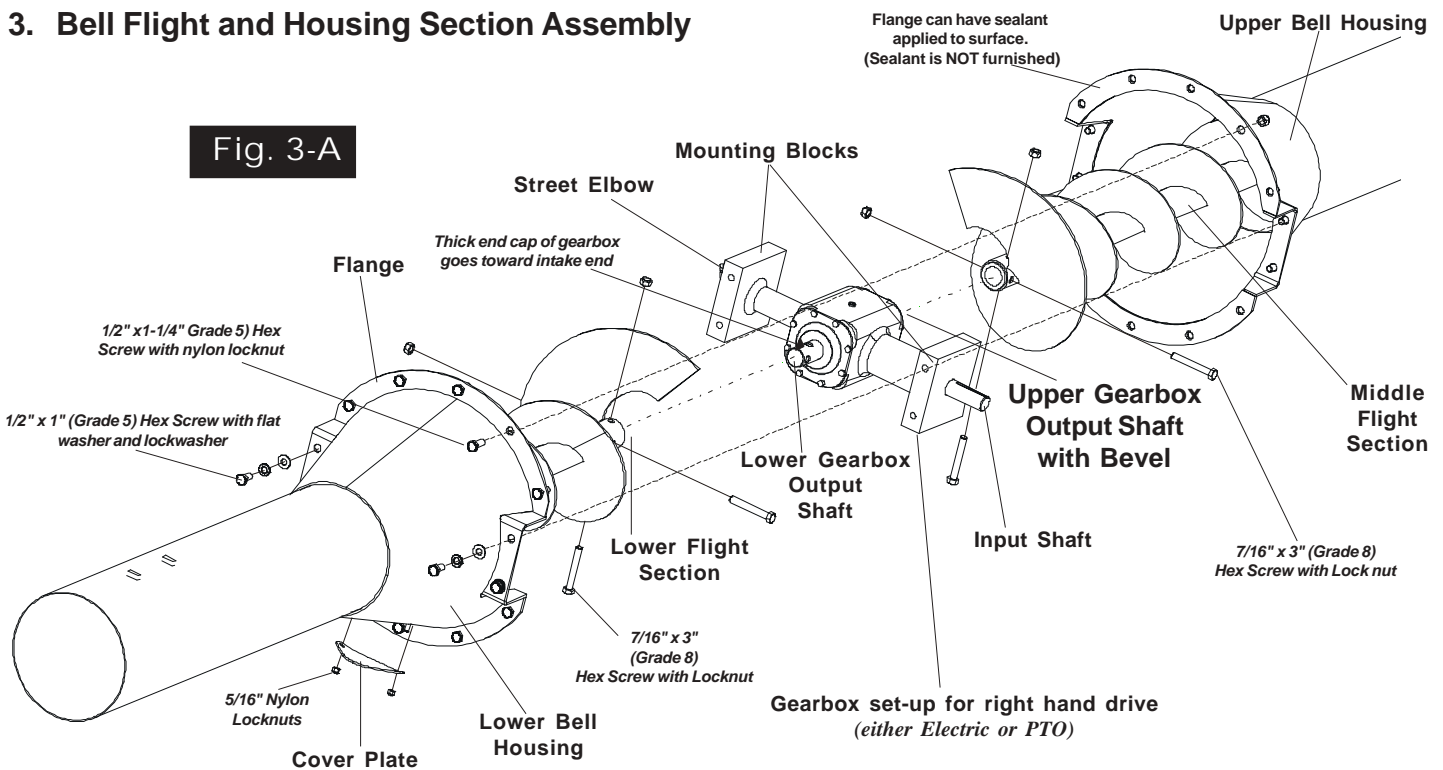

NOTE

For the next step, use the bolts and locknuts included in the separately packaged flight connecting bolt kit.

- A. **Bolt the beveled upper gearbox output shaft** to the middle flight section (head flight section for 32' models). Use two (2) 7/16" x 3" (Grade 8) hex head cap screws and stover type locknuts. (See Fig. 3-A.)
- B. Attach the gearbox to the upper bell housing.
 1. Slide the gearbox mounting blocks into the notches in the upper bell housing.
 2. Bolt the housing to the gearbox with four (4) 3/8" x 1" (Grade 5) hex head capscrews with lockwashers.

3. Bell Flight and Housing Section Assembly (Cont'd)

NOTE

When attaching the flight sections to the gearbox be sure to align the flight ends so they line up on the same side of the gearbox for proper flight balance (See Fig. 3-B).

- C. Bolt the lower gearbox output shaft to the flighting in the tail housing section using two (2) 7/16" x 3" (Grade 8) hex head cap screws and stover type lock nuts.
- D. Attach the lower bell housing to the gearbox.
 - 1. Slide the tail section forward so the slots in the lower bell housing slide over the mounting blocks on the gearbox.
 - 2. Bolt the housing to the gearbox with four (4) 3/8" x 1" hex head capscrews with lockwashers.
- E. Bolt the bell housing flanges together using ten (10) 1/2" x 1-1/4" (Grade 5) hex head bolts and nylon locknuts.

NOTE

For ELECTRIC DRIVE AUGERS, refer to motor mount frame in 26-B on page 37.

- F. Bolt the bell access cover plate to the lower bell housing with two (2) 5/16" nylon locknuts. (See Fig. 3-A)

NOTE

If your auger is equipped with optional INTERNAL BEARINGS, go directly to step 4 on Page 14.

- G. Connecting the Middle and Head Sections on 42' - 72' Models.

- 1. Slide the connecting band onto the end of one of the auger housing tubes sections to be assembled.
(32' & 37' Not Applicable)

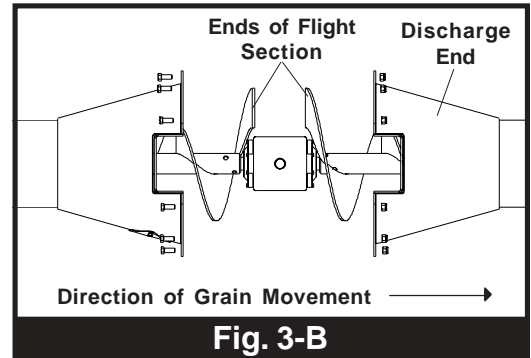

2. Bolt the middle flight section to the head flight section, using two (2) 7/16" x 3" hex head capscrews (Grade 8) and stover type lock nuts. The middle flight section will overlap the head flight section approximately one inch on the side facing the discharge end. For easier assembly, coat the connecting stubs with anti-seize lubricant or grease. (See Fig. 3-D.)
3. Butt the head and middle tube housing sections together. Position the connecting band so it is positioned equally over both the tubes. Secure the connecting band with six (6) 3/8" x 1-1/2" (grade 5) hex bolts and nylon lock nuts. (See Fig. 3-E.)
4. For 72' augers repeat steps G1-G3 for connecting the head sections and the 72' middle sections.

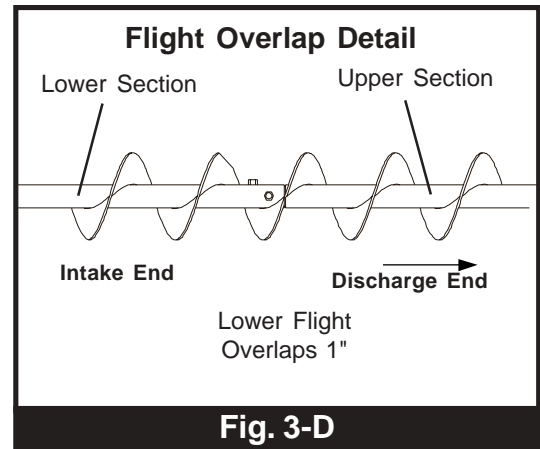

Fig. 3-D

NOTE

On the 72' auger with hydraulic lift, the lower connecting band has to be placed at an angle with the clamp connecting flanges at the 11:00 or 1:00 clock position instead of the normal 9:00 or 3:00 positions. This is so the clamp will not interfere with the center truss installation.

NOTE

If your auger IS NOT equipped with the optional INTERNAL BEARINGS, stop and go to step 5. If it IS equipped with the optional INTERNAL BEARINGS, continue with step 4.

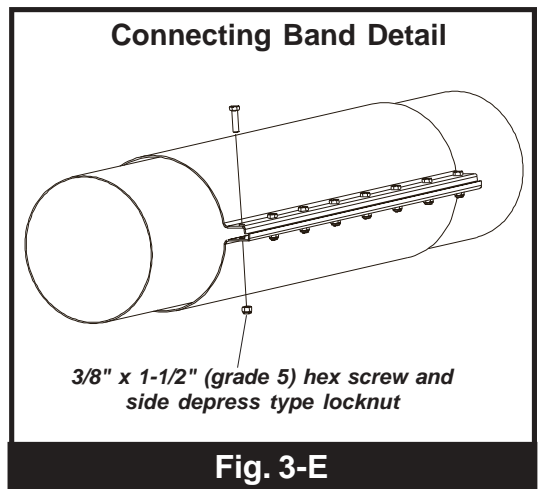

Fig. 3-E

4. Flight and Housing Assembly for Augers with Optional Internal Flight Bearings (42', 52', 62', and 72' Augers)

- A. The connecting band should be placed onto the lower end of the head (or Upper Middle for 72') auger section. Do NOT tighten bolts yet.
- B. The internal bearing hanger should be placed over the end of the flight connecting stub on the middle auger section. Next, slide the flight section out of the head or upper middle auger housing section. Connect the middle and head flight sections together. Use two (2) 7/16" x 3" long (grade 8) hex head capscrews and stover type locknuts. (See Fig. 4-A.)
- C. Slide the auger housing sections together so the tube ends are butted against each other to make a tight seam. Position the connecting band so it covers both housing sections equally. This should put the seam of the auger housings in the middle of the connecting band. Tighten the connecting band down by using six (6) 3/8" x 1-1/2" long (grade 5) hex head capscrews and nylon locknuts. (See Fig. 3-E)

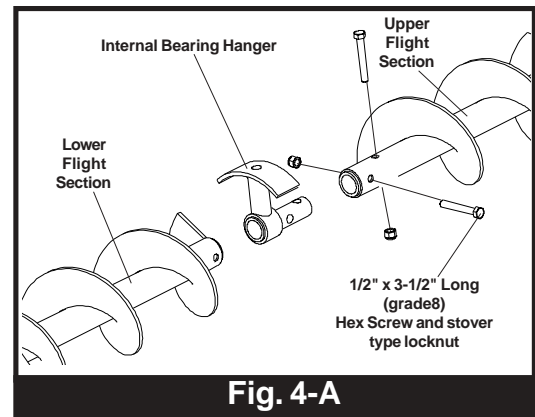

Fig. 4-A

4. Flight and Housing Assembly for Augers with Optional Internal Flight Bearings (42' - 62', & 72' Augers) cont.

D. Attach the internal bearing hangers to the auger housing.

1. Detach the bands that are over the bearing access area.
2. Grab the internal bearing hanger stem through the bearing access area and rotate the bearing until it lines up with the 3/4" hole on the top of the auger housing. (See Fig. 4-B)
3. Line up the holes in the bearing hanger and auger housing, and fasten them together using a 5/8" x 1-1/2" long (grade 5) hex head capscrew and lockwasher. Before tightening, be sure the bearing is centered between the ends of the auger flighting by looking through the bearing hanger access area.

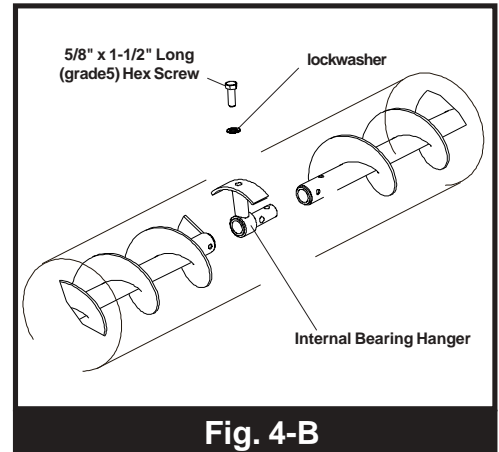

Fig. 4-B

5. Blow-Off End Cap

- A. Place one (1) 3/32" x 1-1/4" long cotter pins onto each end link of the chain. (See Cotter Pin Detail and Fig. 5)
- B. Insert one cotter pin with chain attached into the 1/8" hole at the end of the tube housing. Bend the legs of the cotter pin in opposite directions to secure the chain to the tube housing.
- C. Place the other cotter pin through the hole in the end cap and bend the legs of the cotter pin in opposite directions to secure the chain to the blow-off cap.
- D. Place the cap over the end of the tube housing. Affix the cap so it fits tight but will pop off if the discharge gets clogged. You should be able to tap the cap off by hand.

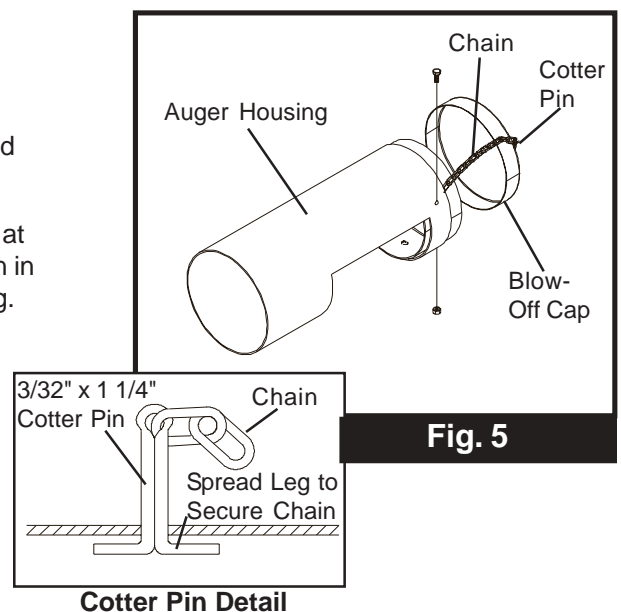

Fig. 5

6. Install the Intake Assembly

Two Types

NOTE

If using Intake GK3144 insert the intake guard half-bands prior to installation.

- A. Attach the intake guard to the auger housing. (See Fig. 6.)
- B. While sliding the intake guard on the auger housing, guide the intake stub shaft into the bushing.
- C. Secure the intake guard to the auger housing with plain half-band(s). Use 5/16" x 1-3/4" bolts, flatwashers, and nylon lock nuts.

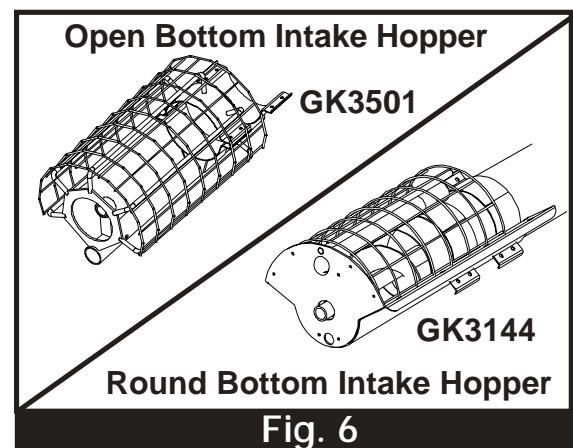

Fig. 6

NOTE

The upper half-band, for mounting the intake guard assembly, should be positioned to the discharge side of the 3/8" key welded to the auger housing.

NOTE

Do NOT slide the intake guard on so far that the auger flight is in contact with the intake bushing. Leave 3/8"-1/2" clearance.

7. Track and Truss Layout

A. Winch Lift Models Only

⚠ WARNING

The location of components that band to the auger tube is critical for proper operation of the undercarriage system. **DO NOT MODIFY OR SUBSTITUTE OTHER COMPONENTS IN AN EFFORT TO COMPLETE THE ASSEMBLY OF THE AUGER.** If the auger components you have **DO NOT** match the lengths specified in these instructions or you **CANNOT** position the components where instructions specify due to interference with other items mounted on the auger tube, contact your dealer or the factory immediately.

⚠ WARNING

Property damage, personal injury, and/or death will result if you fail to locate components in the proper location. Failure to locate these components will cause the undercarriage to fail and the auger to fall.

32' AUGER

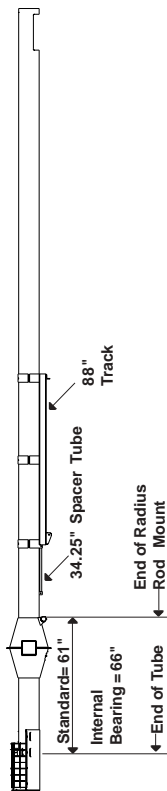

37' AUGER

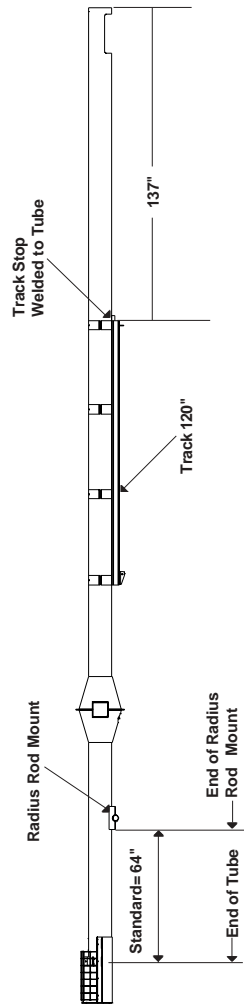

42' AUGER

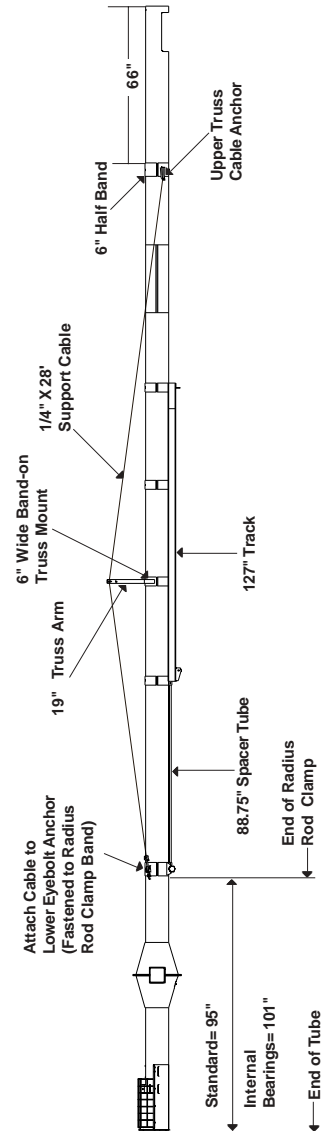

7. Track and Truss Layout (cont'd)
A. Winch Lift Models Only (cont'd)

52' AUGER

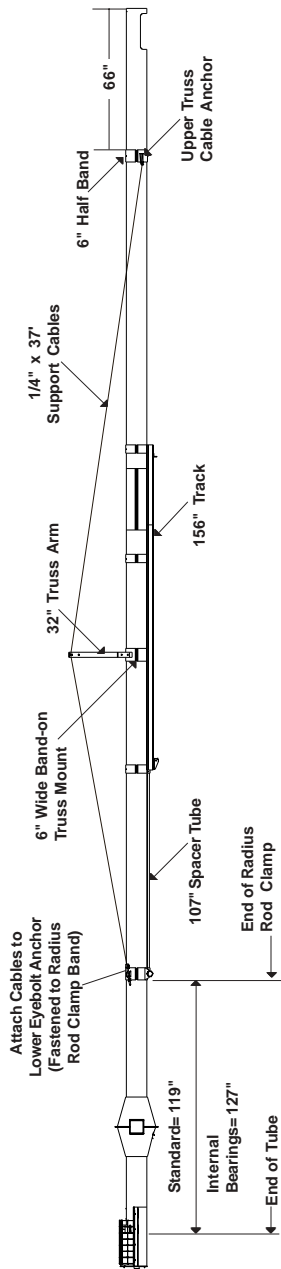

62' AUGER

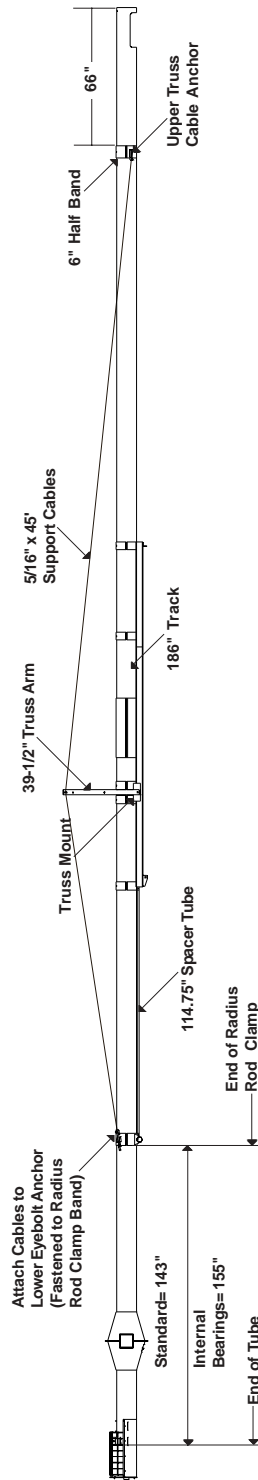

72' AUGER

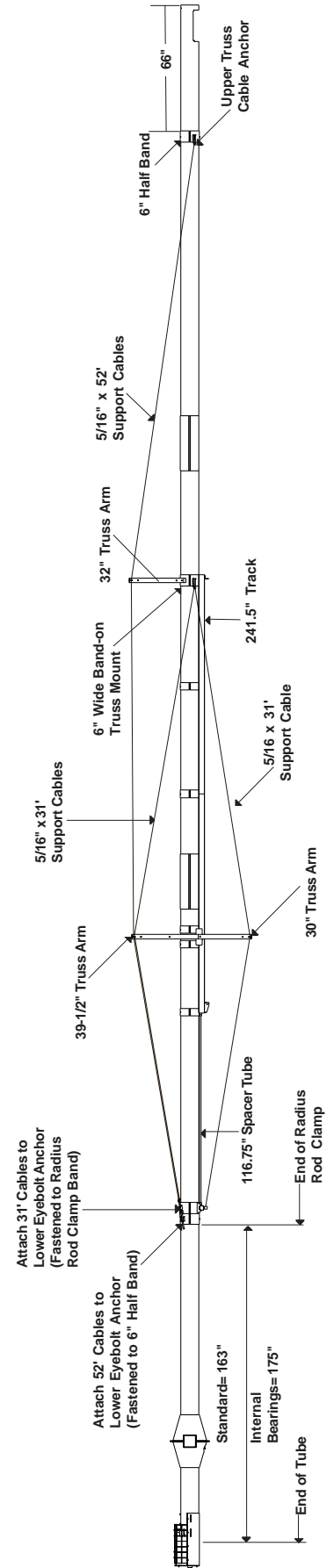

8. Assemble the Radius Rod Clamp.

NOTE

The 32' and 37' do not use a radius rod clamp band or a spacer tube. The 37' track stops are mounted to the tube housing.

- A. To attach the track and position the radius rod clamp band(s), measure from the intake end of the tube to the corresponding measurement(s) for your size model on pages 16-17. Fasten the radius rod clamp band to the auger using a heavy duty half-band and six (6) 3/8" x 1-1/2" long hex head capscrews and nylon locknuts. **On 42', 52', 62' and 72'** augers the heavy duty half-band will have eyebolt anchors welded to it. The eyebolt anchor ends **MUST** point toward the discharge end of the auger. (See Fig. 8)
- B. Attach upper truss cable anchor to tube using (6) 3/8" x 1-1/2" (grade 5) hexhead capscrews and nylon locknuts. Make sure the anchor loop is pointed towards the intake end. (See Fig. 8-A)

9. Installing the Spacer Tube

- A. Insert the spacer tube into the collar on the radius rod clamp band (*for the 32' the receiver is welded to the tube*). Secure the lower spacer tube end to the radius rod clamp using a 5/16" x 1-3/4" hex head capscrew and nylon locknut.

10. Installing the Track.

- A. Position the track under the tube housing close to the position indicated in the drawings on page 16-17 for your size auger. Loosely attach track to tube by bolting the half-bands to the track using six (6) 3/8" x 1-1/2" (grade 5) hex head capscrews and nylon locknuts. Make sure the track can slide freely along the tube for final positioning.
- B. Slide the track towards the spacer tube until the spacer tube is seated into the receiver on the track. Fasten the spacer tube to the track using 5/16" x 1-3/4" bolt and nylon locknut.
- C. **Make sure the spacer tube and track are aligned down the center along the bottom side of the tube housing.** Go back and tighten the 3/8" x 1-1/2" bolts on the half-bands.

11. Truss Assembly for Manual Lift Undercarriage

A. 42' Truss Assembly (See Fig. 11-A)

1. Attach the right side truss arm to the right side of the truss mounting band using a 1/2" x 1-1/2" (grade 5) hex head bolt and nylon locknut. **TIGHTEN BOLTS ONLY FINGER TIGHT AT THIS TIME.**
2. Attach the left side truss arm to the left side of the truss mounting band using a 1/2" x 1-1/2" (grade 5) hex head bolt and nylon locknut. **TIGHTEN BOLTS ONLY FINGER TIGHT AT THIS TIME.**
3. Fasten the truss crossbrace in between the right and left side truss arms using two (2) 3/8 x 1-1/4" (grade 5) hex head bolts and nylon lock nuts.
4. Go back and tighten all bolts and nuts on the truss mount.

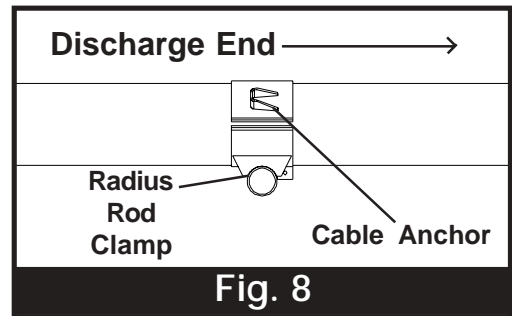

Fig. 8

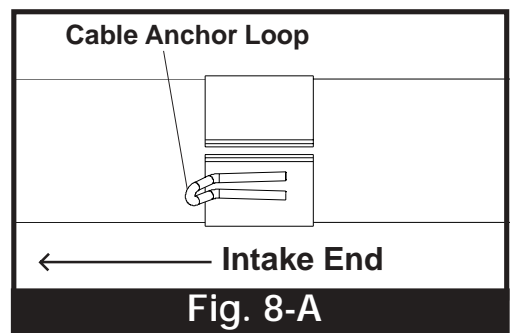

Fig. 8-A

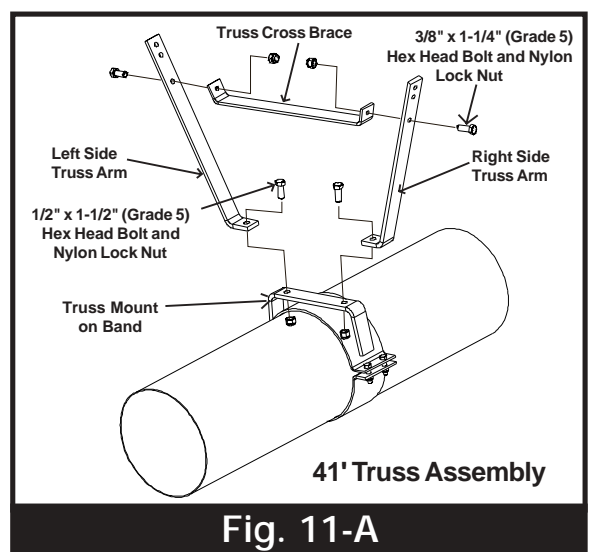

Fig. 11-A

11. Truss Assembly for Manual Lift Undercarriage (cont.)

B. 52' Truss and 72' Upper Truss Assemblies. (See Fig. 11-B)

1. Attach right and left side truss arms to the left and right side of the truss mounting band using four (4) 1/2" x 1-1/2" (grade 5) hex head bolts and nylon locknuts. **TIGHTEN BOLTS ONLY FINGER TIGHT AT THIS TIME.**
2. Fasten the truss crossbrace to the left and right side truss arms using two (2) 3/8" x 1-1/4" (grade 5) hex head bolts and nylon locknuts.
3. Go back and tighten all bolts and nuts on the truss mount.

C. 62' Truss Assembly (See Fig. 11-C)

1. Attach right and left truss arms to the right and left sides of the track using two (2) 5/8" x 1-1/2" hex head bolts (grade 5) with nylon locknut. **TIGHTEN ONLY FINGER TIGHT AT THIS TIME.**
2. Fasten lower and upper truss cross braces in between the right and left side truss arms using four (4) 3/8" x 1-1/4" (grade 5) hex head bolts and nylon locknuts.
3. Go back and tighten all bolts and nuts on the truss mount.

D. 72' Lower Truss Assembly for Winch Mount (See Fig. 11-D)

1. Attach the bottom 39-1/2" and top 30" truss side arms to the truss mount on the track using one 5/8" x 2" (grade 5) hex head bolt capscrew and nylon locknut per side. **TIGHTEN BOLTS ONLY FINGER TIGHT AT THIS TIME.** (Make sure the 39-1/2" Arms are installed between the truss mount and the 30" Arms.)
2. Fasten the lower truss crossbrace to the inside of the two 39-1/2" truss arms using two (2) 3/8" x 1-1/2" hex head bolt and nylon locknuts.
3. Attach the upper truss crossbrace to the inside of the two 39-1/2" truss arms and attach the vertical truss tubes to the outside of the 39-1/2" truss arms using the same two (2) 3/8" x 1-1/2" hex head bolt and nylon locknuts.
4. Attach the other end of the vertical truss tubes to the bottom of the 30" long truss arms using two (2) 3/8" x 1-1/4" hex head bolt and nylon locknuts.
5. Go back and tighten all bolts and nuts on the truss.

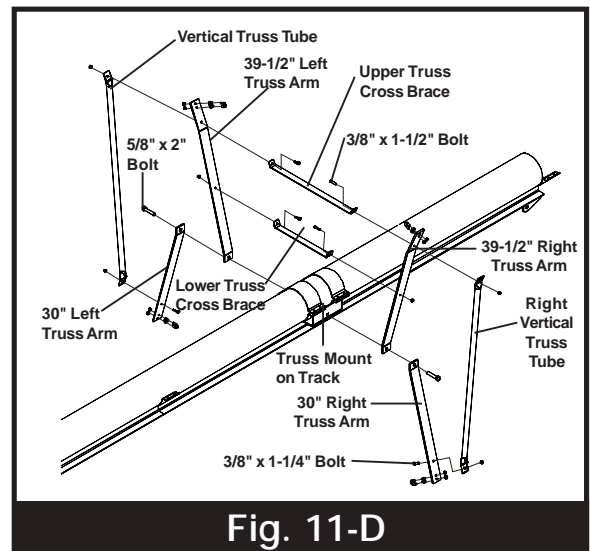
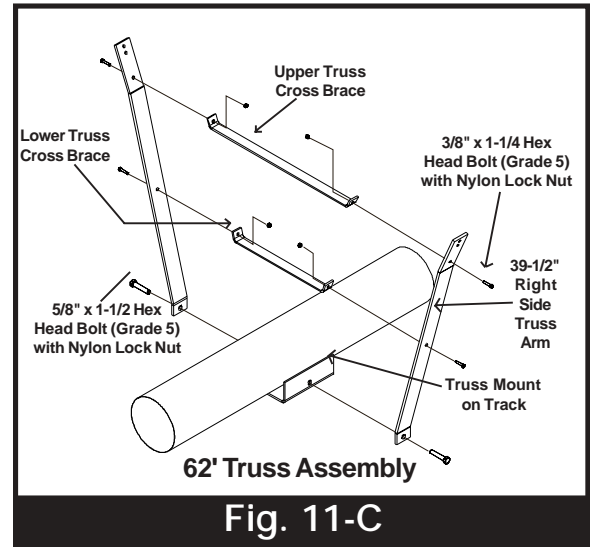
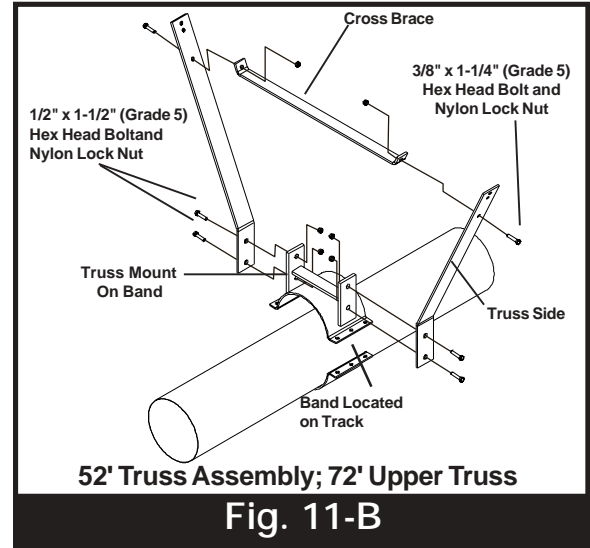

12. Truss Cable Assembly

NOTE 32' and 37' augers have no cables. 42'-62' have one set of truss cables. 72' has two sets of upper cables and one set of lower cables.

NOTE Secure the U-Bolts against the loose end of the cable, as shown in figure 12-A.

A. Truss Cable Assembly for 42', 52', and 62' Winch Augers

1. Start with the right side of the upper truss cable anchor (located near discharge end) that is welded to the 6" half band. Guide the end of one cable through the cable anchor and attach the loose end of the cable to itself using two (2) cable clamps. (See Fig. 12-A)
2. Run the cables to the top right side of the truss arm and fasten the cable to the truss using a 3/8" cable clamp. DO NOT fully tighten the cable clamps. The cable must be able to slide freely through the clamps when taking up the slack. (See Fig. 12-B.)
3. Run the cable down to the right lower eyebolt anchor located on the lower 6" half-band. Slide cable through the eyebolt and fasten loose end of cable using two cable clamps for each cable. (See Fig. 12-C.)
4. Repeat steps 1-3 with the left side support cable and using the left side anchors.
5. Screw eyebolts into left and right side eyebolt anchors to tighten cables and remove slack until snug. **TIGHTEN BOTH CABLES SO THEY HAVE THE SAME AMOUNT OF TENSION. DO NOT OVERTIGHTEN.**

NOTE The auger tube should have a slight upward bow when cables are tight.

6. Double check to be sure all sections are straight. Minor adjustments can be made after auger is assembled.
7. Go back and tighten 3/8" cable clamps on the truss arms.

NOTE Support the end of the auger tube while tightening truss cables.

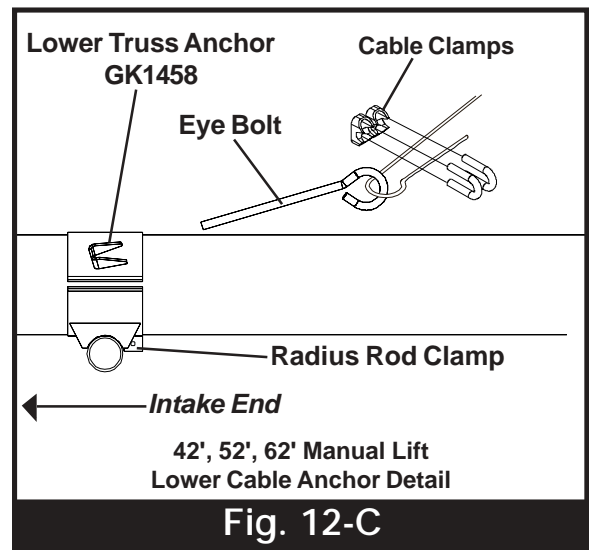
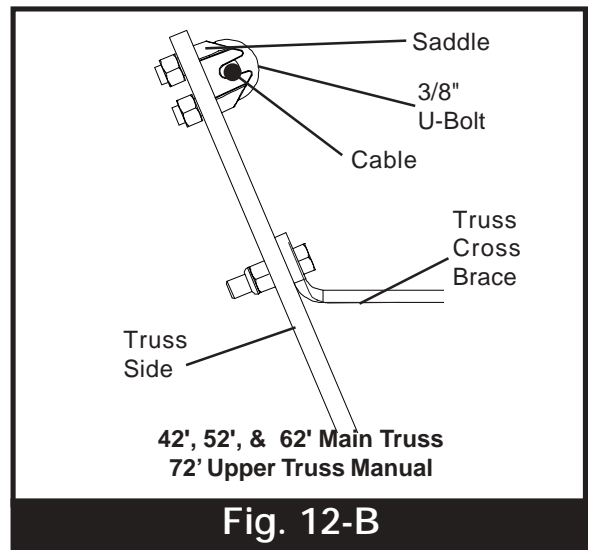
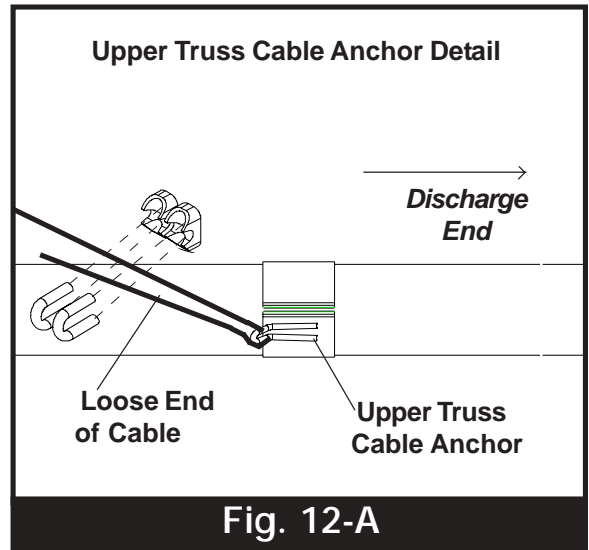

B. Truss Cable Assembly for 72' Winch Augers

Bottom Cable

1. Start at the two cable anchors located under the 32" truss arm, which are welded to the end of the track. Use one 31' cable per side and loop the cables through the anchors and tightly fasten the loose end of the cable to itself using two (2) 3/8" cable clamps per side. (See fig. 12-A.)
2. Run 31' cables to the right and left sides of 30" Truss arm located on the bottom side of the auger. Fasten cables to bottom 30" truss arms using (2) 3/8" cable clamps. **DO NOT TIGHTEN.** Cable must be allowed to slide freely until adjusted. (See Fig 12-D)
3. Run 31' cables up towards the Radius Rod Clamp. Loop ends of cables through eyebolts and fasten using (4) 5/16" cable clamps, two clamps for each cable. Screw eyebolts into the eyebolt anchors that are located on the bottom of the Radius Rod Clamp. (See Fig. 12-E.)

Top Cables

4. Starting at the right side upper truss cable anchor located near the discharge end. Guide one end of the 52' support cable through the cable anchor and fasten the loose end of cable to itself using two (2) 5/16" cable clamps. (See Fig. 12-A.)
5. Run the cable to the top right side of the 32" truss arm and fasten the cable to the truss using a 3/8" cable clamp. **DO NOT** fully tighten the cable clamp. The cable must be able to slide freely through the clamp when taking up the slack.
6. Run the 52' cable down the auger to the top right side of the 39-1/2" truss arm.
7. Loop the end of the 31' cable through the right side truss cable anchor located under the 32" truss arm. Fasten cable with (2) 3/8" cable clamps.
8. Gather up both the 52' and 31' cables and run both cables through the 3/8" U-Bolt and fasten. **DO NOT** fully tighten the cable clamps. The cables must be able to slide freely through the clamp when taking up the slack. (See Fig. 12-F.)
9. Run the 52' cable down the auger towards the bottom 6" half band. Loop end of cable through an eyebolt and fasten using (2) 3/8" cable clamps. Screw eyebolt into the eyebolt anchor that is welded on the right side of the 6" half band. (See Fig. 12-E.)
10. Run the 31' cable down the auger to the lower truss anchor which is attached to the radius rod clamp band. Loop end of cables through eyebolt and fasten using (2) 3/8" cable clamps. Screw eyebolt into the eyebolt anchor that is located on the bottom right side of the Radius Rod Clamp. (See Fig. 12-D.)
11. Repeat steps 4-10 for the left side support cables using the left side cable anchors.
12. **USING THE EYEBOLT SCREWS, TIGHTEN ALL CABLES SO THEY HAVE THE SAME AMOUNT OF TENSION. DO NOT OVERTIGHTEN.**
13. Go back and tighten up all cable clamps and U-Bolts.

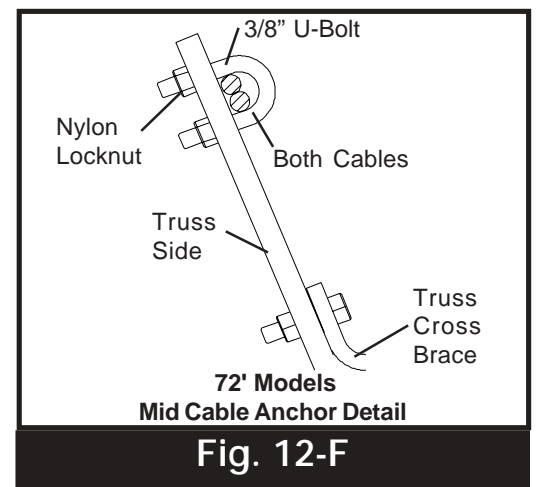
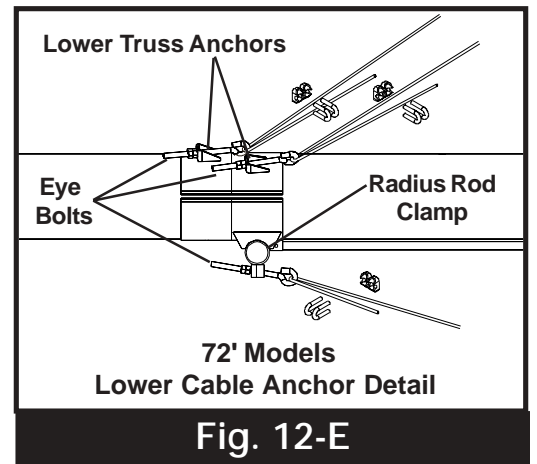
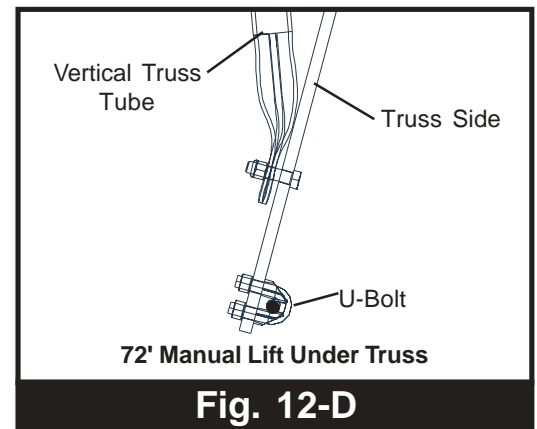

13. Manual Lift Assembly.

A. Discharge End Trolley Cable Pulley and Long Clevis

1. Place the pulley(s), washers, and spacer bushing to the short clevis as shown below and fasten them together using a 1/2" x 3" (grade 5) hex head capscrew making sure the capscrew is installed so the head is on the top side of the clevis when the clevis is assembled onto the auger. Insert the cotter pin into the small hole in the clevis and fasten to the clevis by bending the legs of the cotter pin apart.
2. Attach the long clevis to the track by fastening the trolley sides onto the track. (See Fig. 15-B)

NOTE

Use the locknuts and tighten so that the bushings will not turn against the clevis.
Torque to 80 ft/lbs.

Fig. 13-A - 32', 37', & 42' Augers

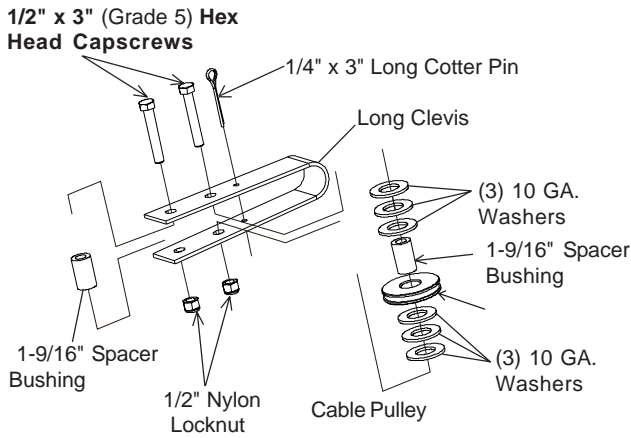
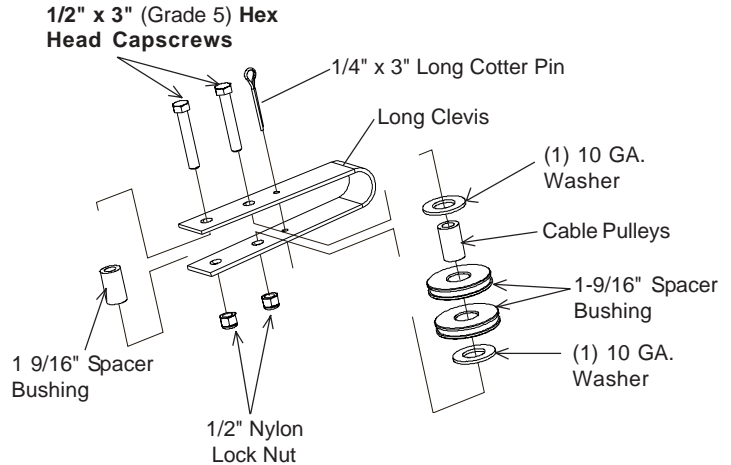

Fig. 13-B - 52', 62', & 72' Augers



B. Intake End Trolley Cable Pulley and Short Clevis

1. Place the pulley(s), washers, and spacer bushing to the long clevis as shown below. Fasten them together using 1/2" x 3" (grade 5) hex head capscrews making sure the capscrews are installed so the heads are on the top side of the clevis when the clevis is assembled onto the auger. Insert the cotter pin into the small hole in the clevis and fasten to the clevis by bending the legs of the cotter pin apart.
2. Attach the short clevis to the track by fastening the 5/8" x 4" bolt through the track and clevis.

Fig. 13-C - 32', 37', & 42' Augers

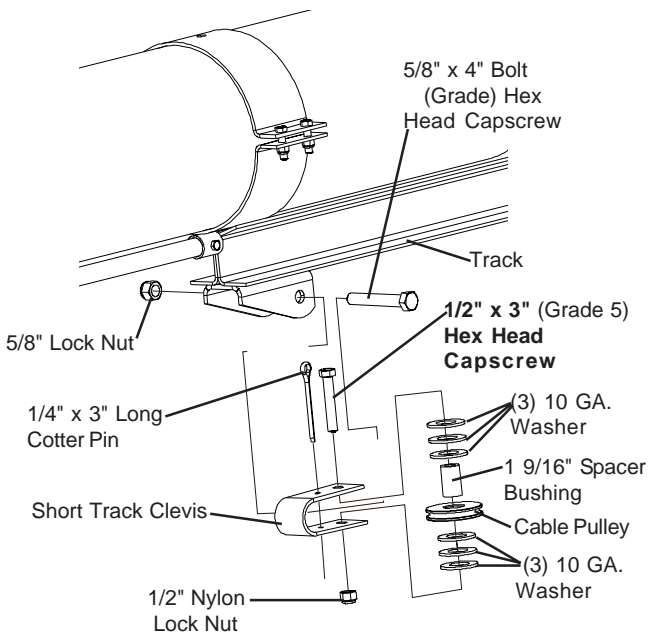
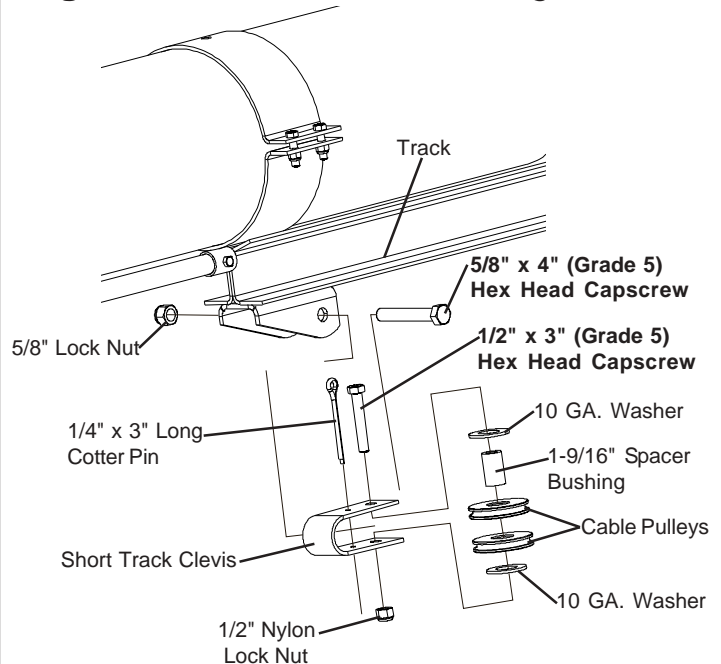

Fig. 13-D - 52', 62', & 72' Augers



14. Manual Lift Undercarriage Assembly.

- A. Place the left and right radius rod clamps close to positions shown in Fig. 14 below. The flattened ends of the radius rods must be facing towards the intake end of the auger. The left radius rod clamp with the winch mount MUST be on the left side, which is your left hand side when facing towards the intake end of the auger. Place undercarriage frame between the radius rods.
- B. Bolt the axle leg spacer tube to the bottom of the axle legs using a 7/16" x 2" (grade 5) hex head cap screw for 32' - 62' Augers and a 7/16" x 2-1/4" (grade 5) hex head cap screw on 72' models. Connect the short shafts on the axle legs into the square on the radius rods. Insert one 5/16" x 2" cotter pin in the end of each short shaft and bend back the legs of the pin to fasten.
- C. On 72' augers ONLY, connect axle leg crossbraces between the axle legs. Secure angles to ears on axle legs with four 1/2" x 1-1/4" long (grade 5) hex head capscrews and nylon locknuts. **DO NOT** fully tighten hardware until the trolley is assembled to the axle legs. Fasten the crossbraces through the middle with a 1/2" x 1" (grade 5) hex head capscrew and nylon locknut. **DO NOT** tighten hardware until later.

Fig. 14

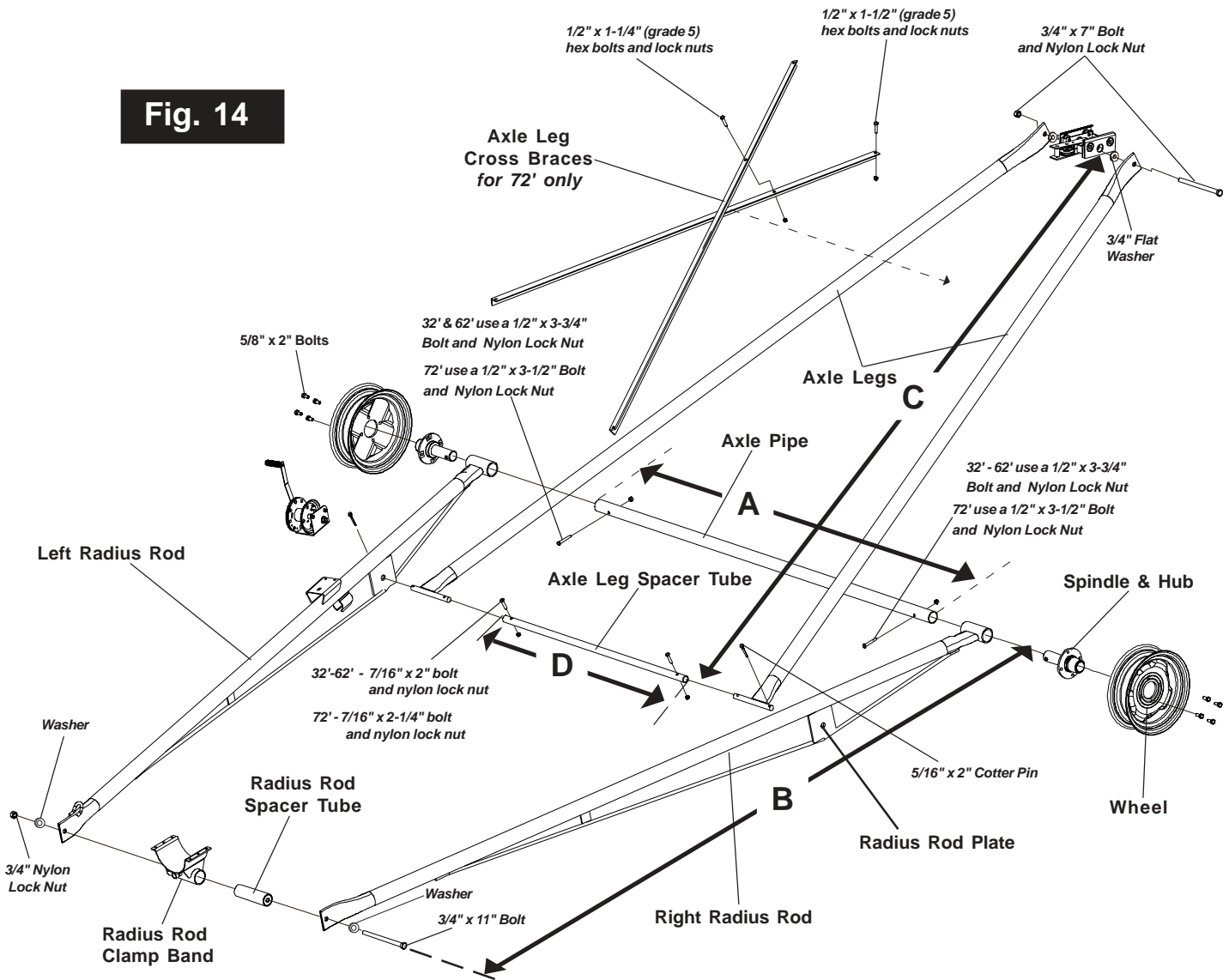

Manual Lift Models	32'	37"	42'	52'	62'	72'
"A" - Axle Spacer Tube Length	73"	94-1/2"	94-1/2"	94-1/2"	93"	120"
"B" - Radius Rod Length	77"	116"	116"	146"	176-3/4"	209-1/4"
"C" - Axle Leg Length	73-1/4"	126-1/2"	126-1/2"	152"	178"	193"
"D" - Axle Pipe Length	33"	53"	53"	51"	49-3/4"	72-1/2"

- D. Guide the axle shaft through the pipes on the ends of the short pipes at the end of the radius rods.
- E. Connect the spindle and hub radius rod clamp to the Axle Pipe as shown below and fasten together using two (2) hex head cap screws and nylon locknut. See bolt chart for spindle bolt sizes.

Auger Size	Bolt Size
32'	1/2" x 2-1/2" Long
42', 52'	1/2" x 3-1/4" Long
62', 72'	1/2" x 3-3/4" Long

- F. Fasten tire and rim to hub with lug four (4) lug nuts on each side.

⚠ DANGER

Before lowering the auger, make sure the intake is on the ground, and the trolley is touching the down stop. Check the transport height of the auger by measuring the distance from the top of the auger's discharge end to the ground. Check your measurement with the chart on page 42. If your measurement doesn't fit into the range on the chart for your size auger go back double check the following:

1. **Location of radius rod clamp and track.** (See page 16-17.)
2. **The length of the undercarriage components.** (See page 23.)
3. **The length of auger tubes.** (See page 11.)
4. **Is the discharge end of the auger tube sagging because the truss cables require tightening?** (See page 20-21.)

If you have double checked all of the above items and your measured discharged height is **NOT** in the range specified in the transport height chart on page 42, call your dealer or the factory immediately. **DO NOT CONTINUE TO ASSEMBLE THE AUGER** and do not release the hoist with the auger in this condition. Failure to do so could result in damage to the auger and/or serious injury to personnel.

- G. When the transport height is correct as described above, the lifting device may be released.

15. Manual Track & Tube Housing to Undercarriage

- A. Place strap or chain around the auger tube housing about 1/3 of the way down from the discharge end. Use a lifting device and lift the auger tube about approximately 6' from the ground. Roll the undercarriage into position under the tubing.
- B. Assemble trolley, spacer, and long clevis to track. (See Fig. 15-B)

NOTE

During installation, it may be helpful to hold the trolley in position using a c-clamp.

- C. Raise axle legs and bolt the trolley spacer with long clevis and pulley assembly together using a 3/4" x 7" long (grade 5) hex head capscrew, flat washers and nylon locknut. Make sure washers are placed between spacer bushing and axle legs. (See Fig. 15-B)
- D. Insert the radius rod spacer tube into the radius rod clamp band. Then, insert a 3/4" x 11" long (grade 5) hex head bolt through a flat washer, the right radius rod, and through the spacer tube to the left side. Then through the left radius rod, another flat washer and a nylon locknut. (See Fig. 15-D)
- E. Double check that all undercarriage bolts and fasteners are tight and assembled correctly. On 72' augers go back and tighten all the 1/2" hex head capscrews that fasten the angle crossbraces to axle legs.

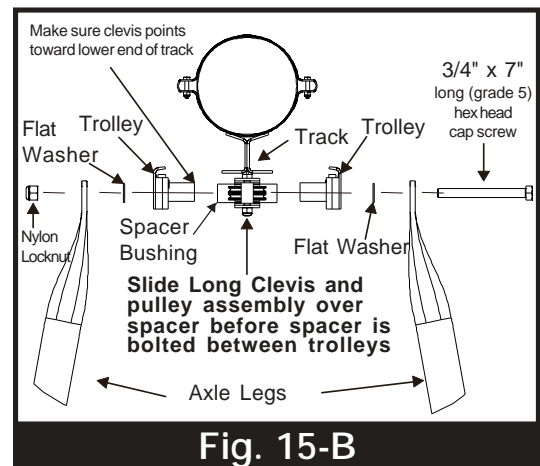

Fig. 15-B

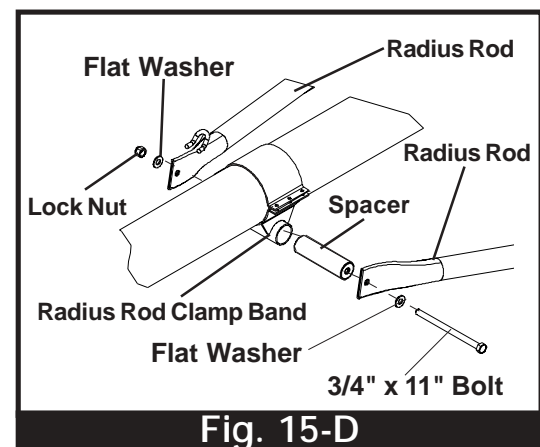

Fig. 15-D

⚠ WARNING

The trolley must be assembled to the track so it cannot slip off or be removed from the track.

16. Winch and Cable Assembly (Manual lift only)

A. Bottom Clevis Assembly

1. Hook clevis plates to the anchor on the left radius rod.
(See Fig. 16-A)
2. Assemble the two (2) washers, pulley, and bushing in between the clevis plates and fasten together using 1/2" x 2" hex head cap screw and nylon locknut.
3. Double check and make sure the clevis plates are secure and can't slip off.

CAUTION

Use locknut and tighten so bushing will not turn against clevis plates.

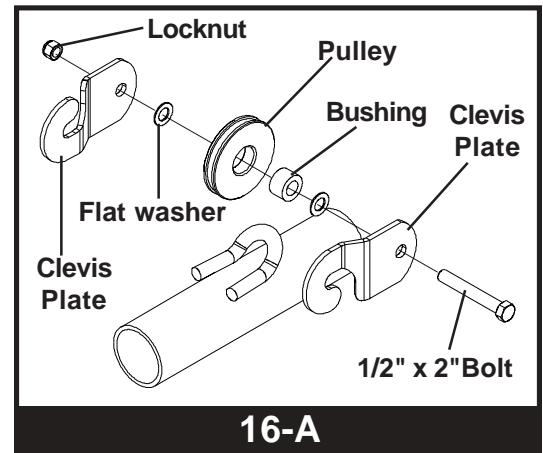

16-A

B. Winch

1. Assemble the winch. See instructions that are with the winch.
2. Bolt the winch assembly to the mount located on the left radius rod so the winch drum is towards the intake end of the auger.
Use three (3) 3/8" x 1" long (grade5) hex head bolts, flatwashers, and nylon locknuts to attach the winch to the mount.
(See Fig. 16-B.)
3. Tighten it with a wrench.

C. Cable

1. Connect the 1/4" lift cable to the winch drum so the cable will wrap **OVER** the winch drum on 32' - 62' size augers and **UNDER** the winch drum on the 72' size augers when turning the handle in a clockwise direction. (See Fig. 16-C.)
2. From inside of drum, insert the cable through one round hole in the drum side, until it extends 1" past the two square holes.
3. Clamp the cable to the outside of the drum with the cable keeper, using two (2) 3/16" x 3/4" carriage bolts, lock washers, and nuts. Be sure that the carriage bolt heads are on the inside of the drum.

CAUTION

The cable keeper alone will not hold the weight of the auger. There should be enough cable so that when the auger is all the way down there are at least 3 turns of cable on the winch drum. Never let the cable all the way out. Always keep a minimum of three (3) turns of cable on the winch drum. Cable should never be fully extended. If there are not (3) turns of cable around the winch drum when the auger is fully lowered, then the cable must be replaced with a longer cable.

Cable wraps over the drum on the 1000# & 1500# winch; Cable wraps under the drum for the 2500# winch.

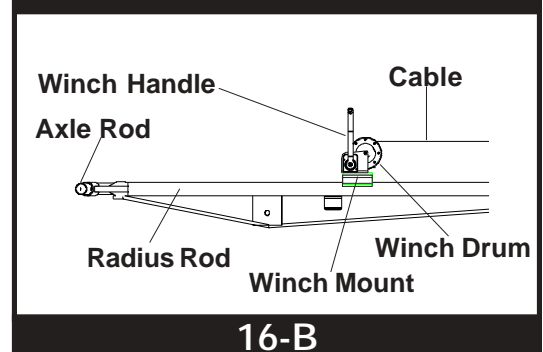

16-B

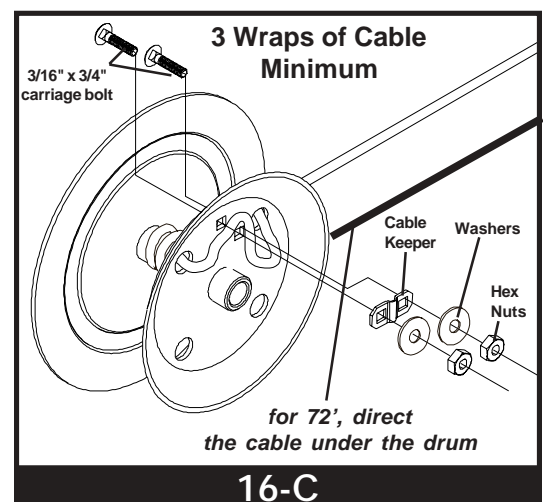

16-C

16. Winch and Cable Assembly. (Manual Lift only) (cont.)

C. Cable (cont.)

4. Assemble the lift cable from the winch through the pulleys and fasten the end to the trolley as shown below. For 32', 37', and 42' size augers use Fig. 16-D for cable path. For 52', 62', and 72' use Fig. 16-E for cable path.

CAUTION Secure the lift cable to the trolley with two (2) cable clamps, with the clamp U-Bolt against the loose end of the cable.

WARNING Make sure the cable is located on all cable pulleys BEFORE raising the auger using the winch. Do NOT disassemble pulley(s) from clevis(s) during rigging.

Fig. 16-D - Rigging for 32', 37', and 42' Models

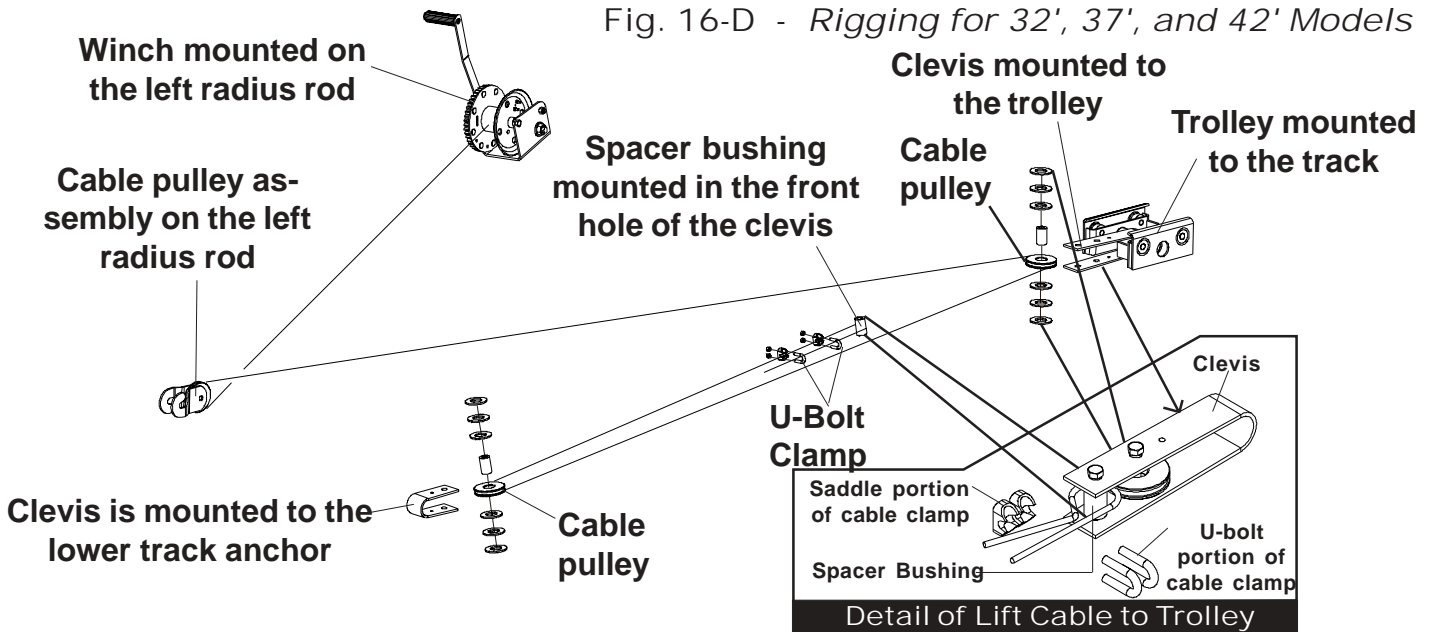
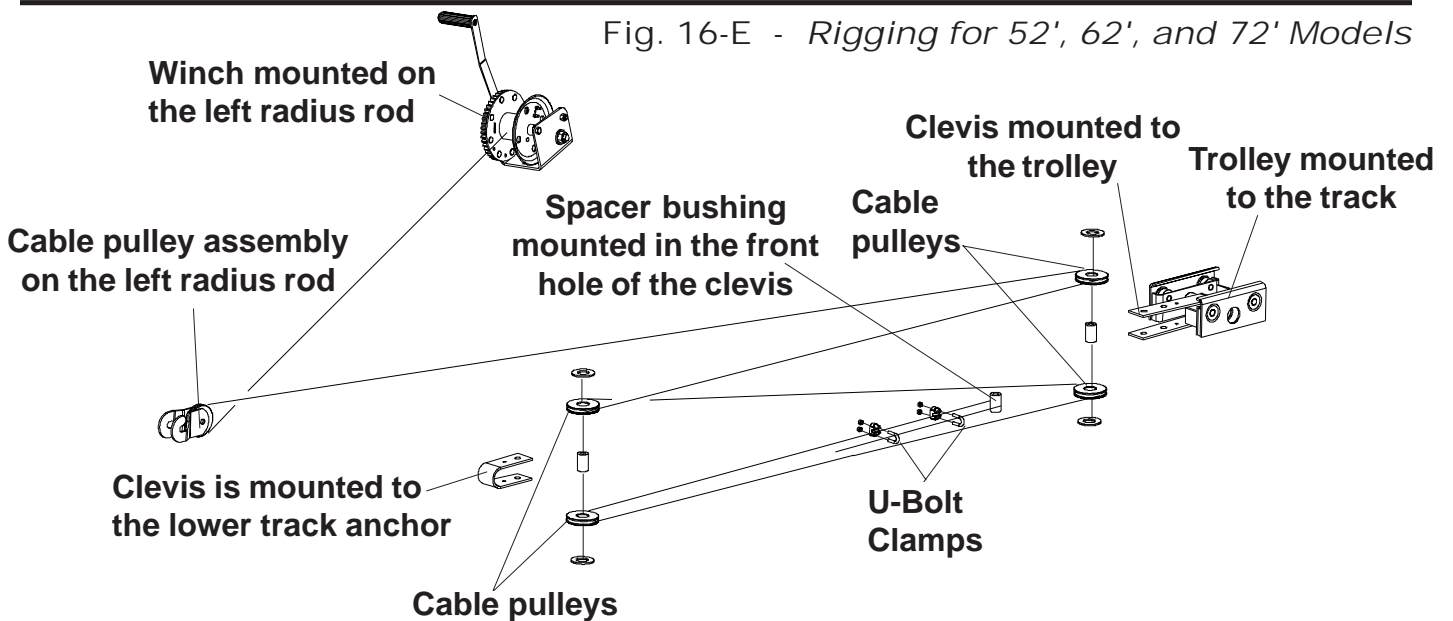

Fig. 16-E - Rigging for 52', 62', and 72' Models



NOTE Make sure that the cable is inserted over the top of the pulley and not the bottom.

17. Track and Truss Layout for Hydraulic Lift Undercarriage Models

52' AUGER

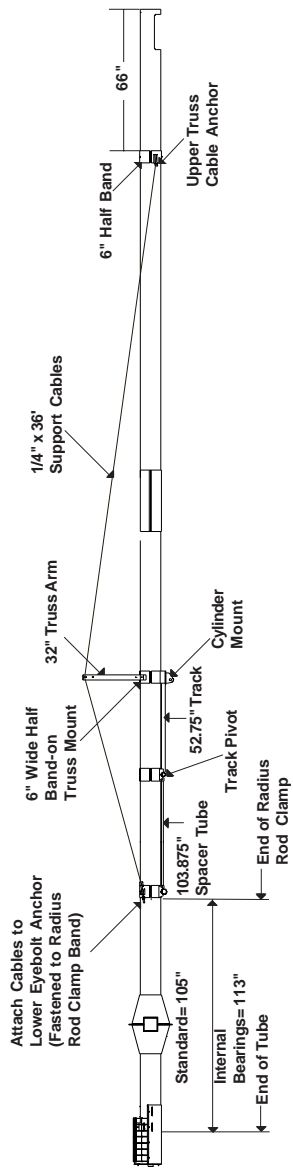

62' AUGER

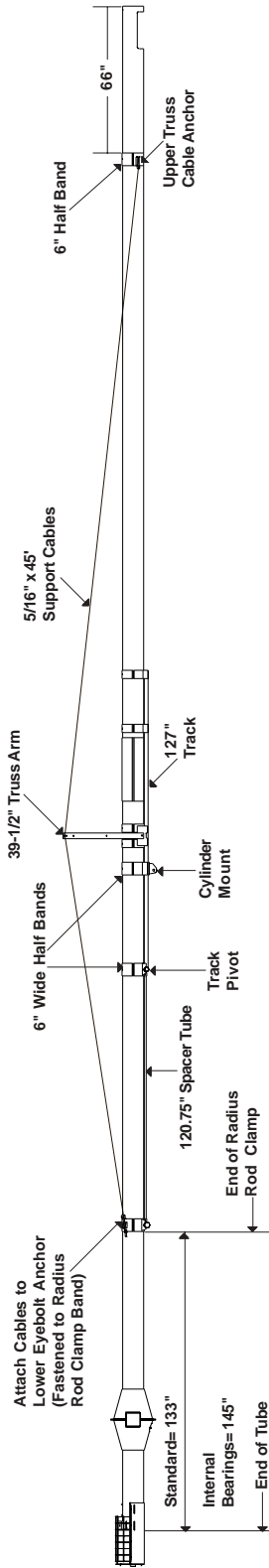

72' AUGER

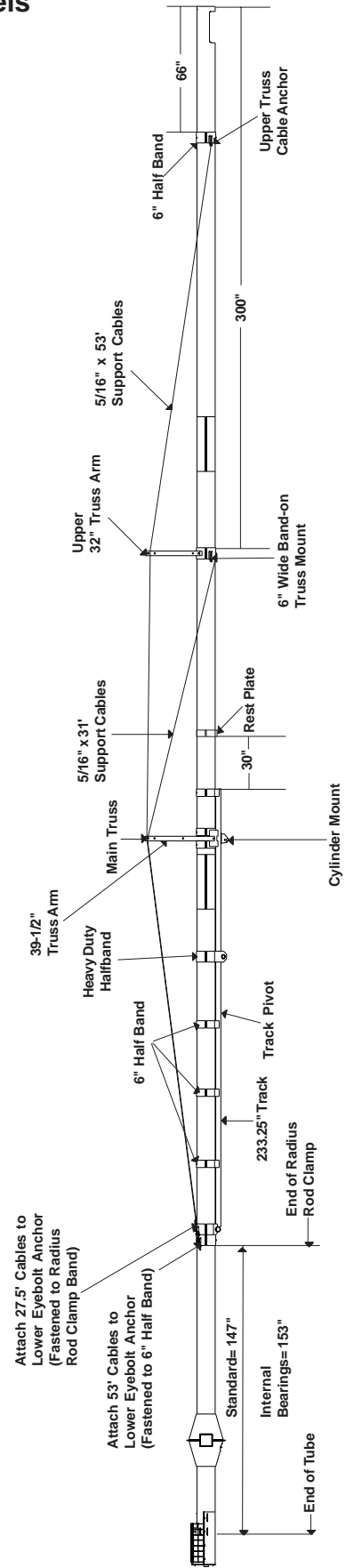

18. Assemble the Radius Rod Clamp.

NOTE

The 32' and 37' do not use a radius rod clamp band or a spacer tube. The 37' track stops are mounted to the tube housing.

- A. To attach the track and position the radius rod clamp band(s), measure from the intake end of the tube to the corresponding measurement(s) for your size model on pages 27. Fasten the radius rod clamp band to the auger using a heavy duty half-band and six (6) 3/8" x 1-1/2" long hex head capscrews and nylon locknuts. **On 42', 52', 62' and 72'** augers the heavy duty half-band will have eyebolt anchors welded to it. The eyebolt anchor ends **MUST** point toward the discharge end of the auger. (See Fig. 18)
- B. Attach upper truss cable anchor to tube using (6) 3/8" x 1-1/2" (grade 5) hexhead capscrews and nylon locknuts. Make sure the anchor loop is pointed towards the intake end. (See Fig. 18-B)

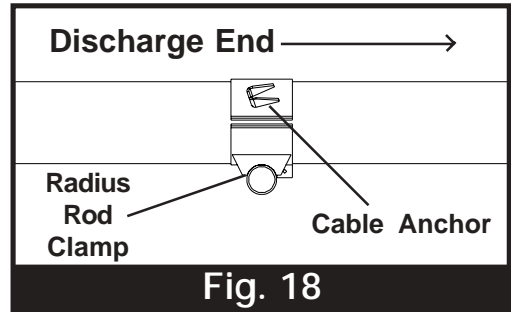

Fig. 18

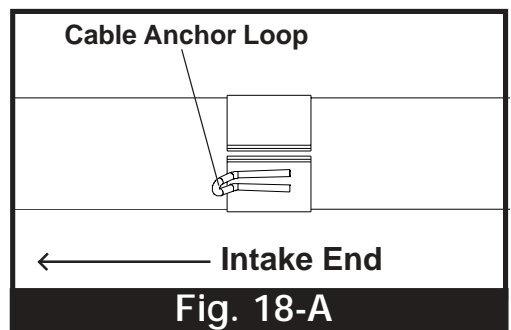

Fig. 18-A

WARNING

The location of components that band to the auger tube is critical for proper operation of the undercarriage system. If the auger components you have do not match the specified lengths in these instructions or you cannot position the components where instructions specify due to interference with other items mounted on the auger tube, contact your dealer or the factory immediately. **DO NOT** modify or substitute other components in an effort to complete the assembly of the auger.

19. Installing the Spacer Tube

- A. Insert the spacer tube into the collar on the radius rod clamp band (*for the 32' the receiver is welded to the tube*). Secure the lower spacer tube end to the radius rod clamp using a 5/16" x 1-3/4" hex head capscrew and nylon locknut.

20. Installing the Track.

- A. Position the track under the tube housing close to the position indicated in the drawings on page 27 for your size auger. Loosely attach track to tube by bolting the half-bands to the track using six (6) 3/8" x 1-1/2" (grade 5) hex head capscrews and nylon locknuts. Make sure the track can slide freely along the tube for final positioning.
- B. Slide the track towards the spacer tube until the spacer tube is seated into the receiver on the track. Fasten the spacer tube to the track using 5/16" x 1-3/4" bolt and nylon locknut.
- C. **Make sure the spacer tube and track are aligned down the center along the bottom side of the tube housing.** Go back and tighten the 3/8" x 1-1/2" bolts on the half-bands.

21. Truss Assembly for Hydraulic Lift Undercarriage

A. 52' Main Truss and 72' Upper Truss Assembly (See Fig. 21-A)

1. Attach right and left side truss arms to the left and right side of the truss mounting band using four (4) 1/2" x 1-1/2" (grade 5) hex head capscrews and nylon locknuts. **TIGHTEN BOLTS ONLY FINGER TIGHT AT THIS TIME.**
2. Fasten the truss crossbrace to the left and right side truss arms using two (2) 3/8" x 1-1/4" (grade 5) hex head capscrews and nylon locknuts.
3. Go back and tighten all bolts and nuts on the truss mount.

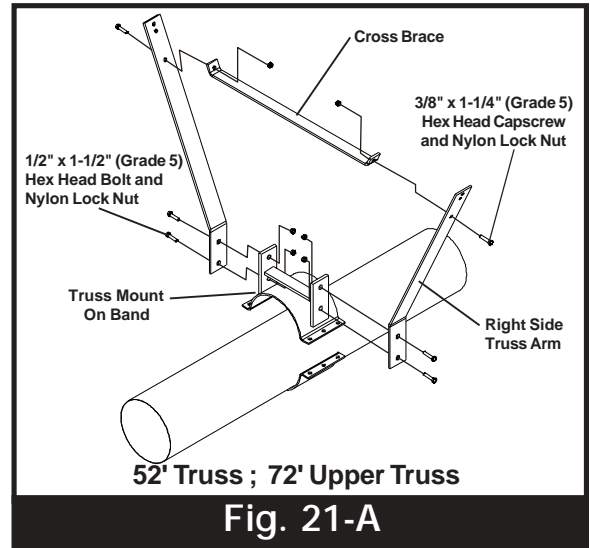

Fig. 21-A

C. 62' Truss Assembly (See Fig. 21-B)

1. Attach right and left truss arms to the right and left sides of the track using two (2) 5/8" x 1-1/2" hex head bolts (grade 5) with nylon locknut. **TIGHTEN ONLY FINGER TIGHT AT THIS TIME.**
2. Fasten lower and upper truss cross braces in between the right and left side truss arms using four (4) 3/8" x 1-1/4" (grade 5) hex head bolts and nylon locknuts.
3. Go back and tighten all bolts and nuts on the truss

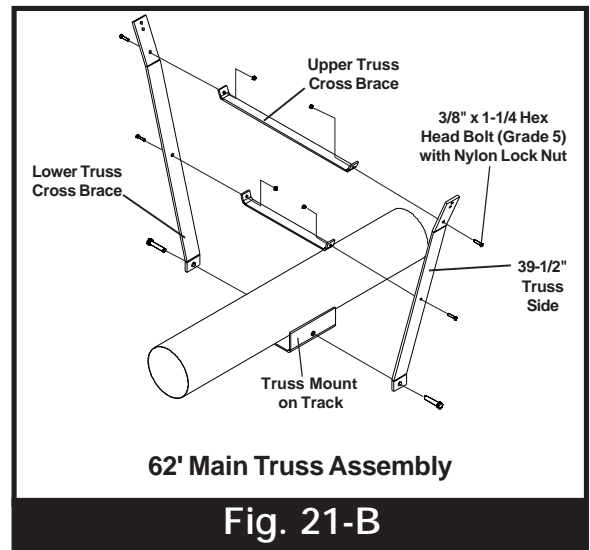

Fig. 21-B

NOTE

Secure the U-Bolts against the loose end of the cable, as shown in figure 23-A.

22. Cable Assembly for 52' and 62' Augers with Hydraulic Lift Undercarriage

1. Start with the right side of the upper truss cable anchor (located near discharge end) that is welded to the 6" half band. Guide the end of one cable through the cable anchor and attach the loose end of the cable to itself using two (2) sets of cable clamps. (See Fig. 22-A)
2. Run the cables to the top right side of the truss arm and fasten the cable to the truss using a 3/8" cable clamp. **DO NOT** fully tighten the cable clamps. The cable must be able to slide freely through the clamps when taking up the slack. (See Fig. 22-B.)

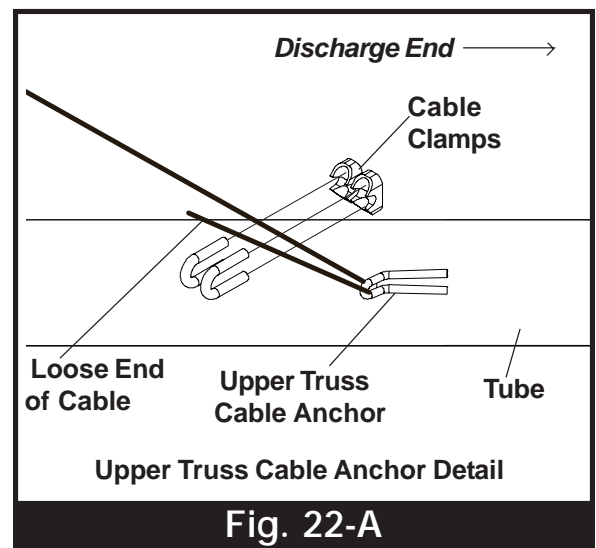

Fig. 22-A

22. Cable Assembly for 52' and 62' Augers with Hydraulic Lift Undercarriage (Cont.)

3. Run the cable down to the right lower eyebolt anchor located on the lower 6" half-band. Slide cable through the eyebolt and fasten loose end of cable using two cable clamps for each cable. (See Fig. 22-C.)
4. Repeat steps 1-3 with the left side support cable and using the left side anchors.
5. Screw eyebolts into left and right side eyebolt anchors to tighten cables and remove slack until snug. **TIGHTEN BOTH CABLES SO THEY HAVE THE SAME AMOUNT OF TENSION. DO NOT OVERTIGHTEN.**
6. Double check to be sure all sections are straight. Minor adjustments can be made after auger is assembled.
7. Go back and tighten cable clamps on the truss arms.

NOTE Support the end of the auger tube while tightening truss cables.

NOTE The auger tube should have a slight upward bow when cables are tight.

23. Cable Assembly for 72' Augers with Hydraulic Lift Undercarriage (Cont.)

1. Starting with the right side upper truss cable anchor that is welded to the 6" half band located, near the discharge end, guide one end of the 52' support cable through the cable anchor and fasten the loose end of cable to itself using two (2) 5/16" cable clamps. (See Fig. 22-A on page 29)
2. Run the cable to the top right side of the 32" truss arm and fasten the cable to the truss using a 3/8" cable clamp. **DO NOT** fully tighten the cable clamps. The cable must be able to slide freely through the clamps when taking up the slack.
3. Run the 52' cable down the auger to the top right side of the 39-1/2" truss arm.
4. Loop the end of the 31' cable through the right side truss cable anchor located under the 32" truss arm. Fasten cable with (2) 5/16" cable clamps.

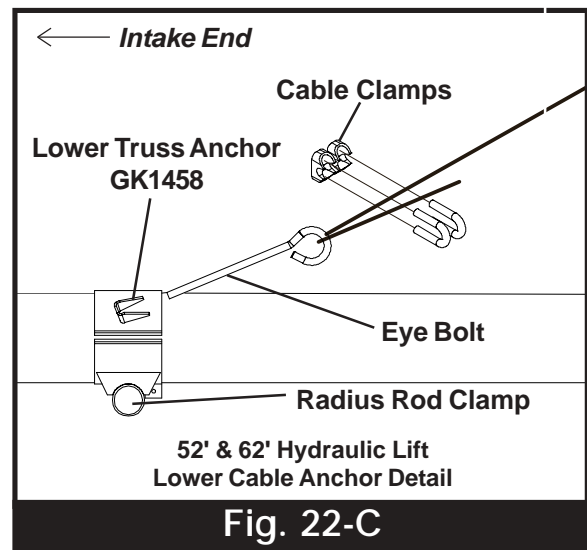
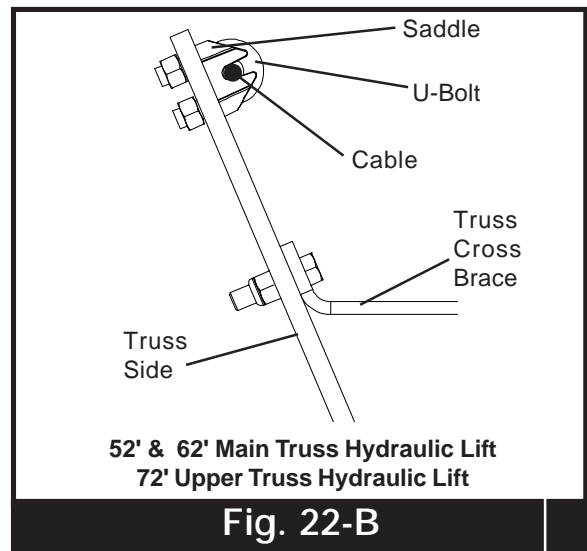

5. Gather up both the 52' and 31' cables and run both cables through the 3/8" U-Bolt and fasten. DO NOT fully tighten the cable clamps. The cables must be able to slide freely through the clamp when taking up the slack. (See Fig. 23-A)
6. Run the 52' cable down the auger towards the bottom 6" half band. Loop end of cable through an eyebolt and fasten using (2) 5/16" cable clamps. Screw eyebolt into the eyebolt anchor that is welded on the right side of the 6" half band. (See Fig. 23-B)
7. Run the 31' cable down the auger to the Radius Rod Clamp. Loop end of cables through eyebolt and fasten using (2) 5/16" cable clamps. Screw eyebolt into the eyebolt anchor that is located on the bottom right side of the Radius Rod Clamp. (See Fig. 23-B)
8. Repeat steps 4-10 for the left side support cable using the left side cable anchors.
9. USING THE EYEBOLT SCREWS, TIGHTEN ALL CABLES SO THEY HAVE THE SAME AMOUNT OF TENSION. DO NOT OVERTIGHTEN.
10. Go back and tighten up all cable clamps and U-Bolts.

NOTE

The auger tube should have a slight upward bow when cables are tight.

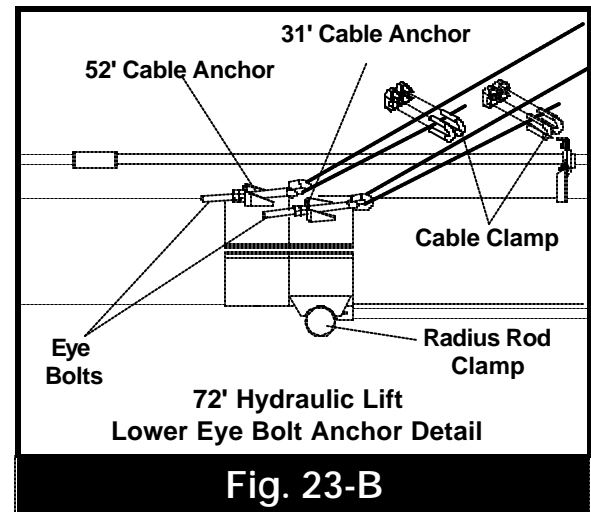
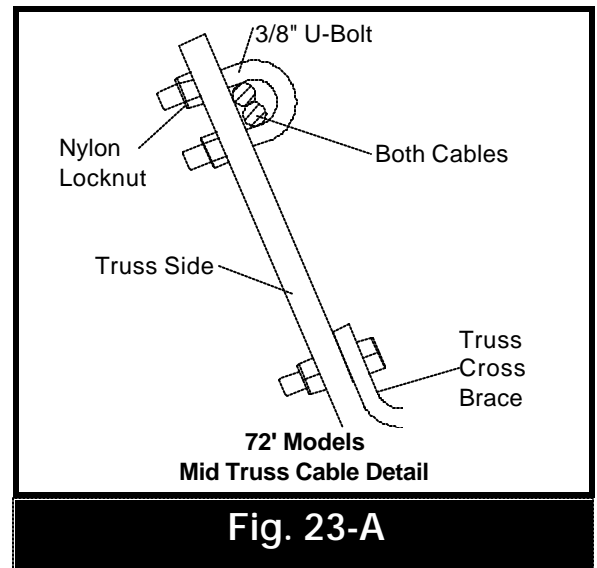

24. Hydraulic Undercarriage Assembly

- Place the left and right radius rod clamps close to positions shown in Fig. 24 below. The flattened ends of the radius rods must be facing towards the intake end of the auger. The left radius rod clamp with the winch mount **MUST** be on the left side, which is your left hand side when facing the discharge end. Place undercarriage frame between the radius rods.
- Insert the pivot shaft into the square plates on the radius rods. Secure using one 5/16" x 2" cotter pin for each pivot shaft.
- Guide the axle shaft through the short pipes at the end of the radius rods. Slide the hub and spindle assembly into the undercarriage axle and fasten using a hex head capscrew and nylon locknut. For 52' augers use two (2) 12" x 3-1/4" long (grade 5) hex head capscrews. For the 62' and 72' augers use two (2) 1 1/2" x 3-3/4" long (grade 5) hex head capscrews.
- Fasten tire and rim to hub with lug four (4) lug nuts on each side.

Fig. 24

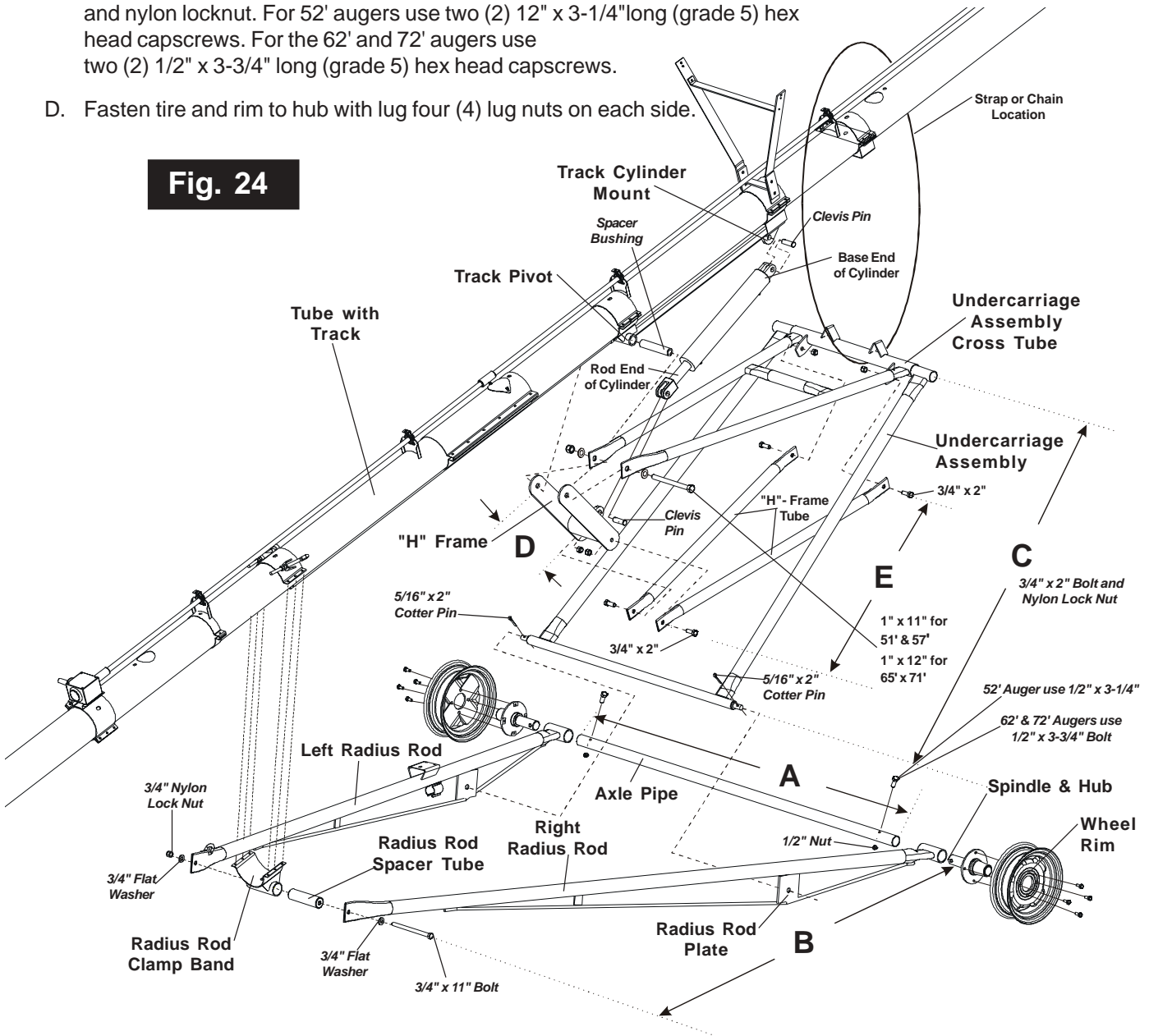

Hydraulic Lift Models	52'	62'	72'
"A" - Axle Spacer Tube Length	94-1/2"	93"	120"
"B" - Radius Rod Length	146"	176-3/4"	209-1/4"
"C" - Undercarriage Frame	88-1/8"	102-3/4"	115"
"D" - H-Frame (Center to Center of Holes)	19-1/4"	19-1/4"	26-5/8"
"E" - H-Frame Tubes (Overall Length)	64-1/2"	82-1/2"	97"
"F" - Cylinder Size	4" Bore x 24" Stroke	4" Bore x 24" Stroke	4" Bore x 36" Stroke

24. Hydraulic Undercarriage Assembly (Cont.)

- E. Place strap or chain around the auger tube housing about 1/3 of the way down from the discharge end. Use a lifting device and lift the auger tube about approximately 6' from the ground. Roll the undercarriage into position under the tubing. (See Fig 24 on pg 32)
- F. Insert the pivot spacer tube into the track pivot tube welded to the bottom of the track at the discharge end.
- G. Raise the upper undercarriage frame legs fasten the H-Frame and upper legs through the track pivot tube using a 1" x 11" (grade 5) hex head cap screw and nylon locknut on 52' & 62' augers or a 1" x 12" (grade 5) hex head capscrew and nylon locknut on 72' augers. (See Fig. 24-G)
- H. Fasten the "H" frame tubes to the lower end of the "H" frame with 3/4" x 2" long (grade 5) hex head capscrew and nylon locknut.

NOTE

Turn H-frame so cylinder mounting ear points toward the auger discharge end.

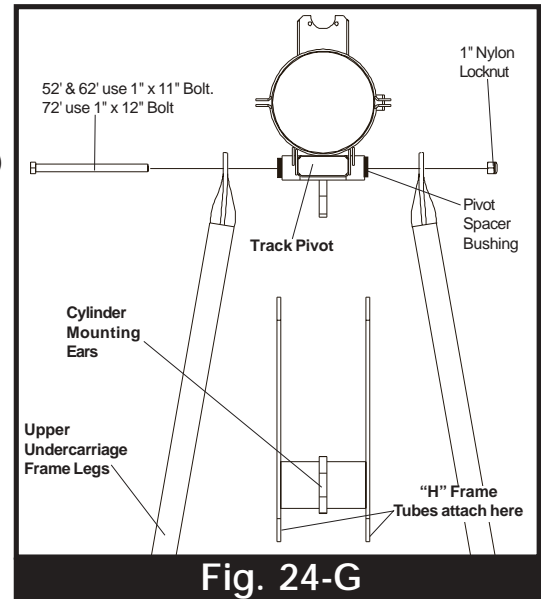

Fig. 24-G

- I. Fasten the other end of the "H" Frame tubes to the ears on the undercarriage crosstube with two (2) 3/4" x 2" long (grade 5) hex head capscrews and nylon locknuts.
- J. Wrap a chain or heavy duty strap around the auger tube and undercarriage frame chain or strap must be tight to keep the undercarriage from opening when the tube is raised to attach the radius rods to the radius rod clamp.
- K. Insert the radius rod spacer tube into the radius rod clamp band. Then, insert a 3/4" x 11" long (grade 5) hex head capscrew through a flat washer, the right radius rod, and through the spacer tube to the left side. Then through the left radius rod, another flat washer and a nylon locknut.
- L. Double check that all undercarriage bolts and fasteners are tight and assembled correctly.

⚠ DANGER

Before releasing the lift. Make sure the intake is on the ground, and the trolley is touching the down stop. Check the transport height of the auger by measuring the distance from the top of the auger's discharge end to the ground. Double check your measurement with the chart on page 44. If they don't fit into the range on the chart for your size auger go back double check the following!

1. **Location of radius rod clamp and track.** (See page 27.)
2. **The length of the undercarriage components.** (See page 32.)
3. **The length of auger tubes.** (See page 11.)
4. **Is the discharge end of the auger tube sagging because the truss cables require tightening?** (See page 29-31.)

If you have double checked all of the above items and your measured discharged height is **NOT** in the range specified in the transport height chart on page 44, call your dealer or the factory immediately. **DO NOT CONTINUE TO ASSEMBLE THE AUGER** and do not release the hoist with the auger in this condition.

- M. When the transport height is correct as described above, the lifting device may be released.
- N. Attach the hydraulic cylinder to the cylinder mounting ears on the "H" frame using mounting pin and keeper clip that is furnished with the cylinder. (See Fig. 24-G)

NOTE

Flat washers go on before the spacer tube and radius rod.

CAUTION

The base of the cylinder must be attached to the mount on the track. The rod end of the cylinder will be attached to the cylinder mounting ears on the "H" frame. The cylinder ports must be facing the left side of the auger when viewing the auger from the intake end.

The cylinder furnished with your auger has a restrictor in the port at the base. This restrictor limits the speed the auger is raised or lowered. Only use the cylinder provided with the auger. **DO NOT** use a cylinder that does not have the proper restrictor.

25. Hydraulic Hose Assembly

1. Thread the 90° street elbow into the upper cylinder port at the base end of cylinder.
2. Attach the swivel end of the hydraulic hose to the street elbow and tighten. (See Fig. 25-A.)
3. Starting at the cylinder end of the hose, fasten the hydraulic hose to the auger tube using the hose mounting clamps located on the half bands located along the auger tube. (See Illustrations on page 34 for the clamp locations for your size auger.)
4. Thread the female end of the shut-off valve onto the end of the hydraulic hose.

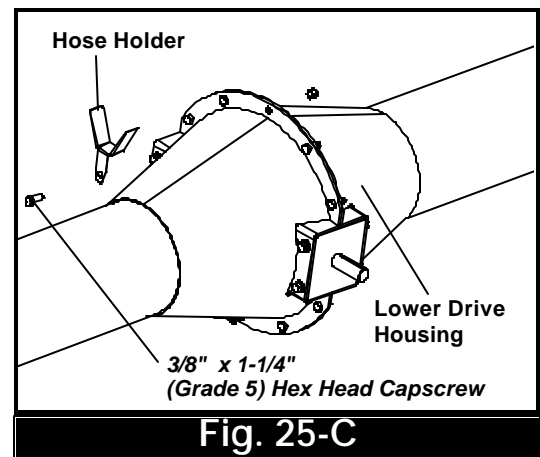
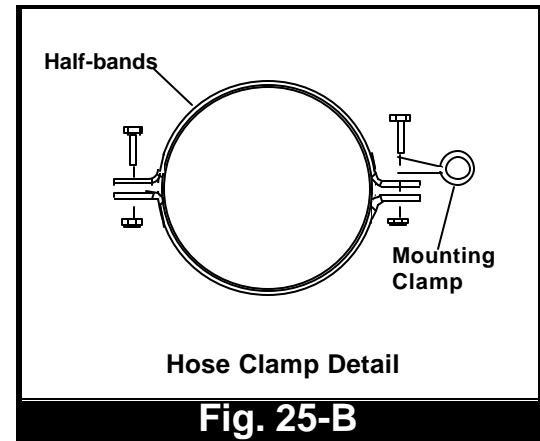
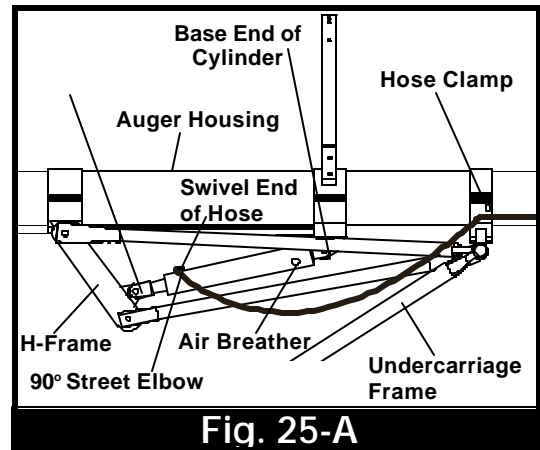

CAUTION Leave a loop of hose approximately 2'.

5. Check all of the fittings and connections to see if they are tight.
6. Attach the hydraulic hose holder to the drive housing using a 3/8" x 1-1/4" long (grade 5) hex head capscrew and lockwasher. (See figure 25-B & 25-C)

WARNING Do NOT disconnect or connect the hydraulic components when there is ANY pressure within the system. These systems are very pressurized. If any hydraulic oil is released, even an invisible leak, it can penetrate body tissues and cause critical injury. Always use a piece of cardboard or wood when searching for leaks. NEVER use hands or other body parts. Make absolutely certain that all connections are tightened during reassembly. If injured by the releasing of pressurized hydraulic oil, seek medical attention IMMEDIATELY! Severe infection or reaction is possible if medical attention is not received immediately.

Hydraulic Lift Undercarriage Models

Hydraulic Hose Clamp Locations

52' AUGER

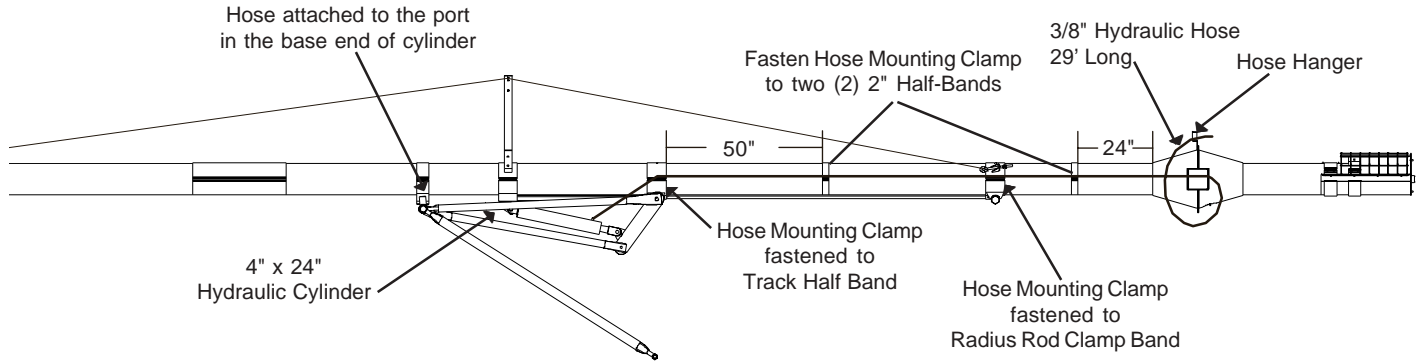

62' AUGER

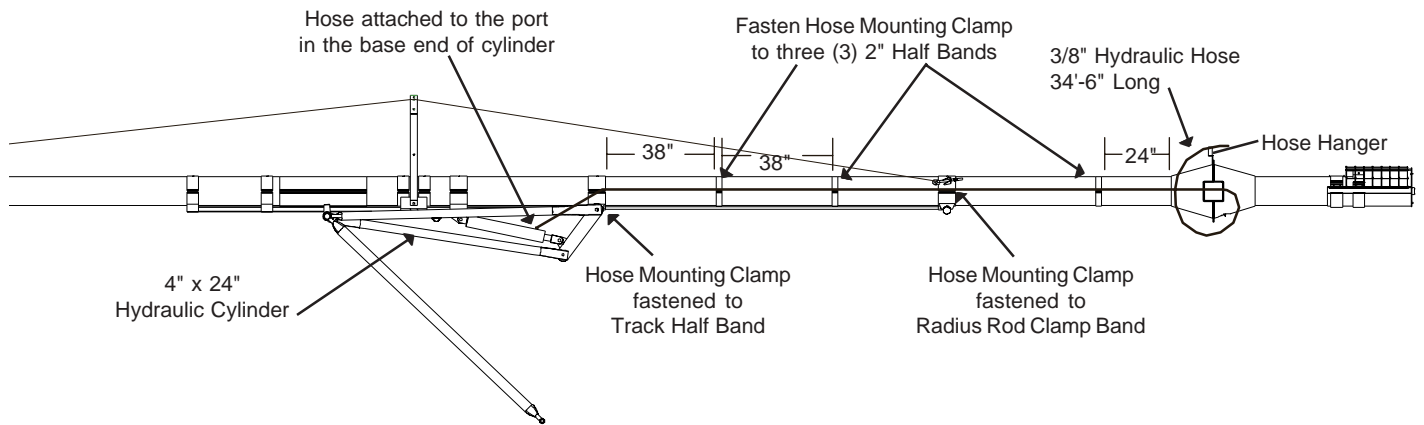

72' AUGER

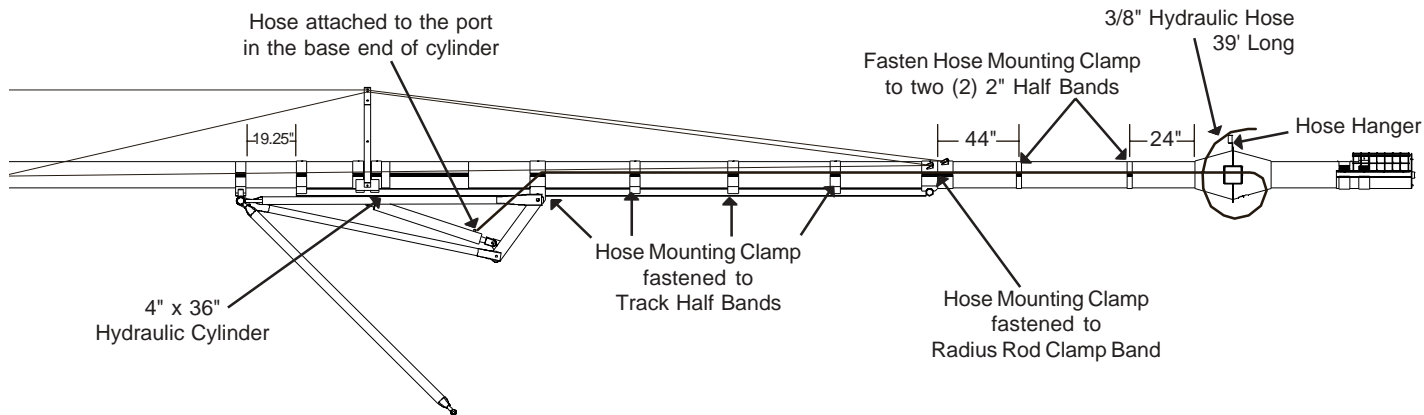

26. Assemble the Drive Kit

A. PTO Drive for 32', 42', 52', 62', 72'

Fig. 26

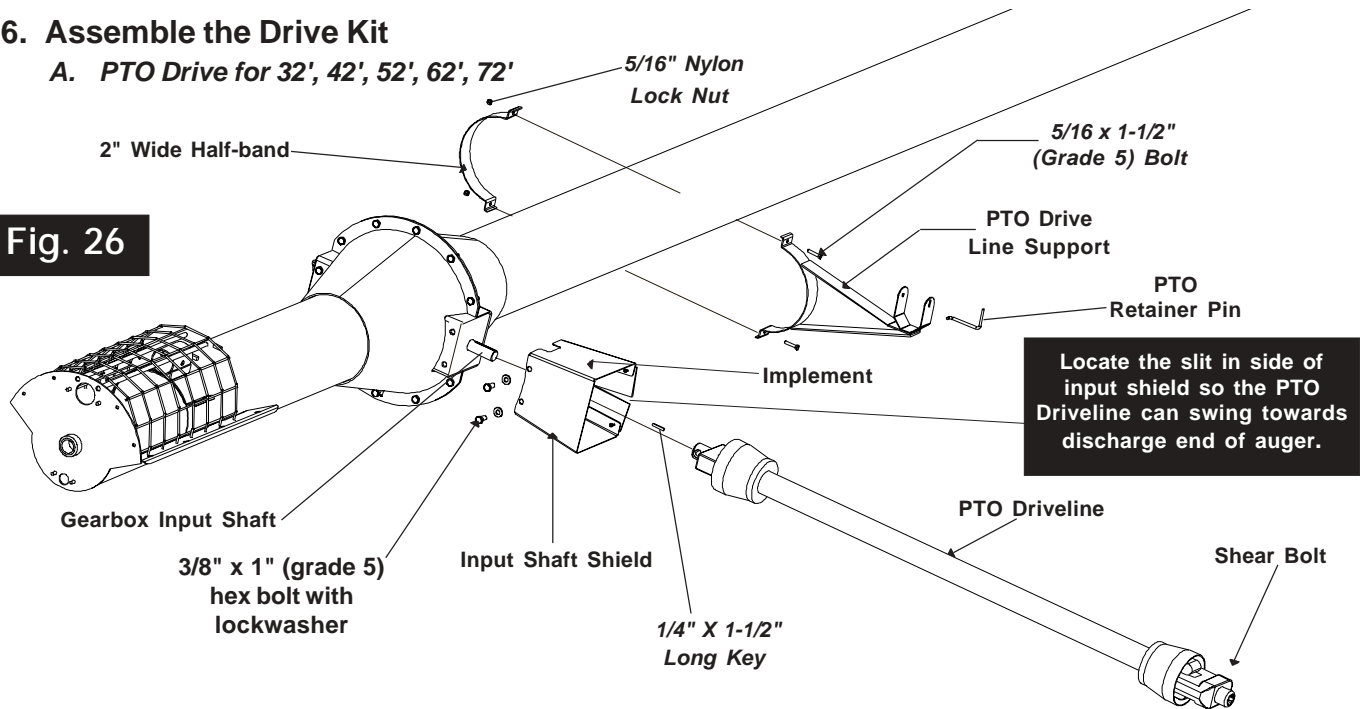

1. Place the 1/4" x 1-1/2" long square drive key into the keyway on the gearbox input shaft. Attach the PTO shaft by tightening the setscrews in the PTO driveline yoke. (See Fig. 26-A)

CAUTION The gearbox input shaft **MUST** be slid into the PTO driveline yoke until the setscrew sits on top of the flat part of the gearbox shaft for the setscrew to be engaged properly on the gearbox input shaft. Never let the gearbox input shaft extend beyond the inside end of the yoke.

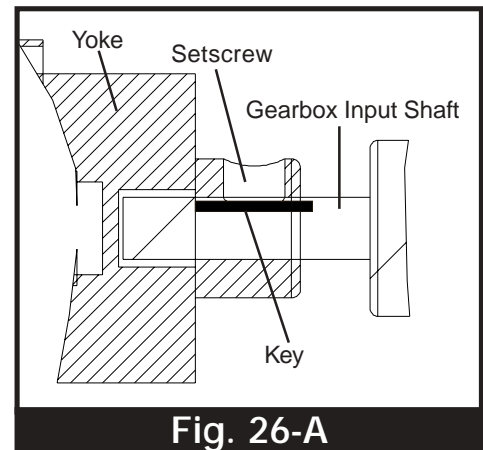

Fig. 26-A

2. Remove two (2) 3/8" x 1" grade 5 hex head capscrews that connect the mounting ear to the drive housing.
3. Place input shield over PTO driveline and fasten to drive housing using two (2) 3/8" x 1" (grade 5) hex head capscrews and nylon lockwashers. (See Fig. 26)
4. **Place the PTO driveline support 46" up the auger housing from the center of the gearbox and attach it to the auger using a half-band and two (2) 5/16" x 1-1/2" long (grade 5) hex head capscrews and nylon locknuts.** Position the PTO driveline support to the auger so that the PTO driveline is parallel with the drive shaft cover.

WARNING Do not install support where bands will cover ANY safety signs on the auger housing.

5. Attach the retaining pin by guiding the short bent end of pin first through the hole in the PTO driveline support, and then through the slot on the opposite side. Allow the long end of the pin to rotate downward. This will secure the pin in place. To take pin out rotate pin so the bent end lines up with the slot and pull it out through the holes. Set the PTO driveline into the support to be sure that the support is installed properly.

NOTE The PTO driveline is equipped with a shear bolt at the tractor connection. The shear bolt protects the auger from damage if the auger becomes plugged or subjected to high loads. It is important to use the correct replacement bolts of the proper size and strength to insure that the shear device will protect the auger and operator. Extra shear bolts are given. Order #GK2657.

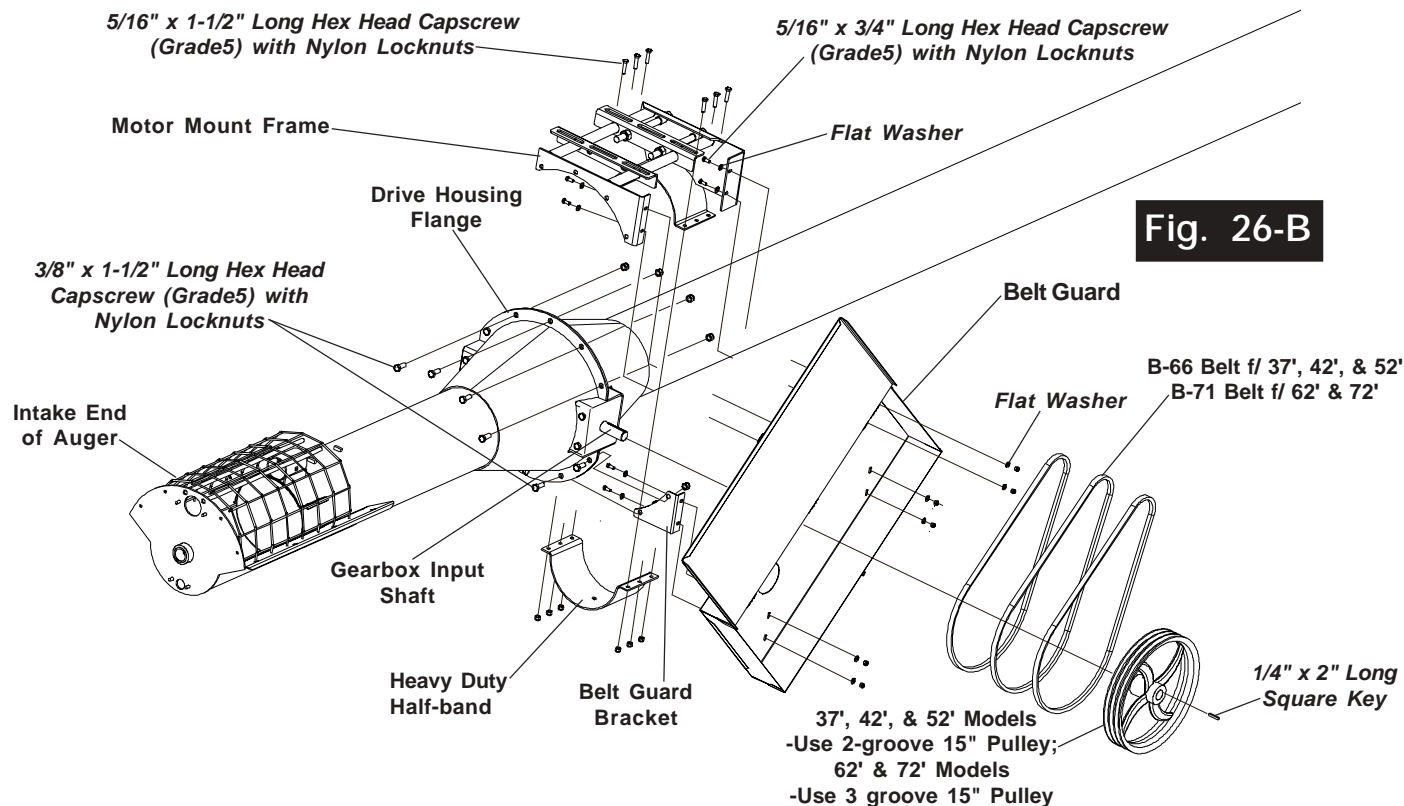
26. Assemble the Drive Kit (cont.)**B. Electric Drive for 37', 42', 52', 62', 72'**

- Slide front of motor mount frame to drive housing flange and fasten together using three (3) 3/8" x 1-1/2" hex head capscrews (grade 5) hex head capscrews and nylon lock nuts.
- Attach the back motor mount frame to the auger housing by fastening together the half band on the motor mount frame with the bottom heavy duty half-band using six (6) 5/16" x 1-1/2" hex head capscrews (grade 5) hex head capscrews and nylon lock nuts. (See Fig. 26-B)
- Bolt belt guard bracket to the drive housing flange with two (2) 3/8" x 1-1/2" (grade 5) hex head cap screws and nylon locknuts.
- Attach the belt guard bracket to the belt guard with two (2) 5/16" x 3/4" bolts, lockwashers, flatwashers and nuts.
- Secure the belt guard to the motor mount frame using four (4) 5/16" x 1" (grade 5) hex head capscrews, flat washers, and nylon locknuts.
- Attach the pulley to the gear box input shaft. Secure the pulley with 1/4" x 2" drive key. Tighten the set screws in the hub with a hex head wrench to fasten the pulley to the gearbox shaft.
- Install motor to the motor mount. **The motor, motor pulley, and the hardware used to attach the motor to the motor mount is not supplied.**
- Install the motor pulley to the motor pulley shaft.
- Install the belts.

NOTE

Use a 4-1/2" O.D. Motor Pulley.

27. Install the Hitch.

- A. Attach the hitch to the tube attachment anchor with one (1) 1/2" x 3" (grade 5) hex head capscrews, lockwasher and locknut. (See Fig. 27)

28. Operator's Manual Container.

- A. Check that an operator's manual is in the plastic container.
- B. Snap the container into the holder located in the left radius rod arm.

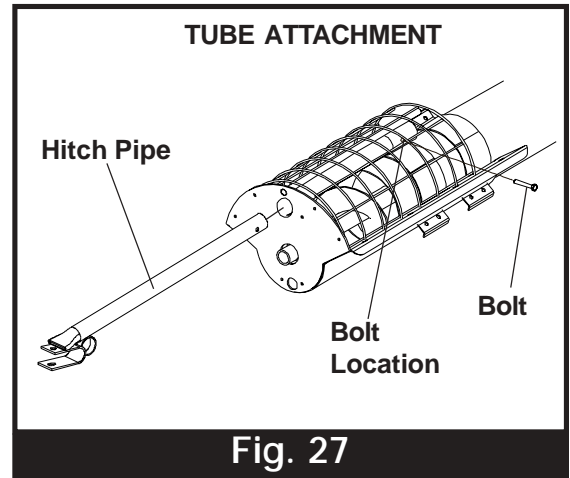

1. Designate Work Area.

- A. Before starting the auger, establish the designated work areas. The diagram below shows where boundaries should be established.
- B. Mark off the designated work areas using colored nylon or plastic rope as portable barriers.

RULES FOR SAFE WORK AREA

No matter what the circumstance, persons not involved in the operation of the auger should NEVER be allowed to trespass into the designated work area. It is the responsibility of ALL operators to ensure that children and/or other persons stay out of the designated work areas. Should anyone not involved in the operation trespass into the work area or into a hazard area, the operator should IMMEDIATELY shutdown the auger.

It is the duty of ALL operators to ensure that the work area has secure footing and is clean and free of debris and tools that might cause accidental tripping or falling. It is also the duty of the operator to keep the work area clean and organized during the operation of the auger.

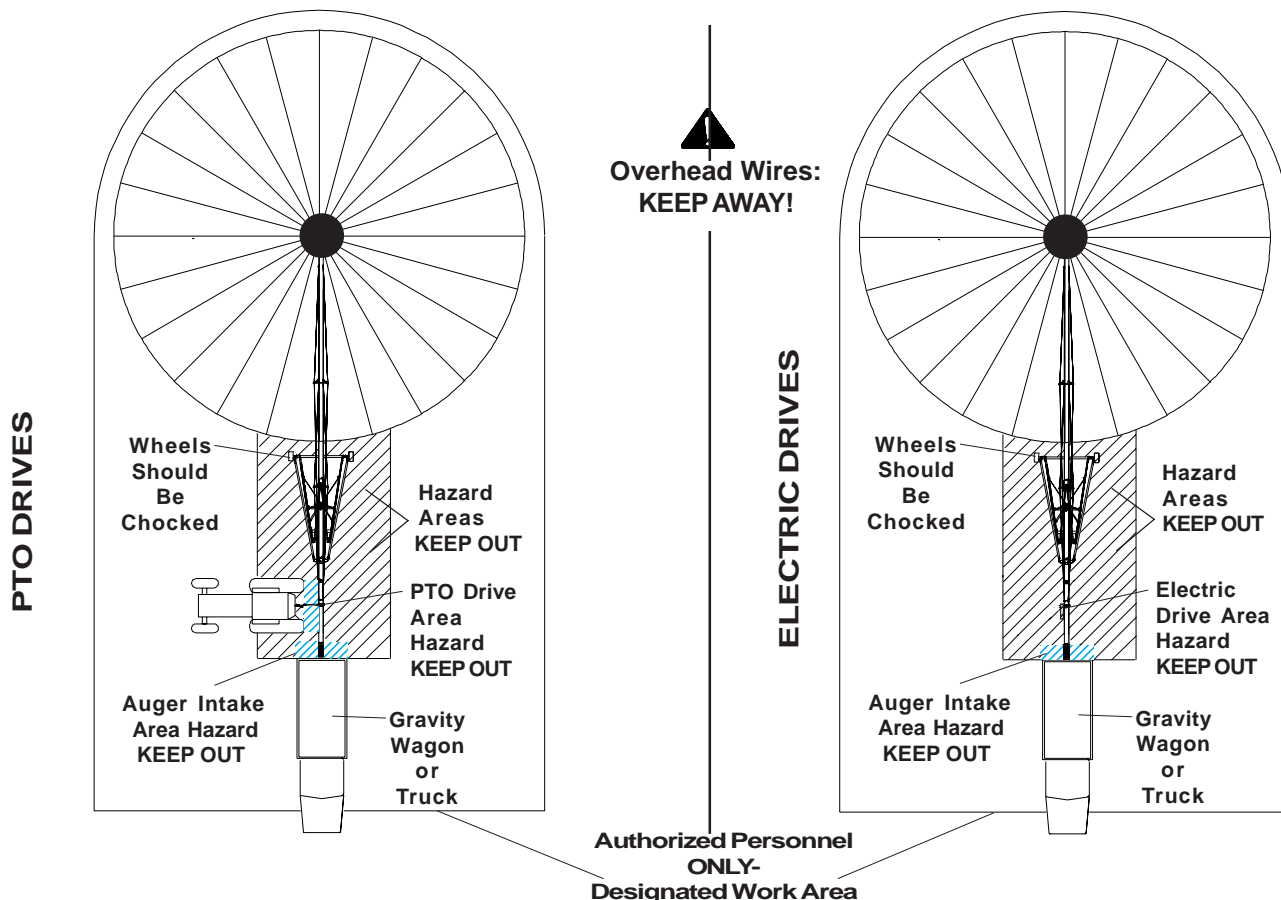

2. Inspect the Auger.

- A. After your new auger is delivered, after assembly is complete, and before each use, you must inspect the auger.
- B. Be sure that ALL guards listed in the assembly instructions are in place, secured, and functional.
- C. Be sure that the shields on the PTO rotate easily.
- D. Check ALL safety decals. Replace any that are worn, missing, or illegible. A list of decals found on the auger is included in the Decal Section of this manual. You may obtain decals from your dealer or from the factory.
- E. Check winch and cable to ensure they are secure and operational. **Replace any frayed cables.** There should be a minimum of three complete wraps of cable around the full down position winch drum, and the cable anchor has to be tight. **(for Manual Lift Augers)**
- F. Ensure that ALL fasteners are tight.
- G. Check the hydraulic hose and fittings to ensure they are tight and are not leaking hydraulic oil **(for Hydraulic Lift Augers).**
- H. Check the oil level in ALL gearboxes. The **Maintenance** section of this manual gives oil level recommendations.
- I. Ensure that all covers are in place.

3. Hitch Auger to Tractor.



Empty the machine before moving it to prevent upending.



NEVER stand between the tractor and the auger when hitching unless ALL controls are in neutral and the brakes are locked.

- A. Lift the auger intake to the height of the tractor drawbar. NEVER raise the intake end higher than necessary to attach to a towing vehicle because weight transfers rapidly to the head end when the intake is raised. It might be necessary to use assistance in the lifting process. A portable jack is recommended when necessary. Make sure the auger wheels are chocked when lifting with a portable jack.
- B. Attach the hitch clevis to the tractor drawbar using either the hitch pin and keeper or a bolt with two (2) nuts. **Refer to the figure below.** Make sure that the pin is secure and an alternate safety chain is also secured to the auger and to the tractor. Make sure that the hitch is secured to the auger. The safety chain should go through the intake safety screen and around the tow bar at the end of the intake. Route the chain through the chain support on the hitch pipe and the anchor chain to the tractor. A clevis or intermediate chain support should be fastened to the tractor drawbar NO FARTHER than 6" from the hitch pin.
- C. Connect the hydraulic hose to the tractor making sure that the hydraulic shut off valve is closed **(for hydraulic lift models).**
- D. **DO NOT** attach the PTO driveline to the tractor at this time. It will be attached after placement of the auger.

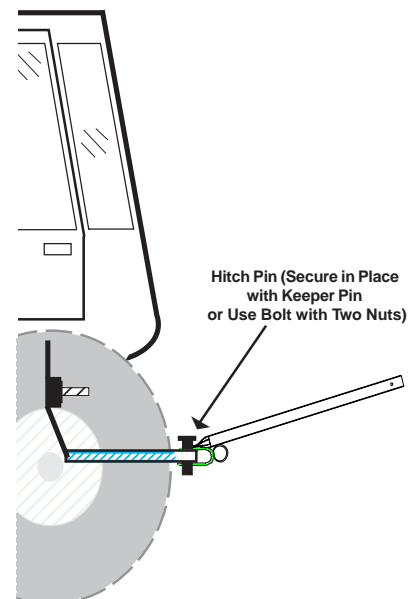

NOTE

The hydraulic shut-off valve is at the end of the hydraulic hose that connects to the tractor. The valve **MUST** be open entirely **BEFORE** raising or lowering the auger. This valve **MUST** be closed at **ALL** other times.

⚠ WARNING

Do **NOT** disconnect or connect the hydraulic components when there is **ANY** pressure within the system. These systems are very pressurized. If any hydraulic oil is released, even an invisible drip, it can penetrate body tissues and cause critical injury. Always use a piece of cardboard or wood when searching for leaks. **NEVER** use hands or other body parts. Make positively certain that all connections are tight during reassembly. If injured by this releasing pressurized hydraulic oil, seek medical attention **IMMEDIATELY!** Severe infection or reaction is possible if medical attention is not received immediately.

Hydraulic Lift Undercarriage Auger Components: Standard equipment for the auger lift system includes the hydraulic cylinder, shut-off valve, fittings, and hydraulic hose from cylinder to tractor, except for the fittings necessary to attach the hose to the tractor. The hydraulic cylinder includes a restrictor that limits the speed of operation. A vent plug is in the rod end of the cylinder, and a 1/2" female pipe thread tractor fitting (which is not furnished) is necessary to fit the hose that leads to the shut-off valve. One hydraulic control circuit with a minimum pressure of 1800 to 2000 PSI for lifting the auger is required in the hydraulic lift undercarriage.

The components that came with the hydraulic lift undercarriage were chosen to deliver the most effective and economical use. Part replacement should be the same type and size for any part replacement. Any hose or fitting that develops a leak should be replaced.

NOTE

A safety chain (auxiliary attachment system) is required on public roads to retain the connection between towing and towed machines in case the primary attachment system separates. It is not included with your auger.

4. Transporting the Auger.

- A. Before moving your portable auger, carefully consider the route you will follow to the designated work area. A route plan should be considered before hand to avoid dangerous obstacles and loss of time.
- B. If you have marked off the designated work area by using colored nylon or plastic rope as portable barriers, be sure to allow room for the tractor and auger to pass through.
- C. Move the auger with a tractor to and from the work area. If you need to move the auger over greater distances, use a pickup truck or other suitable vehicle.
- D. Follow these recommendations when transporting the auger:
 1. Always transport the auger fully lowered.
 2. Make sure the hydraulic shut off valve is closed (*for hydraulic lift models*).
 3. Make sure the hitch is secured to the tractor.

	Auger Size	Transport Height		Auger Size	Transport Height
Manual Lift	32'	8'-6" to 9'-6"	Hydraulic Lift		
	37'	8'-6"			
	42'	9'-10" to 10'-10"			
	52'	10'-10" to 11'-10"		52'	11'-6" to 12'-6"
	62'	12'-3" to 13'-3"		62'	12'-0" to 13'-0"
	72'	12'-10" to 13'-10"		72'	12'-3" to 13'-3"

NOTE Overall transport height is with the auger fully lowered and the intake on the ground. When the auger is attached to a towing vehicle, these heights will be approximately 12" less.

NOTE Be careful making turns and AVOID SHARP TURNS.

⚠ DANGER Watch for overhead obstructions and electrical wires. Failure to do so may result in electrocution. Before you begin transport, lower the auger well below the level of power lines. Maintain at least ten feet (10') of clearance. The chart above gives the recommended height of each portable auger in the lowered transport position. Refer to the chart to determine at what height you should transport your auger.

NEVER allow persons to stand under or ride on the auger during transport. Do not transport the auger at speeds in excess of 20 M.P.H. Comply with state and local regulations which govern marking towing vehicles and maximum width. Observe safe driving and operation practices.

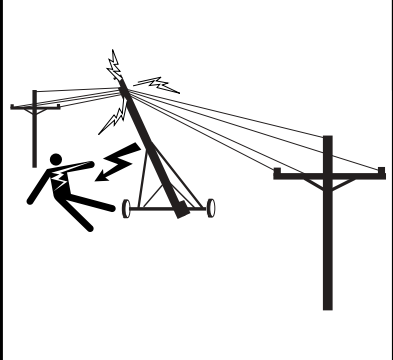

⚠ DANGER

ELECTROCUTION!!
STAY CLEAR OF POWER LINES!

- THIS EQUIPMENT IS NOT INSULATED FROM ELECTRIC SHOCK.
- KEEP EQUIPMENT AWAY FROM POWER LINES.
- ELECTROCUTION CAN OCCUR WITH OR WITHOUT DIRECT CONTACT.

FAILURE TO HEED WILL RESULT
IN SERIOUS INJURY OR DEATH!

DC-1412

5. Placing the Auger in Work Area.

Placing the Auger—Use a towing vehicle to move the auger into its working position within the designated work area. Placing the auger consists of four (4) steps:

A. Locate Auger

1. Locate the discharge end of the auger as close as possible to the bin or other structure and move the auger slowly towards the working position by using a tractor--**NOT BY HAND!!**
2. Allow room for a convenient path for the loaded vehicle to reach the auger intake.
3. The auger should be placed on a level surface, and the wheels must be allowed to roll freely when raising. The area should be clear of obstructions.
4. On Hydraulic Lift Undercarriage Models **ONLY**, open the hydraulic shut-off valve.

DANGER

Make sure everyone is clear of the work area when moving the auger. To prevent the auger from tipping over while backing, avoid rolling over ANY obstructions. Also, avoid moving the auger at right angles to a slope. If the auger is to rest on a slope, approach the bin uphill. Be certain that the entire area above the auger and in the line of travel is clear of overhead obstructions and electrical wires. Failure to do so may result in electrocution. Maintain at least ten feet (10') of clearance. Electrocution may occur even without direct contact.

B. Raise Auger

1. Raise the auger only high enough to allow minimum clearance above the bin.
2. On Hydraulic Lift Undercarriage Models **ONLY**, raise or lower the auger by using the hydraulic circuit lever that is located on the tractor.
3. On Manual Lift Undercarriage Models **ONLY**, raise or lower the auger by using the hand winch.

To raise the auger:

- A. Turn the handle, clockwise (pull cable onto winch drum.) There will be a clicking sound.
- B. The winch is supplied with a brake that is propelled by turning the handle. The brake is designed to hold the load whenever the handle is released.
- C. Watch the handle as it is winding onto the winch drum. The cable should roll up on the drum equally. Avoid cable buildup on one side of the drum.

WARNING

Keep hands away from winch drum during operation.

To lower the auger:

- A. Turn the handle, counterclockwise. There will not be a clicking sound.
- B. To stop while lowering, turn the handle clockwise until you hear two clicks to lock brake.

C. Back Into Position

1. Slowly back the auger with the tractor so that the discharge end of the auger is positioned over the bin or grain storage structure. **DO NOT** maneuver the auger by hand. Lower the auger until the auger discharge is over the bin opening.
2. Place the tractor in "Park", set the brake, and chock the auger wheels (so it will not roll when disconnected from the tractor) by placing a board or a cement block in front and behind the wheels.
3. Remove hitch pin or bolt from hitch clevis and remove bolt from hitch. Remove hitch from auger intake.
4. Install a plastic hopper at this time. (If one will be used.)
5. Lower the auger until the auger is directly over the bin opening.



The discharge end will lower as the auger fills with grain . If you discharge grain into a grain spreader, maintain at least twelve inches (12') of space between the auger discharge and the spreader. Check to make sure the spreader capacity is at or above the auger capacity.

6. On Hydraulic Lift Undercarriage Models **ONLY**, close hydraulic shut-off valve to prevent lowering; then disconnect hydraulic line from tractor.
7. The auger needs to be fastened at the intake end and/or supported at the discharge end. This will prevent the auger from tipping when weight shifts to top end as auger empties.



DO NOT increase the height of the auger by placing the wheels on blocks, lumber, or by any other means.

D. Position Tractor

for PTO drives

1. Position the tractor so the tractor and auger will be perpendicular during grain conveying operation.
2. Place the tractor in "Park" and set the brake.
3. Slide the driveline end into the tractor PTO output shaft.
4. Compress the spring keeper on the PTO driveline and continue to slide it onto the tractor PTO output shaft until the keeper sets in the groove on the tractor PTO output shaft.
5. The spring keeper returns to its original position and the PTO driveline locks onto the tractor PTO output shaft.



Make sure the tractor is perpendicular to the auger while the PTO is operating. U-Joint angles should not exceed 25 degrees for safe operation.

1. Operation Recommendations.

- A. One person must be in a position to monitor the operation of the auger at ALL times. That person should visually inspect the auger before and during operation and be alert to any unusual vibrations, noises, and the loosening of any fasteners.
- B. For smoother start-ups, allow auger to clean out completely before shutting down
- C. To avoid excessive wear, do not operate the auger empty for any length of time.
- D. You must "break-in" the auger when it is new and at the beginning of each season. Refer to Step 2: Inspecting the Auger on page 40 for instructions.
- E. Only use an Agricultural Tractor with 540 RPM Power Take-Off (PTO).
- F. To avoid damage and excessive wear of the augers:
 - Do not operate the auger at speeds in excess of 600 RPM.
 - Do not operate the auger at speeds below 425 RPM.
 - The ideal speed for the auger is 540 RPM.

⚠ DANGER

Be certain to close ALL the clean-out doors before operating the auger.

The operator should not add power before viewing the entire work area and checking that ALL personnel are clear of the designated work areas.

The operator should be alert to any unusual vibrations or noises that might indicate a need for service or repair during the initial start-up and break-in period.

The operator should regulate the grain flow into the main auger by controlling the amount of grain fed into the hopper. Avoid plugging the main auger by overfeeding the hopper.

Be certain that ALL safety shields and devices remain in place during operation.

Ensure that hands, feet, and clothing are kept away from moving parts.

Stop the engine and lockout the power source whenever the equipment must be serviced or adjusted.

2. Start-up and Break-In.

- A. Any auger that is new or has set idle for a season needs to go through a “break-in” period.
- B. Before you start the tractor, be sure the PTO driveline is securely attached to the auger and the tractor.
- C. Be sure that power to the PTO is **OFF**.

CAUTION

Be certain that the shaft shield rotates freely on the shaft before engaging the PTO driveline.

- D. Turn on the tractor.
- E. Engage the PTO at a slow RPM to minimize shock loads.
- F. Do not allow the auger flighting to “load up” at low speed. If this occurs, high torque must be used to turn the auger flighting and this can damage the auger.
- G. Run the auger at partial capacity until several hundred bushels of grain have been augered and the flighting assembly and tube are polished.
- H. When the screw and tube are polished and smooth, slowly work up to the recommended speed and run the auger at full speed.
- I. Run the auger at partial capacity when using an electric drive motor.

CAUTION

Do not stop or start the auger under load because the auger has a tendency to “freeze up”, especially if the flight and tube have not become well polished.

NOTE

You will minimize shock loads by engaging the PTO at a slow RPM, then increasing the RPM to the recommended speed.

Top Mounted Electric Motor Drive Information

- 1. Use a motor that operates at 1750 RPM.
- 2. A qualified electrician should install electric motors and controls. These motors and controls must meet the standards set by the National Electrical Code and all local and state codes.
- 3. Reset and Motor Starting Controls have to be located so the operators have an entire view of the complete operation from the control location.
- 4. To protect the motor when stopping and starting, a magnetic started must be used. This starter should be able to stop the motor in case of low voltage, motor overload, power interruption, conductor fault, or circuit interruption. The motor must be restarted manually then. Use only motors equipped with manual reset, if this type of motor is used.

1. Normal Shutdown.

- A. Make sure that the auger is empty before shutting down the unit.
- B. Slow down the RPM.
- C. Turn off the tractor or electric motor.
- D. Before the operator leaves the work area, the power source should be locked out, as described on below.

▲ WARNING

Precaution should be made to prevent anyone from operating the auger when the operator is absent from the work area. The operator must stop the auger and turn off the power source any time he/she must leave the work area, or service or

2. Intermittent Operation Shutdown.

CAUTION

Do not stop and restart the auger when it is fully loaded. This may damage the auger.

- A. During intermittent operations such as batch drying, give careful consideration to the size of auger to use. Using a larger diameter auger and reducing its load level is far better than subjecting a smaller diameter auger to high loads. An auger that is kept from absolute filling will start-up easier and convey more efficiently.

3. Emergency Shutdown.

- A. If you have to immediately shutdown the auger under load, **be sure to disconnect and lockout the power source.**
- B. Remove as much grain from the hopper and auger that you can before restarting.
- C. **Never** attempt to restart the auger when it is full.

CAUTION

Starting the auger under load may result in damage to the auger. Such damage is considered abuse of the equipment.

- D. When as much grain as possible has been cleared from the hopper and the auger, reconnect the power source and clear the remaining grain gradually.

4. Lockout.

- A. To lockout the auger, stop the auger and turn off the power supply.
- B. Remove the ignition key or coil wire from the power source. If this is not possible, remove the PTO driveline from the work area.
- C. The operator should lockout the auger in the following situations:
 - Anytime the operator leaves the work area, such as after shutdown.
 - Anytime the operator services or adjusts the auger.

5. Move Auger from Bin.

- A. Empty the auger and clean up the work area.
- B. Untie any anchors and remove all supports.
- C. Disconnect the power source. (Motor or PTO)
- D. Install hitch pipe.
- E. Remove the wheel chocks.
- F. Position tractor for attachment to the hitch pipe. (Do not attach until completing Step F.)
- G. Raise the auger so that the discharge spout is clear of the bin opening.
(**On Hydraulic Lift Undercarriage Models:** Connect the hydraulic hose to the tractor and open the hydraulic shut-off valve.)
- H. Hook hitch pipe to drawbar.
- I. With a tractor, slowly move the auger away from the bin. **DO NOT MOVE AUGER BY HAND!**

CAUTION

When moving the auger, do not make turns while the PTO driveline is attached to the tractor. Maneuvering with the PTO driveline attached will result in damage to the driveline that is not covered by the warranty.

6. Lower the Auger.

- A. Lower the auger immediately after moving the auger away from the bin or storage structure.



You should lower the auger even if you are relocating it a short distance away, such as to another bin in the immediate area.

7. Move Auger to Next Bin or Storage Area.

- A. Carefully move the auger to the next bin or storage area.
- B. It is recommended that the auger be stored in the full down position.

On Hydraulic Lift Undercarriage Models: Close the hydraulic shut-off valve to hinder the loss of hydraulic oil and disconnect the hydraulic hose from the tractor.

- C. Thoroughly inspect the auger. To allow moisture out during storage, the clean-out door on the underside of the bell housing should be left open.

8. Unhitch the Auger.



If you must disconnect the tractor from the auger in the raised position, secure the auger to the ground to prevent wind damage.

- A. Chock the auger wheels to prevent the auger from rolling.
- B. Remove the safety chain and hitch pin.
- C. Disconnect the tractor from the auger.



NEVER raise the intake end of the auger higher than is necessary to attach to a towing vehicle. When the intake end is raised, weight rapidly transfers to the intake end.

Never stand between the tractor and the auger when hitching unless all controls are in neutral and the brakes are locked.

9. Store PTO Driveline.

- A. Place the PTO driveline in storage position when it is not attached to the tractor.

NOTES

1. Lubrication Guidelines.

- A. Check and service the auger frequently to ensure economical and efficient operation of your auger. Maintaining regular and correct lubrication is key to proper maintenance. Infrequent or incorrect lubrication can result in reduced efficiency, excessive wear, and needless downtime.
- B. Refer to the drawing below to identify the parts that need lubrication and the lubrication frequency.

⚠ DANGER

NEVER perform maintenance on the auger unless all safety shields and devices are in place. Replace any that are damaged or lost. Do not clean, adjust, or lubricate any part of a machine that is in operation.

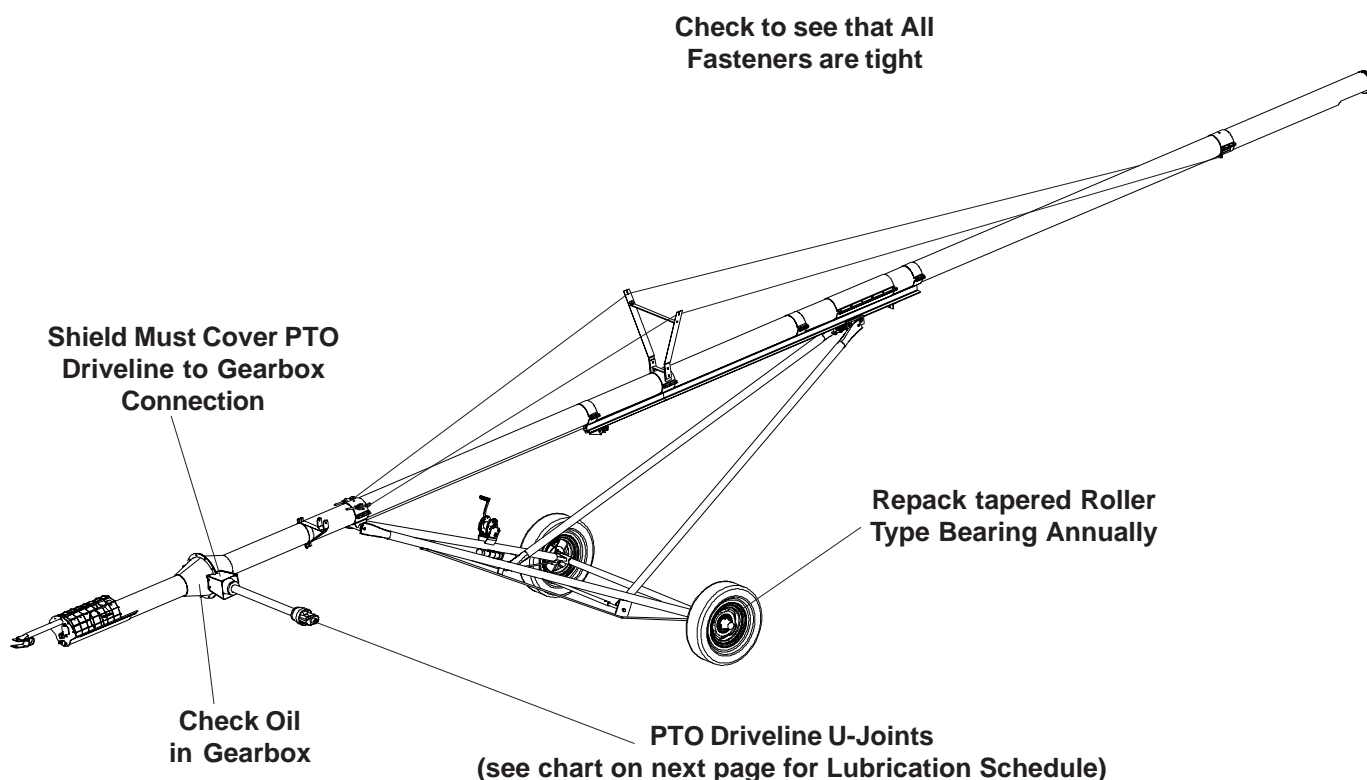

2. Winch Lubrication.

- A. Winches require the following maintenance:
 1. All gears must be covered by a film of grease at all times. Do not get oil or grease on brake disc faces.
 2. The nut holding the handle assembly must be tight.
 3. The two (2) bushings found at the end of the drum shaft, the ratchet pawl, and the bushing at the ends of the pinion shaft should be wet with oil.
 4. The teeth of the ratchet lock should be sharp, and not worn, so that they can hold the load.
 5. If the brake discs are worn to less than 1/16" thick or if they are cracked or broken, replace both discs.

⚠ WARNING

During lowering and raising of the auger, remember to:

1. Keep hands away from winch drum while operating.
2. Watch cable to see if it is coiling correctly and evenly onto the winch drum and don't use hands to guide cable onto winch drum during winch operation.
3. Do not allow auger to become hung up.
4. Do not keep raising auger after slide reaches stop.

3. PTO Driveline U-Joint Lubrication.

A. You must lubricate the fittings on the PTO driveline. The drawing below identifies the location of the fittings.

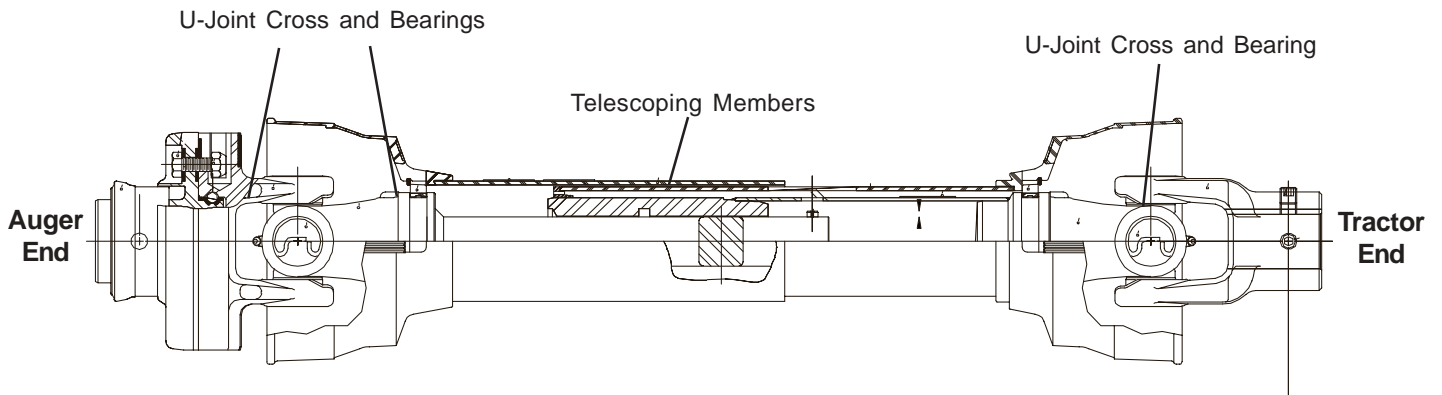

B. To lubricate the auger end of the PTO driveline, you need to rotate up the shaft shield. Refer to the drawing on the previous page for the location of the shield.

C. Apply the first lubrication after the initial start-up and after 16–24 hours of operation, then follow this schedule:

Constant Angle Lube Recommendations		
Interval	Location	Amount
4 hrs.	U-Joint Cross & Bearings	1 Pump
8 hrs.	Telescoping Members	4-8 Pumps

D. Use a good quality grease. (Example: Shell super duty, or equivalent)

F. Be sure to return the shaft shield. Refer to the drawing on the previous page for the location of the shield.

4. PTO Driveline Replacement Parts.

A. To ensure optimal performance from your auger, any parts for replacement should be replaced with parts of the same type and size. Do not modify or alter any of the auger components, such as using a part that exceeds the maximum recommended operating length of PTO driveline.

▲ CAUTION PTO driveline replacement parts do not come lubricated. Lubricate them at the time of assembly.

B. When lubricating PTO driveline replacement parts, refer to the chart above to determine the amount of lubrication and the recommended intervals.

5. PTO Driveline Shear Bolt.

- A. The PTO driveline shear bolt is located at the tractor connection. The shear bolt protects the auger from damage if the auger is subjected to high loads or becomes plugged.
- B. Use a replacement bolt of the proper size and strength to ensure that the shear device will protect the auger and operator. Refer to the chart below for the correct size and strength.

PTO Driveline Shear Bolt			
Auger Size	Shear Bolt Size	Shear Bolt Grade	Replacement Shear Bolt Part No.
8" dia.	5/16" - 18 x 1" long	Grade 5	GK2657

- C. Extra shear bolts are supplied with the auger. They are stored in the operator’s manual container located on the left radius rod.

6. Belt Adjustment.

- A. The belt tension will need periodic adjustments on drives that use belts for power.

7. Hydraulic Cylinder. (On Hydraulic Lift Undercarriage Models.)

The hydraulic cylinder is made with an air breather located in the rod end port.

1. Make sure that the air breather is not plugged.
2. Examine the rod seals to see if they are leaking. Replace damaged or leaking seals.
3. Examine the cylinder and see if it is fastened tightly to the lifting mounts.

8. Hose. (on Hydraulic Lift Undercarriage Models.)

- A. Examine the hydraulic hose and all the fittings to see if they are tight and are not leaking hydraulic oil. Change the hose if it is damaged.



⚠ DANGER Do NOT disconnect or connect the hydraulic components when there is ANY pressure within the system. These systems are very pressurized. If any hydraulic oil is released, even an invisible drip, it can penetrate body tissues and cause critical injury. Always use a piece of cardboard or wood when searching for leaks. NEVER use hands or other body parts. Make positively certain that all connections are tight during reassembly. If injured by this releasing pressurized hydraulic oil, seek medical attention IMMEDIATELY! Severe infection or reaction is possible if medical attention is not received

9. Bearings

A. Intake guard bronze bearing

1. Each auger has a bronze bearing located at the intake end. This bearing requires no lubrication. If the wire guard is damaged, contact dealer and replace.

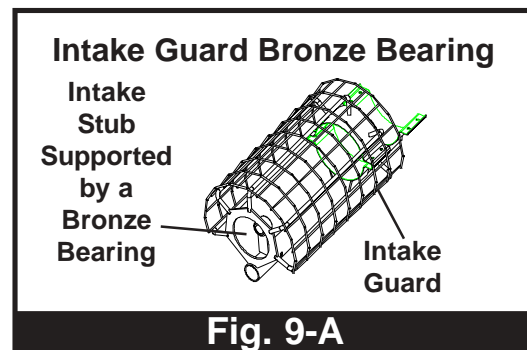

9. Bearings (cont.)

B. Undercarriage axle spindle bearing:

1. The auger spindles have tapered roller type bearings. They need to be repacked with grease and modified at least once per year or as needed. This is determined by the auger's usage.

Care must be used in taking apart the tapered roller bearings:

1. Remove the dust cap by pushing around its edges.
2. Remove the cotter pin, slotted nut, and flatwasher.
3. Remove the hub and bearings with caution from the spindle.
4. Thoroughly inspect all parts for wear or damage and replace with new ones, if needed.

When reassembling the hub:

1. Refill the bearing cones with grease and fill hub cavity 1/3 full.
2. Position the inner bearing assemblies into the hub.
3. Press the grease seal into the hub and reinstall the hub onto the spindle. **When placing the hub on the spindle, be careful not to damage the lip of the grease seal.**
4. Place the outer bearing assembly into the hub, and replace the flat washer and slotted nut. Tighten the slotted nut to seal the bearings until the hub binds as you rotate the hub. Back off the slotted nut to the next slot and pin with a new cotter pin. Use a 5/32" cotter pin 1-1/4" long.
5. Replace the dust cap.

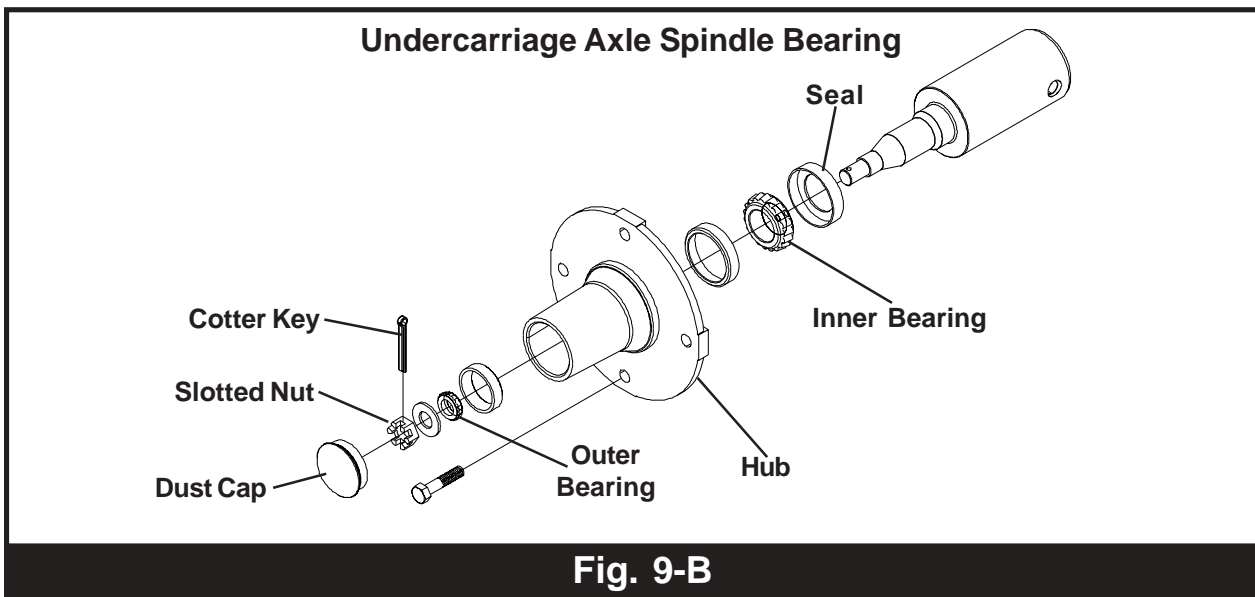

10. Blow-off Cap

Removal and reinstallation of the cap is necessary before each seasonal use. The cap should be able to slide off the end of the tube if the discharge becomes plugged, but the cap should fit onto the end snug. It should be possible to tap the cap off by hand.

<i>Problem</i>	<i>Possible Cause</i>	<i>Solution</i>
1. The auger is vibrating.	A. Damage can occur to the auger flighting, causing noise. Damage usually is caused from foreign material being run through the auger.	A1. It may be necessary to remove the flighting for inspection.
2. Capacity is too low.	A. There may not be enough grain reaching the auger.	A1. Make sure the intake has not bridged over, restricting flow. The flighting at the intake should be covered with grain for maximum capacity.
	B. The auger is moving too slowly.	B1. Check the auger speed. Low capacity will result from speeds slower than recommended.
3. The auger plugs.	A. The auger may be "jamming" because too much grain is reaching the auger.	A1. Decrease the amount of grain flowing into the auger.
	B. The grain may be wet.	B1. If wet grain or other hard-to-move material is being augered, reduce the amount of grain being fed into the hopper.
	C. The auger may be jammed with foreign material.	C1. Remove any foreign material in the auger.
	D. The discharge end may be plugged.	D1. Unplug any plugs at the discharge end of the auger.

<i>Problem</i>	<i>Possible Cause</i>	<i>Solution</i>
6. Driveline shear bolt shears frequently.	A. Grain may be flowing too quickly into the hopper.	A1. Reduce the flow rate of grain into the hopper.
	B. The discharge of grain from the main auger may be restricted.	B1. Inspect auger intake and discharge areas for damage.
7. Auger Lowering by Itself (Hydraulic Lift Undercarriage Augers ONLY)	A. Hydraulic fittings, hose, and connections could be leaking.	A1. Check that the hydraulic shut-off valve is closed.
8. Auger Will NOT Raise or Lower (Hydraulic Lift Undercarriage Augers ONLY)	A. The hydraulic coupler may not be properly attached to the tractor and the tractor reservoir is full of oil.	A1. Check that the hydraulic shut-off valve is open.

Main Auger Components

**52' Auger Shown
w/ Manual Lift Undercarriage
(Figure 1)**

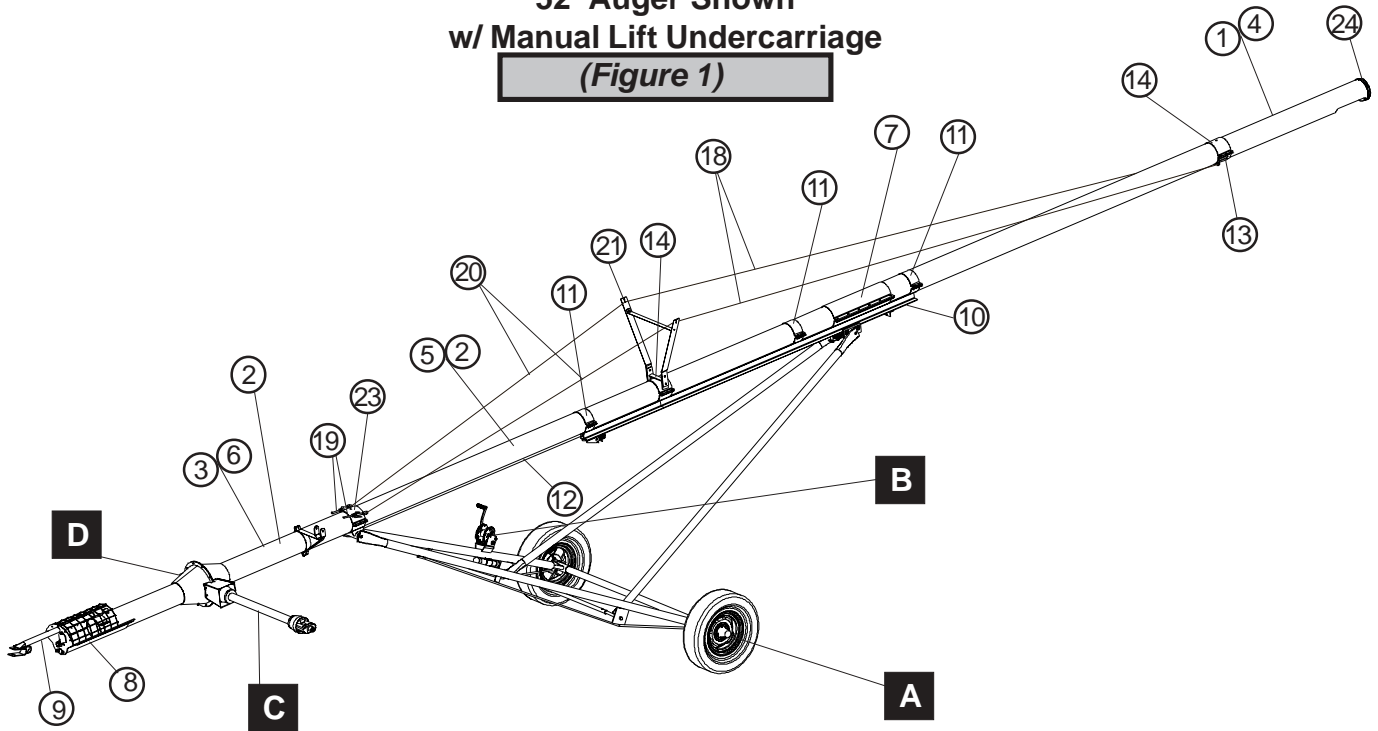

Pre-Assembled or Purchased Components

Items listed below can be ordered as complete assemblies, or individual components can be selected by referring to their parts breakdowns listed on other pages.

Ref Letter	Part #	Description
A	GK2705	Spindle & Hub Assembly 4-Bolt (for 32')- <i>see page 65 for parts breakdown</i>
	GK1193	Spindle & Hub Assembly 4-Bolt (for 37', 42', 52', 62' and 72')- <i>see page 65 for parts breakdown</i>
B	GK1562	Winch K-1000 Brake Type for 8" x 32' - <i>see page 70 for parts breakdown</i>
	GK3337	Winch K-1500 Brake Type for 8" x 37' thru 62' - <i>see page 71 for parts breakdown</i>
	GK2490	Winch K-2500 Brake Type for 8" x 72' - <i>see page 72 for parts breakdown</i>
C	GK1514	Implement Input Driveline (I.I.D.) for 8" x 32, 37', 42', 52', 62', and 72'- <i>see page 73 for parts breakdown</i>
D	GK2498	Gearbox for 8" x 32' thru 72' Direct PTO and Top Mounted Electric

Miscellaneous Components		
Ref. No.	Part No.	Description
N/S	GK1564	Corn Screen Cover 8"
N/S	GK1565	Corn Screen Cover Band 8"
N/S	GK1523	Manual Container with caps
N/S	GK3089	Cap for Manual Container
24	GK1547	Blow off Cap
N/S	GK1241	Chain for Blow Off Cap

Main Auger Components

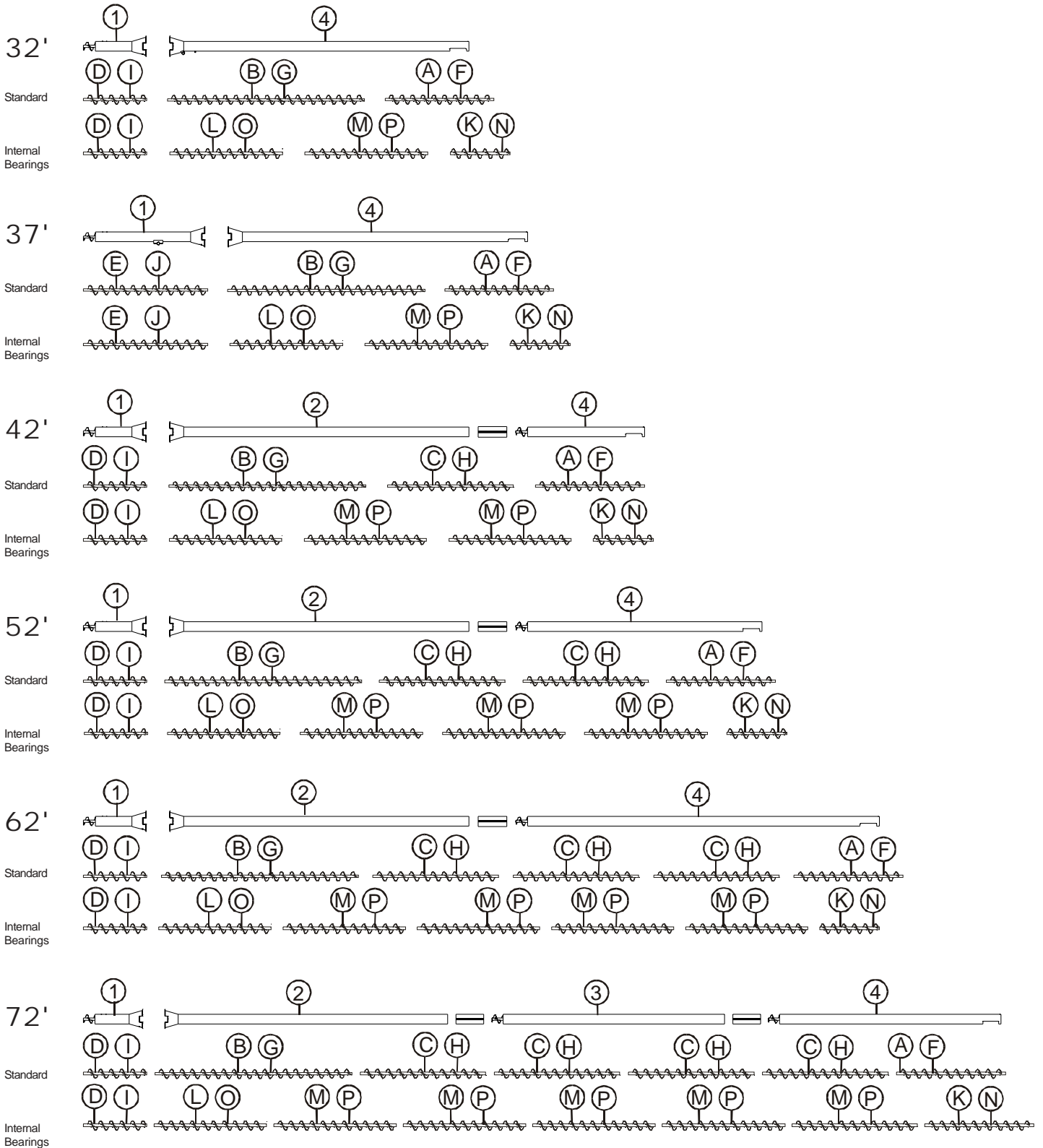

Auger Flight Sections

Standard - Medium Duty Flight (7 Ga. On 1.9" O.D. Tubing)		
Ref. No.	Part No.	Description
A	***** GK3813	Upper Flight Section for 32', 37', 42', 52', 62', & 72'
B	***** GK3811	Middle Flight Section Tapered Flight for 32', 37', 42', 52', 62', & 72' for 42', 52' @ 2, 62' @ 3, & 72 @ 4
C	GK3812	
D	***** GK3801	Lower Flight Section for 32', 42', 52', 62', & 72'
E	GK3849	for 37'

Standard- Heavy Duty Flight (1/4" On 1.9" O.D. Tubing)		
Ref. No.	Part No.	Description
F	***** GK3817	Upper Flight Section for 32' - 72'
G	***** GK3815	Middle Flight Section Tapered Flight for 32', 37', 42', 52', 62', & 72' for 42', 52' @ 2, 62' @ 3, & 72 @ 4
H	GK3816	
I	***** GK3814	Lower Flight Section for 32', 42', 52', 62', & 72'
J	GK3851	for 37'

Internal Bearing - Medium Duty Flight (7 Ga. On 1.9" O.D. Tubing)		
Ref. No.	Part No.	Description
K	***** GK3839	Upper Flight Section for 32', 37', 42', 52', 62', & 72'
L	***** GK3837	Middle Flight Section Tapered Flight for 32', 37', 42', 52', 62', & 72' for 32', 37', 42' @ 2, 52' @ 3, 62' @ 4, & 72 @ 5
M	GK3838	
D	***** GK3801	Lower Flight Section for 32', 42', 52', 62', & 72'
E	GK3849	for 37'

Internal Bearing - Heavy Duty Flight (1/4" on 1.9" O.D. Tubing)		
Ref. No.	Part No.	Description
N	***** GK3842	Upper Flight Section for 32', 37', 42', 52', 62', & 72'
O	***** GK3840	Middle Flight Section Tapered Flight for 32', 37', 42', 52', 62', & 72' for 32', 37', 42' @ 2, 52' @ 3, 62' @ 4, & 72 @ 5
P	GK3841	
I	***** GK3814	Lower Flight Section for 32', 42', 52', 62', & 72'
J	GK3851	for 37'

Main Auger Components

There are different types of auger housings which depend upon what options your auger is equipped with. Select the auger housing that goes with the auger you were shipped.

Standard Duty Auger Tube (14 Gauge)

STANDARD AUGER HOUSING (See page 58)		
Ref. No.	Part No.	Description
1	*****	Lower Section w/ Bell Housing
	GK3930	for 32', 42', 52', 62', & 72'
2	GK3974	for 37'
	*****	Middle Section w/ Bell Housing
3	GK3697	for 42', 52', 62', & 72'
	*****	Middle Section
4	GK3692	for 72'
	*****	Upper Section w/ Discharge
	GK3696	for 32'
	GK4159	for 37'
	GK3693	for 42'
	GK3694	for 52' & 72'
	GK3695	for 62'

INTERNAL BEARING AUGER HOUSING (See page 58)		
Ref. No.	Part No.	Description
1	*****	Lower Section w/ Bell Housing
	GK3930	for 32', 42', 52', 62', & 72'
2	GK3974	for 37'
	*****	Middle Section w/ Bell Housing
3	GK4635	for 42', 52', 62', & 72'
	*****	Middle Section
4	GK4632	for 72'
	*****	Upper Section w/ Discharge
	GK4426	for 32'
	GK4427	for 37'
	GK4634	for 42'
	GK4631	for 52' & 72'
	GK4633	for 62'

Auger Housing Components		
Ref. No.	Part No.	Description
7	GK1015	Connecting Band for 42', 52', 62', & 72' <i>Note: 72' will use two (2) GK 1015</i>
8	GK3144	Hopper Style Intake Guard
9	GK1401	Hitch Pipe
N/S	GK3501	Open Bottom Intake Guard
N/S	GK5118	Half Band for GK2146 Intake Guard

Flight Connecting Hardware		
Ref. No.	Part No.	Description
N/S	S-8316	Connecting Bolt 7/16 x 3" (grade 8)
N/S	S-8317	7/16" Stover Type Locknut

Optional internal Bearing Components		
Ref. No.	Part No.	Description
6a	GK1263	Internal Bearing Hanger w/ Bronze Bushing
N/S	GK1192	Replacement Bronze Bushing
6b	GK3670	Cover: Inspection Hole Large 10"
N/S	GK4052	Connecting Band with Slot <i>Note: 72' will use two (2) Bands</i>
N/S	GK1736	Flight Connecting Stub

Manual Lift Track Components		
Ref. No.	Part No.	Description
10	*****	Track
	GK1182	for 32'
	GK4154	for 37'
	GK1399	for 42'
	GK1396	for 52'
	GK2133	for 62'
	GK4195	for 72'
11	GK5118	Plain Track Half Band (4" Wide)
12	*****	Spacer Tube
	GK1181	for 32'
	GK3341	for 37' & 42'
	GK1387	for 52'
	GK2435	for 62'
	GK1140	for 72'

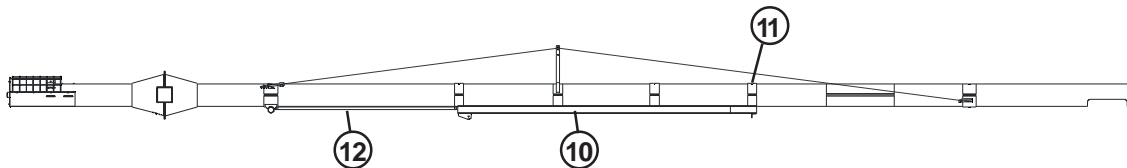

Manual Lift Undercarriage Components		
Ref. No.	Part No.	Description
1	GK1316	Radius Rod Clamp
2	GK1549	Radius Rod Spacer Tuber (8-1/4" long)
3	S-8259	Bolt 3/4" x 11" long HHCS
4	*****	Axle
	GK1149	for 32'
	GK1546	for 37', 42', & 52'
	GK2056	for 62'
	GK2627	for 72'
5	*****	Right Radius Rod
	GK3275	for 32'
	GK1421	for 37' & 42'
	GK2550	for 52'
	GK2058	for 62'
	GK3358	for 72'
6	*****	Left Radius Rod (with winch mount)
	GK3274	for 32'
	GK1416	for 37' & 42'
	GK2551	for 52'
	GK2059	for 62'
	GK3101	for 72'
7	*****	Axle Spacer Tube
	GK1180	for 32'
	GK1418	for 37' & 42'
	GK1031	for 52'
	GK2057	for 62'
	GK3366	for 72'
8	*****	Axle Legs
	GK3195	for 32'
	GK1419	for 37' & 42'
	GK2554	for 52'
	GK2060	for 62'
	GK3196	for 72'
9	GK1394	Axle Leg Cross Braces (for 72' only)
10	GK1175	Trolley (w/ steel rollers)
11	GK1179	Trolley Spacer Bushing (4-3/4" long)
12	S-8352	Bolt 3/4" x 7" long HHCS (grade5)
13	GK1150	Trolley Pulley Clevis
14	GK1453	Pulley Clevis Bushing (1-5/8" long)
15	GK1543	1/4" Cable Pulley
16	GK1294	10 ga. Washer
17	GK1391	Track Pulley Clevis
18	GK1545	Pulley Straps for Radius Rod
19	GK1544	Cable Pulley Bushing
20	*****	Lift Cable for
	GK1594	for 32'
	GK1589	for 37' & 42'
	GK1606	for 52'
	GK2229	for 62'
	GK3322	for 72'
21	GK2761	1/4" Cable Clamp
22	GK1562	Winch (1000#)-see page 70 for parts break down
22	GK3337	Winch (1500#)-see page 71 for parts break down
22	GK2490	Winch (2500#)-see page 72 for parts break down
23	*****	Spindle & Hub Assembly-see page 65 for parts break down
	GK2705	for 32'
	GK1193	for 37', 42', 52', 62', & 72'
24	GK1176	Wheel Rim (4-bolt)

Manual Lift Undercarriage Components

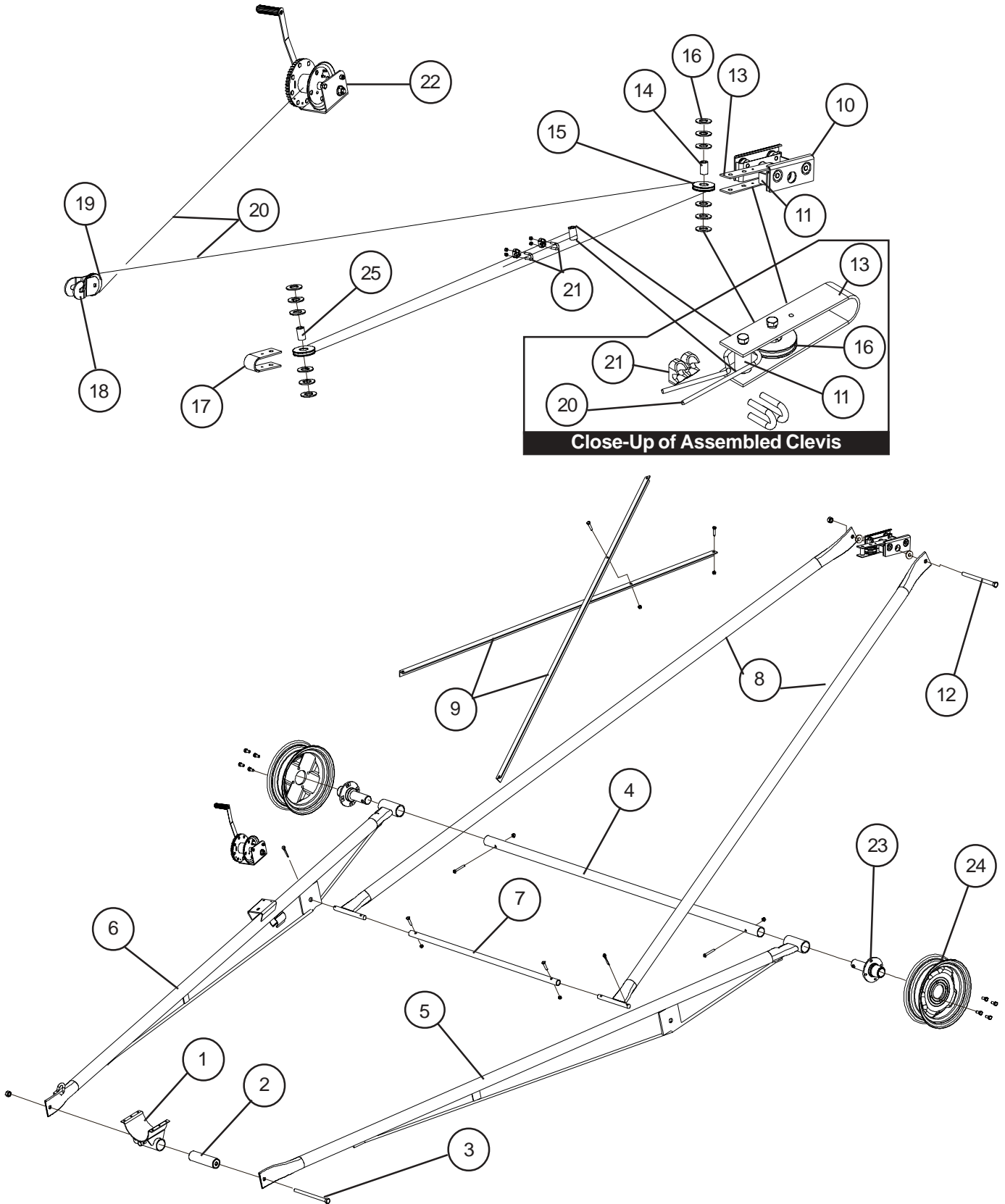

Hydraulic Lift Undercarriage Components

Ref No.	Part No.	Description
1	GK1316	Radius Rod Clamp (52'-62' Models)
2	GK1549	Radius rod spacer tube (8-1/4" long)
3	S-8259	Bolt 3/4" x 11" HHCS
4	*****	Axle
	GK1546	for 52' (94-1/2" long)
	GK2056	for 62' (93" long)
	GK2627	for 72' (120" long)
5	*****	Right radius rod
	GK2550	for 52' (12' - 2" long)
	GK2058	for 62' (14' 8-1/2" long)
	GK3101	for 72' (17' 5-1/4" long)
6	*****	Left radius rod (with winch mount)
	GK2551	for 52' (12' - 2" long)
	GK2059	for 62' (14' 8-1/2" long)
	GK3358	for 72' (17' 5-1/4" long)
7	*****	Undercarriage Assembly
	GK2614	for 52'
	GK3356	for 62'
	GK3357	for 72'
8	*****	Undercarriage H-Frame Tube
	GK2528	for 52' (64" long)
	GK2529	for 62' (82" long)
	GK3082	for 72' (96 1/2" long)
9	*****	H-Frame
	GK1450	for 52' and 62'
	GK3359	for 72'
10	*****	Hydraulic cylinder
		<i>see page 74 for parts breakdown</i>
	GK1527	for 52' and 62' ; 4" bore x 24" stroke
	GK1528	for 72' ; 4" bore x 36" stroke
11	*****	Track
	GK3243	for 52'
	GK3355	for 62'
	GK3517	for 72'
12	*****	H-Frame spacer tube
	GK2267	for 52' and 62' (8 1/4" long)
	GK3523	for 72' (9 1/4" long)
13	*****	Bolt for H-frame tube
	S-8419	for 52' and 62' (1" x 11" long)
	S-8417	for 72' (1" x 12")
14	*****	Rest plate
	GK3429	for 52'
	GK4299	for 72'
15	GK1533	Hydraulic shutoff valve
16	GK1336	90° Elbow
17	*****	Hydraulic hose
	GK3519	for 52' (3/8" x 29')
	GK3520	for 62' (3/8" x 34')
	GK3521	for 72' (3/8" x 39')
18	GK1315	Hose mounting clamp
19	GK1057	2" x 10" Half band
20	GK1193	Spindle and Hub Assembly (52', 62' and 72' Models)see pg 65 for parts breakdown
21	GK1176	Wheel rim (4-bolt)

Hydraulic Lift Undercarriage Components

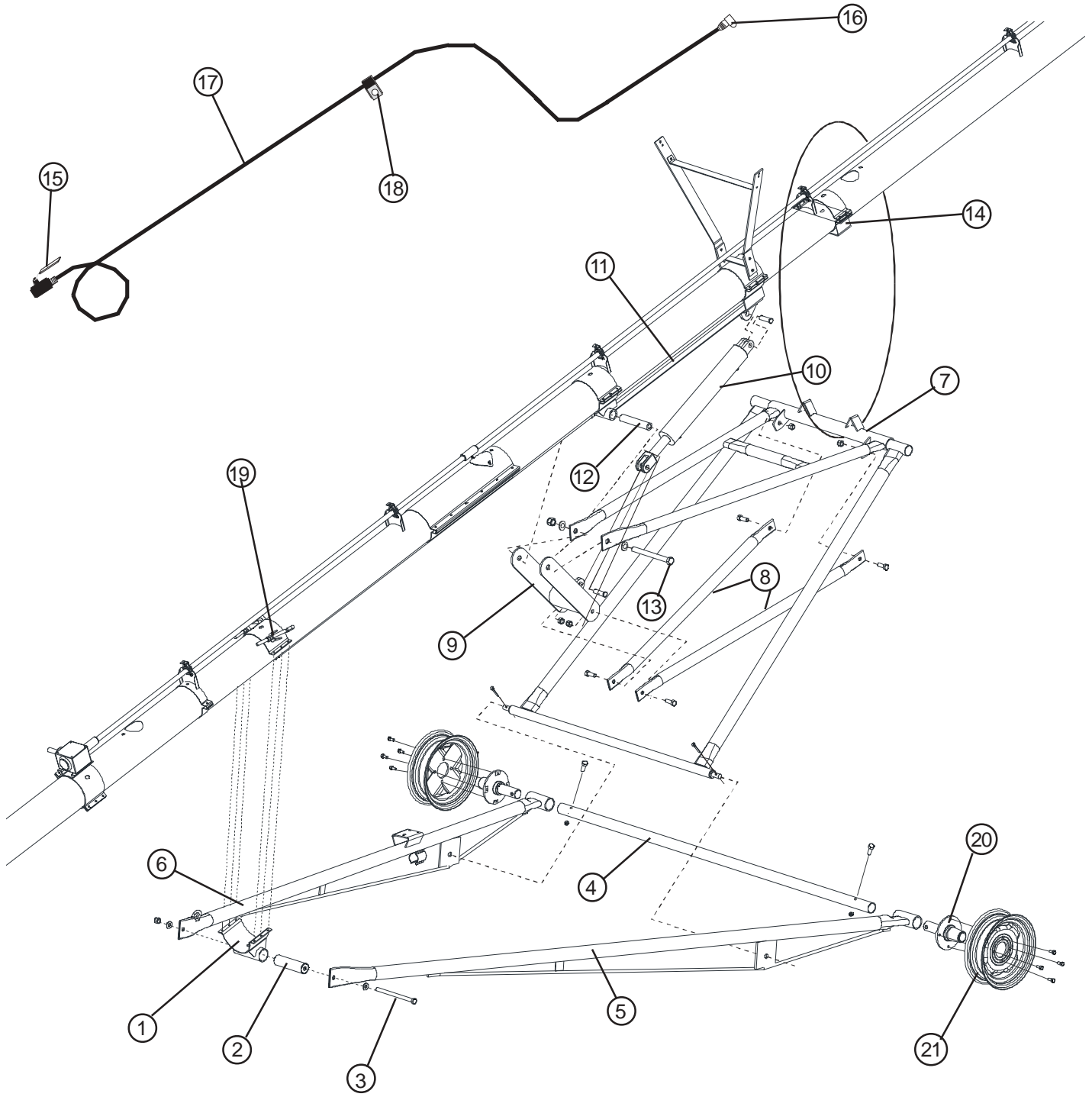

Truss Components

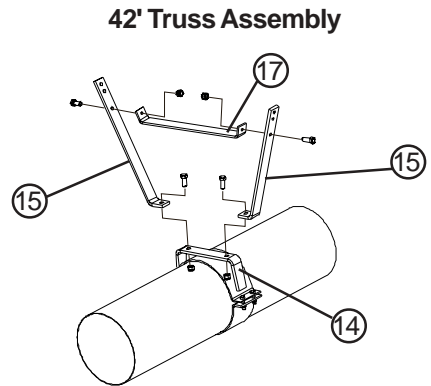
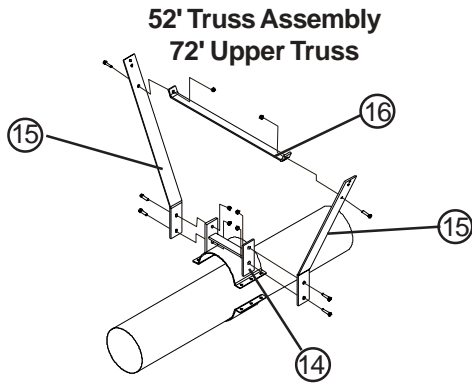
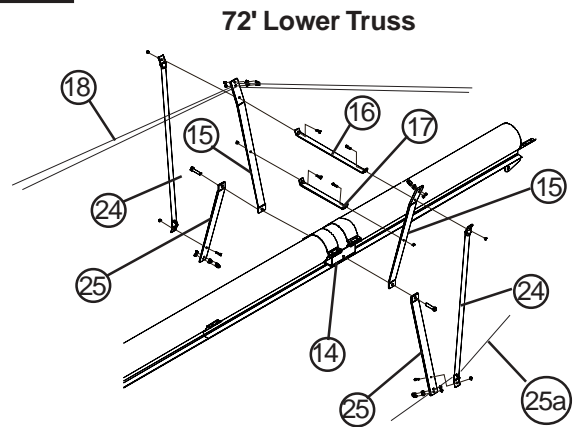
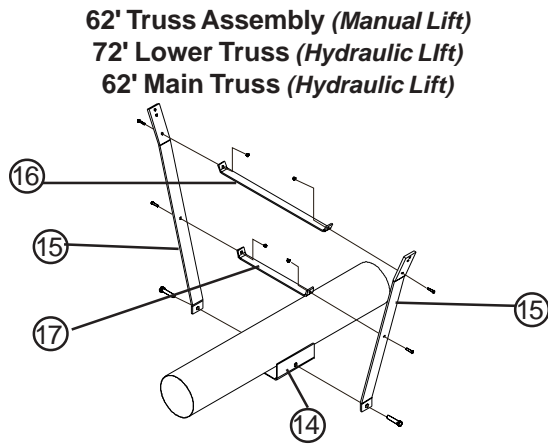

Figure 2



Truss Components

Ref. No.	Part No.	Description
13	GK1183	Upper Band-on Truss Anchor for 42', 52', 62', & 72'
13a	GK1326	Heavy Duty Half-Band
14	*****	Truss Mount
	GK1397	for 42' Main Truss
	GK1068	for 52' Main Truss; 72' Upper Truss
15	*****	Truss Side Straps
	GK1552	for 42' Main Truss (19" long)
	GK1555	for 52' Main Truss; 72' Upper Truss (32' long)
	GK2536	for 62' & 72' Main (39-1/2" long)
16	*****	Truss Crossbrace
	GK1568	for 42' Main
	GK1554	for 52, 62', & 72' Main; 72' Upper Truss (top) 28" long
17	GK1016	for 62' & 72' Main Truss (bottom) (15-5/8" long)
18	*****	Truss Cable
	GK1575	for 42' (1/4" x 28' long)
	GK3332	for 52' (1/4" x 36' long)
	GK1582	for 62' (5/16" x 52' long)
	GK2167	for 72' winch lift (5/16" x 31' long)
25a	GK2167	Undertruss cable (5/16" x 31'-0") for 72' only
19	GK3107	Eyebolt 5/8" dia.
20	GK2761	Cable Clamp 1/4"
20	GK2760	Cable Clamp 5/16"
21	GK2759	Cable Clamp 3/8" for 42', 52', & 62' main & 72' upper truss
23	GK1030	Lower band on truss anchor
24	GK1395	Truss vertical tube 56-5/8" long for 72' only
25	GK1393	Undertruss side strap 30" long for 72' only

Direct PTO Drive Components

Ref No.	Part No.	Description
26	GK1514	PTO Driveline
27	GK1566	Sq. key 1/4" x 1-1/2" long
28	GK3343	PTO Carrier Bracket
29	GK4160	PTO Gearbox Shield
30	GK3246	Retainer Pin
31	GK1055	Half band 2" wide
32	GK4110	Access Cover
33	GK2498	Gearbox 1:1
	GK2499	Gearbox 1.35:1

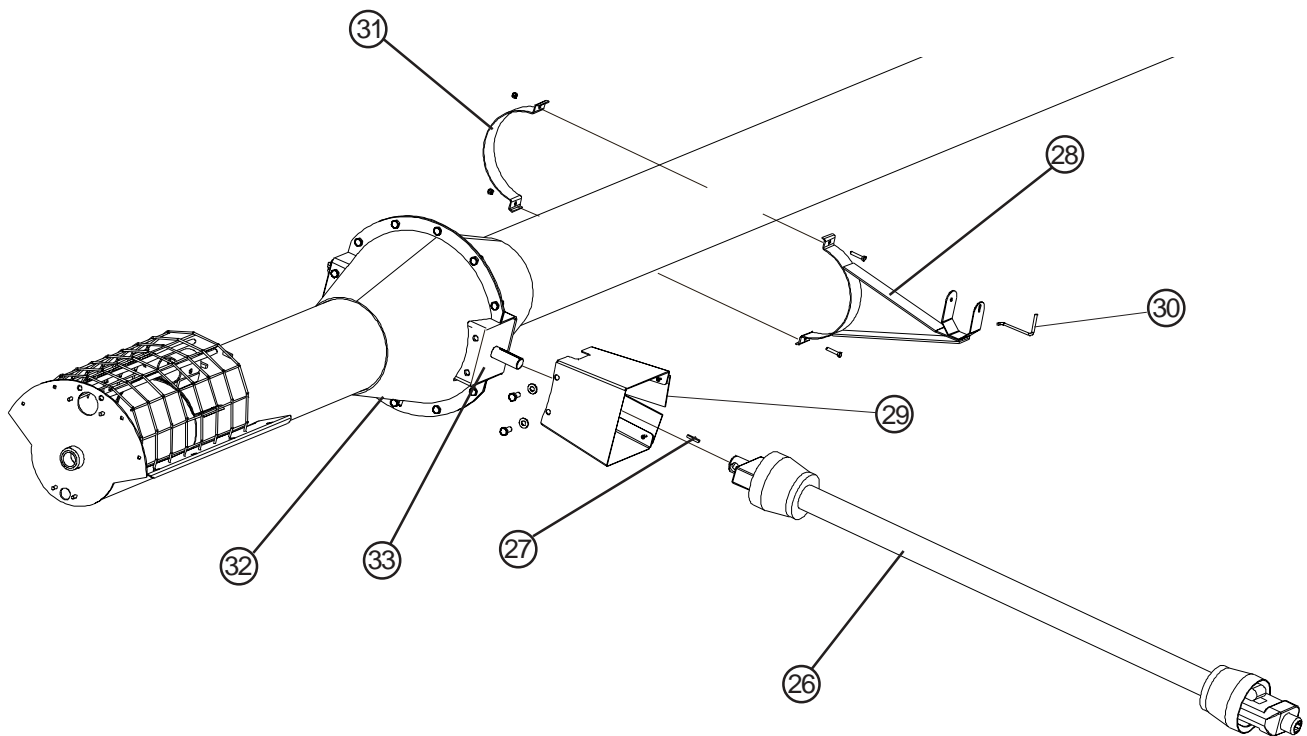

Electric Drive Components

Ref. No.	Part No.	Description
32	GK4061	Motor Mount Frame for 8" x 37', 42', 52', 62', & 72'
33	GK5096	Half Band for Motor Mount Frame
34	GK4131	Belt guard mount bracket
35	GK4118	Belt guard assembly
36	GK2544	Aluminum sheave 2B 1" bore for 8" x 32', 37', 42', 52'
	GK2545	Aluminum sheave 3B 1" bore for 8" x 62' & 72'
37	GK2016	Belt B-66
38	S-4513	Square Key 1/4" x 2"
39	GK2498	Gearbox 1:1
	GK2499	Gearbox 1.35:1

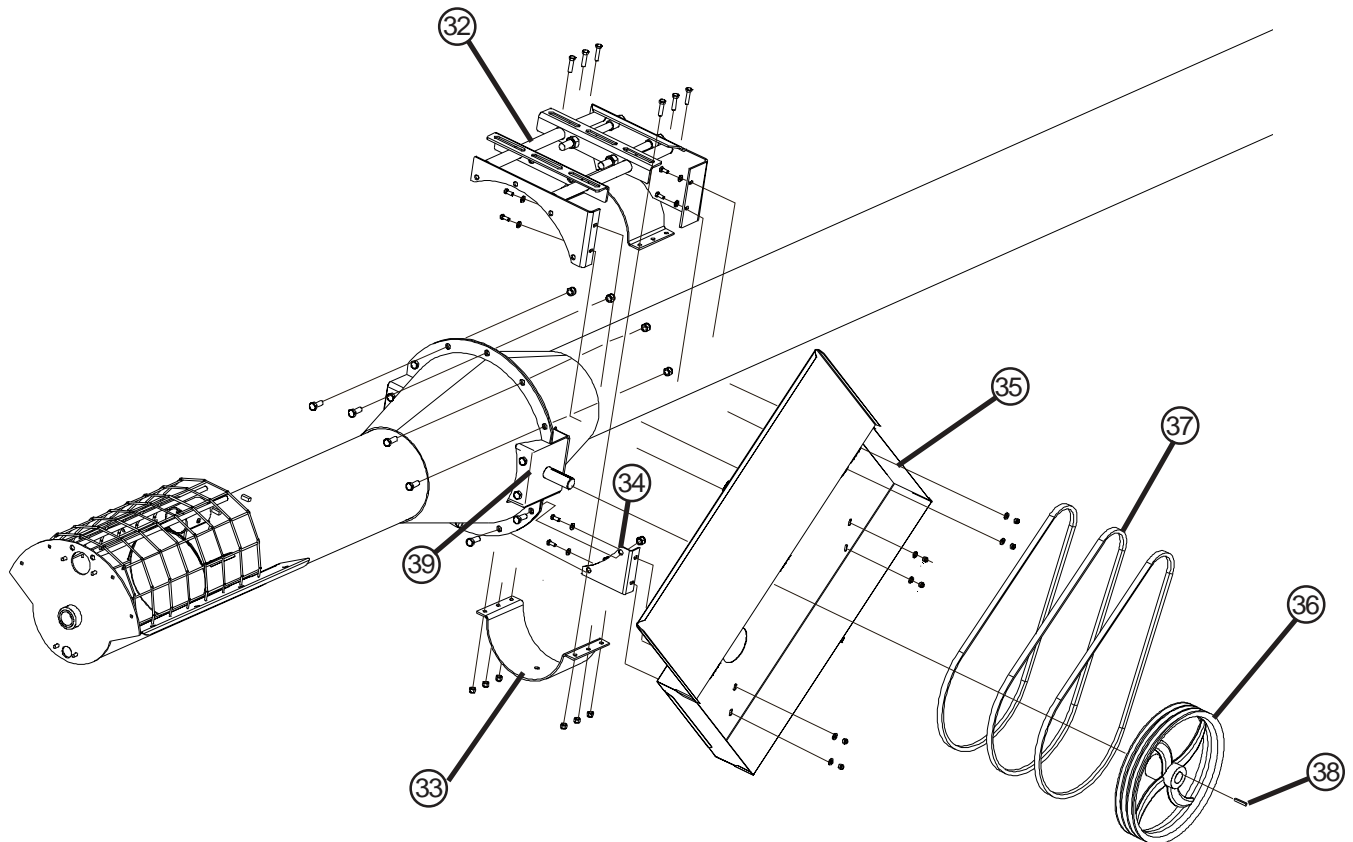

Spindle and Hub Assemblies

Ref No.	Description	4-bolt (1-5/8" x 10") for 8" x 32'	4-bolt (2-1/16" x 14") for 8" x 37', 42', 52', 62', and 72'
	Spindle and hub assembly	GK2705	GK1193
1	Spindle	GK1510	GK1511
2	Grease Seal	GK2703	GK2703
3	Inner cone	GK2700	GK2700
4	Inner cup	GK2711	GK2711
5	Hub	GK1572	GK1572
6	Outer cup	GK2712	GK2712
7	Outer cone	GK2701	GK2701
8	Lug bolt	GK2708	GK2708
9	Washer	GK2704	GK2704
10	Slotted hex nut	GK2702	GK2702
11	Cotter pin	GK2713	GK2713
12	Hub cup	GK1551	GK1551

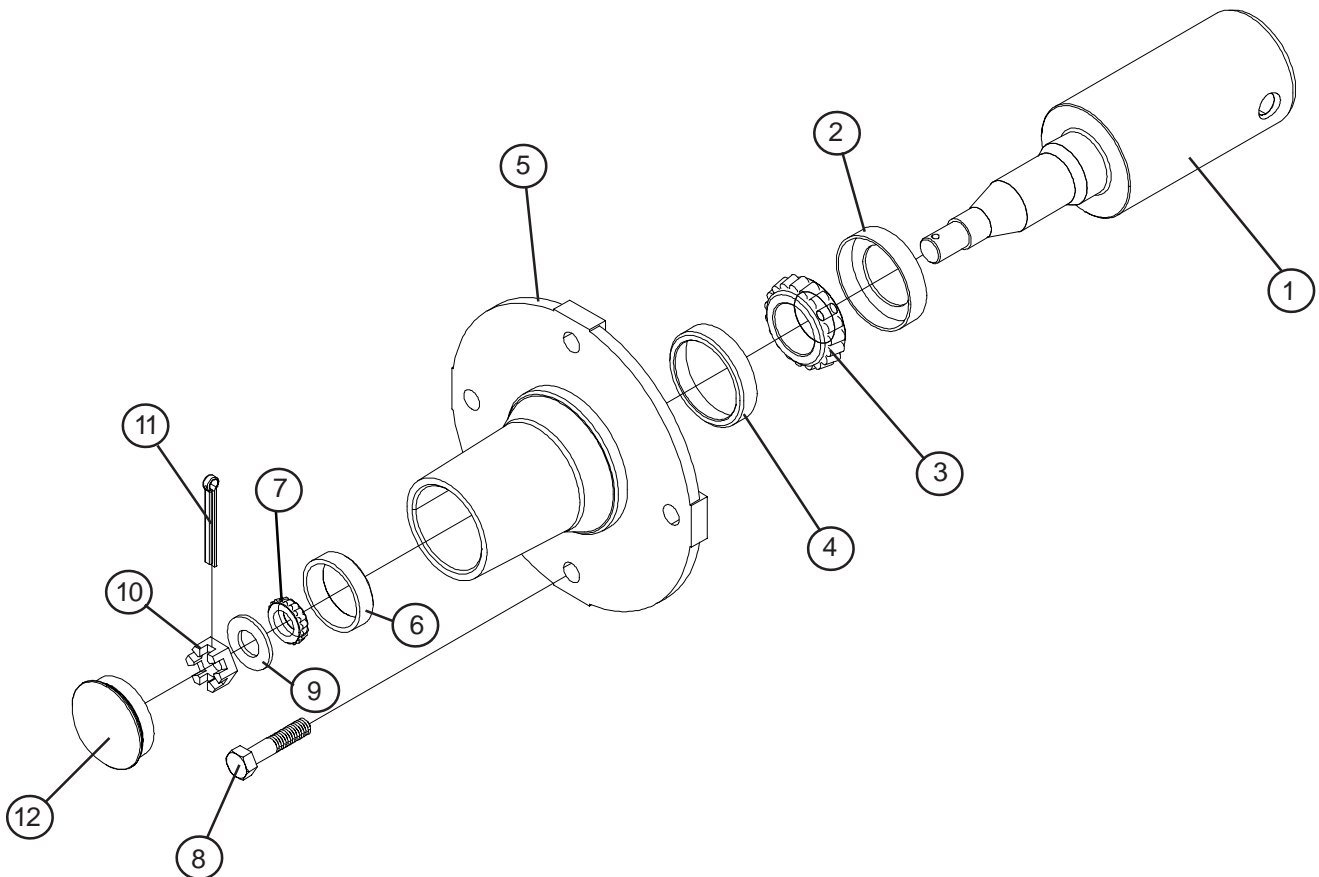

Winch - Brake Type 1000# GK1562

Item Number	Description	Qty. Req.	Part Number
1	1/4" - 20 x 1-1/2" Hex Screw	1	GK6225
2	1/4" Lockwasher	1	GK6226
3	1/4" Wide Flatwasher	1	GK6227
4	Handle Retainer Spacer	1	GK6228
5	Spring	1	GK6229
6	Handle	1	GK1567
7	Real Assembly	1	GK6231**
8	#10-24 Hex Nut	2	GK6232
9	Cable Keeper	1	GK1382
10	#10-24 x 5/8" Carriage Bolt	2	GK6234
11	Front Frame Spacer	1	GK6235**
12	3/8" Lockwasher	2	GK6236*
13	3/8" x 1/2" Reel Bolt	1	GK6237*
14	Back Frame Spacer	1	GK6238**
15	Pawl Spring	1	GK6239**
16	Pawl Spacer	1	GK6240**
17	Pawl	1	GK6241**
18	3/8" Flat Washer	1	GK6242*
19	3/8" x 5-1/2" Pawl Bolt	1	GK6243*
20	Frame	1	GK6244**
21	9/16" - 16 Locknut	1	GK6245*
22	Bearing	1	GK6246**
23	3/4" I.D. Bushing	2	GK6247**
24	9/16" Flat Washer	1	GK6248*
25	Pinion Gear	3	GK6249**
26	Pinion Shaft	1	GK6250**
27	Brake Backup Plate	1	GK6251**
28	Brake Pad	2	GK6252**
29	Ratchet	1	GK6253**
30	Cover	1	GK6254**
31	#10-32 x 1-1/2" Cover Screw	2	GK6255*

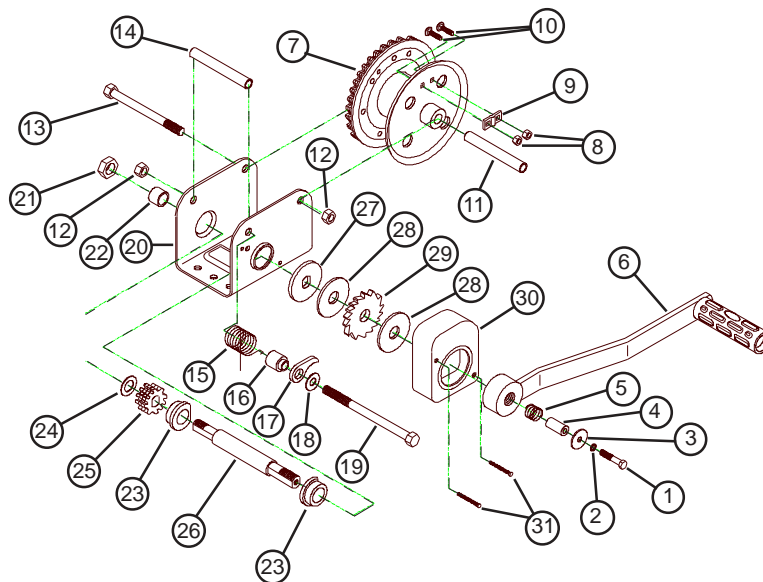

NOTE

* Indicates standard hardware items - purchase locally.

** these items are not available as separate parts because of the precision assembly required. If these parts require placement, a new winch must be purchased.

Winch - Brake Type 1500# GK3337

Item Number	Description	Qty. Req.	Part Number
1	1/4" - 20 x 1-1/2" Hex Screw	1	GK6225
2	1/4" Lockwasher	1	GK6226
3	1/4" Wide Flatwasher	1	GK6227
4	Handle Retainer Spacer	1	GK6228
5	Spring	1	GK6229
6	Handle	1	GK1567
7	Real Assembly	1	GK6259**
8	#10-24 Hex Nut	2	GK6232
9	Cable Keeper	1	GK1382
10	#10-24 x 5/8" Carriage Bolt	2	GK6234
11	Front Frame Spacer	1	GK6260**
12	3/8" Lockwasher	2	GK6141*
13	3/8" x 5" Reel Bolt	1	GK6261*
14	Back Frame Spacer	1	GK6262**
15	Pawl Spring	1	GK6239**
16	Pawl Spacer	1	GK6240**
17	Pawl	1	GK6241**
18	Washer	1	GK6248*
19	3/8" x 6" Pawl Bolt	1	GK6263*
20	Frame	1	GK6264**
21	9/16" - 18 Locknut	1	GK6245*
22	Bearing	1	GK6246**
23	Bushing	2	GK6247**
24	Washer	1	GK6248**
25	Pinion Gear	3	GK6249**
26	Pinion Shaft	1	GK6250**
27	Brake Backup Plate	1	GK6251**
28	Brake Pad	2	GK6252**
29	Ratchet	1	GK6253**
30	Cover	1	GK6254**
31	#10-32 x 1-1/2" Cover Screw	2	GK6255*

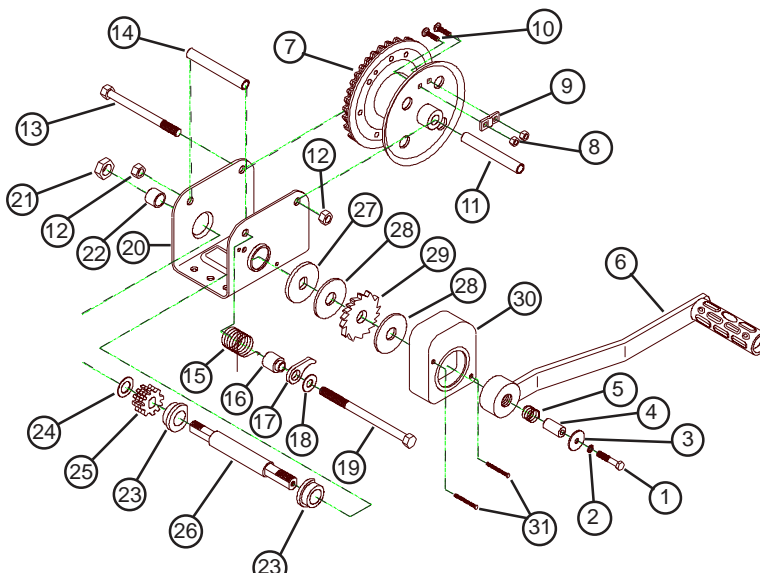

NOTE

* Indicates standard hardware items - purchase locally.
 ** these items are not available as separate parts because of the precision assembly required. If these parts require placement, a new winch must be purchased.

Winch - Brake Type 2500# GK2490

Item Number	Description	Qty. Req.	Part Number	Item Number	Description	Qty. Req.	Part Number
1	1/4" - 20 x 1-1/2" Hex Screw	1	GK6225	18	3/4" O.D. Bearing	2	GK6271**
2	1/4" Lockwasher	1	GK6226	19	3/4" I.D. Bushing	3	GK6272**
3	1/4" Wide Flatwasher	1	GK6227	20	1-1/2" I.D. Bushing	1	GK6273**
4	Handle Retainer Spacer	1	GK6228	21	1-1/2" O.D. Bushing	1	GK6274**
5	Spring	1	GK6229	22	Frame Spacer	1	GK6275**
6	Handle	1	GK1567	23	Frame	1	GK6276**
7	Reel Assembly	1	GK6266**	24	#10-32 Locknut	2	GK6277*
8	#10-24 Hex Nut	2	GK6232	25	Back Pinion Shaft	1	GK6278**
9	Cable Keeper	1	GK1382	26	Pawl Spring	1	GK6239**
10	#10-24 x 5/8" Carriage Bolt	2	GK6234	27	Pawl Spacer	1	GK6240**
11	3/8" Locknut	2	GK6236*	28	Pawl	1	GK6241**
12	Reel Bolt	1	GK6267*	29	Washer	1	GK6242*
13	9/16" Flat Washer	3	GK6268*	30	Pawl Bolt	1	GK6279*
14	Pinion Gear	8	GK6249**	31	Brake Backup Plate	2	GK6251*
15	Front Shaft	1	GK6269**	32	Brake Pad	2	GK6252*
16	Pick-Off Gear Assembly	1	GK6270**	33	Ratchet	1	GK6253**
17	9/16"-18 Locknut	3	GK6245*	34	Cover	1	GK6254**
				35	#10-32 x 1-3/4" Cover Screw	1	GK6280*

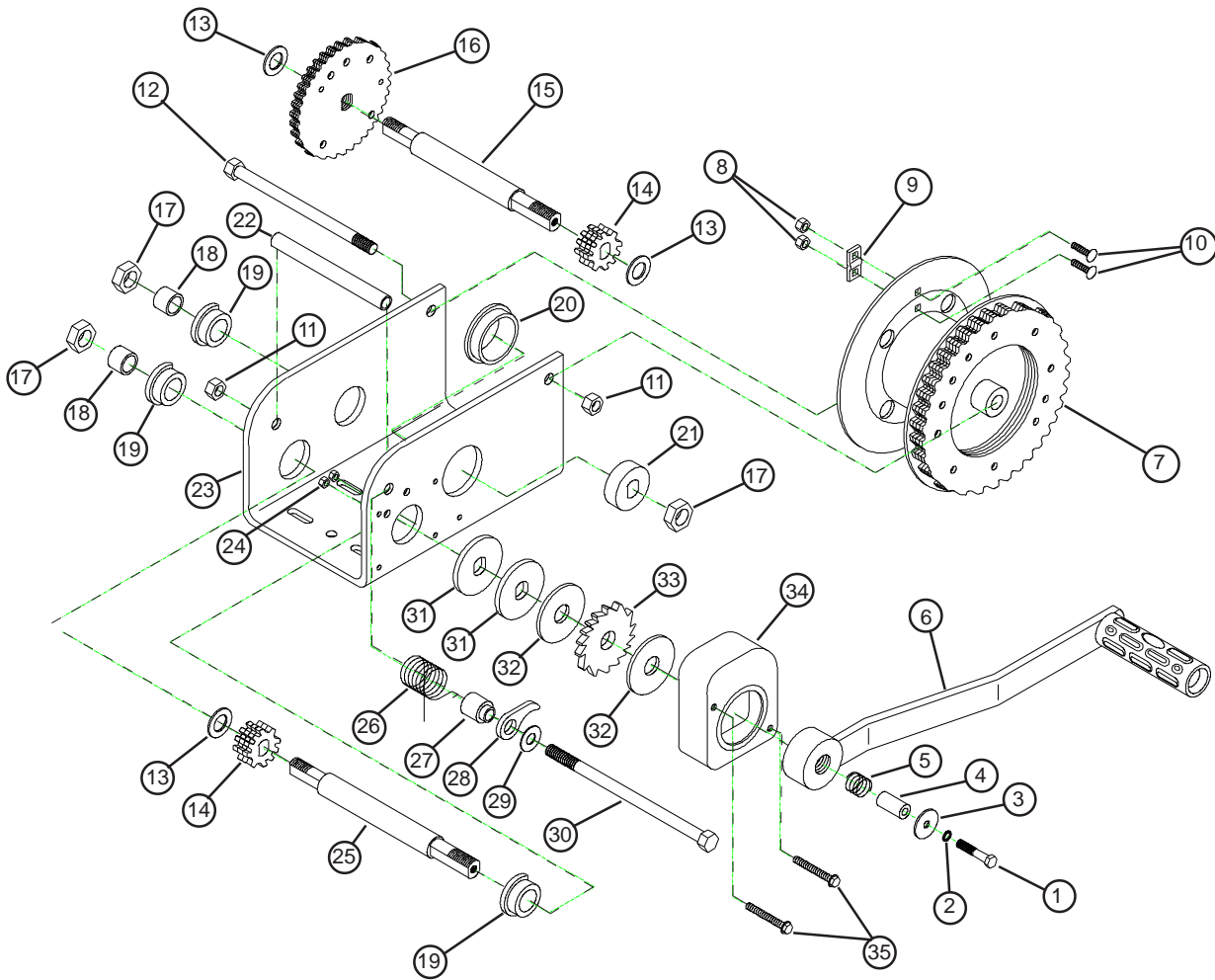

NOTE

* Indicates standard hardware items - purchase locally.
 ** these items are not available as separate parts because of the precision assembly required. If these parts require placement, a new winch must be purchased.

PTO Driveline GK1514

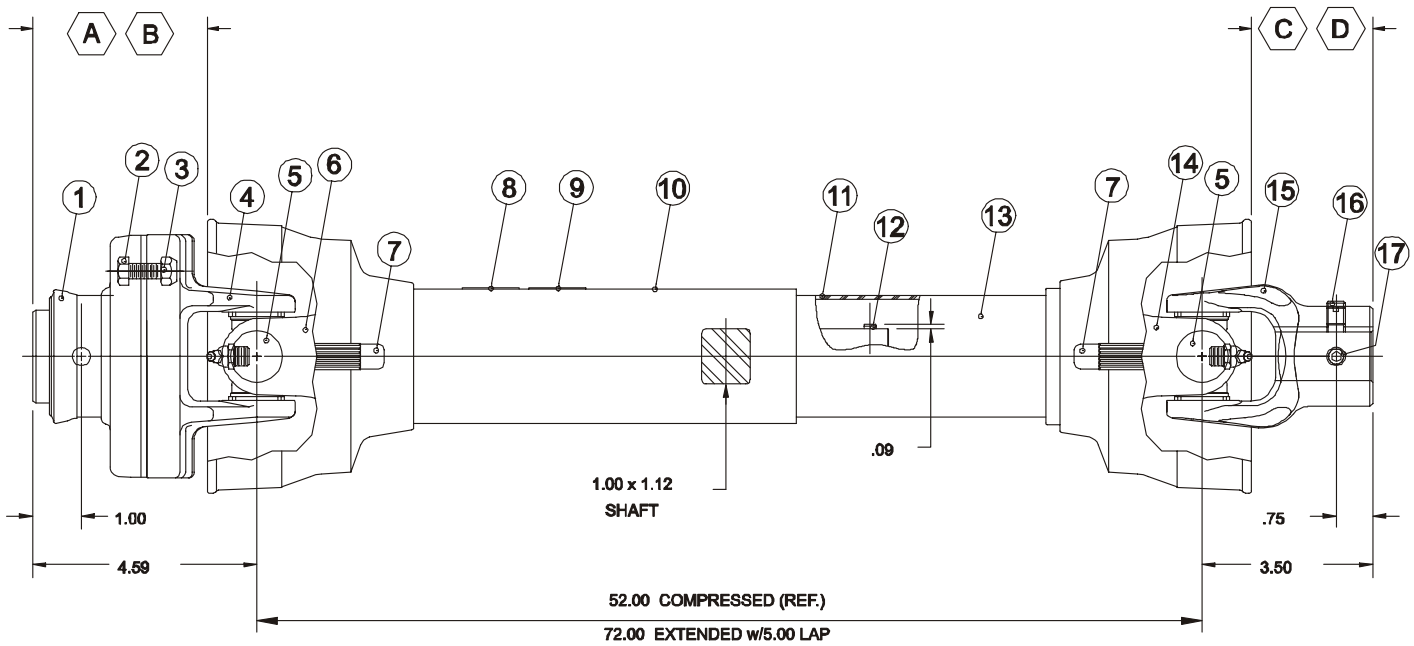

GK1514 - PTO Driveline		
Ref. No.	Part No.	Description
A	GK6026	Joint & Shaft Half Assembly with Guard
B	GK6298	Joint & Shaft Half Assembly
C	GK6025	Joint & Shaft Half Assembly with Guard
D	GK6299	Joint & Shaft Half Assembly
1	GK2665	Spring-Lok Repair Kit
2	GK2657	4/16"-18 x 1" Bolt Grade 5
3	GK6302	5/16"-18 Nut
4	GK2675	Ball Shear Assembly
5	GK2654	12R Cross & Bearing Kit
6	GK6300	Yoke & Shaft
7	GK2664	Nylon Repair Kit (Not Shown)
8	GK2658	Safety Sign
9	GK6303	Safety Sign 540 RPM
10	GK2689	Outer Guard
11	GK2684	Inner guard
12	GKS-6079	Roll Pin
13	GK2659	Safety Sign (Not Shown)
14	GK6301	Yoke , Tube, & Slip Sleeve
15	GK2677	Yoke
16	GK2655	Set Screw 3/8"-16 x 3/8" Long Knurled Cup Point
17	GK3289	Set Screw 3/8"-16 x 1/2" Long Knurled Cup Point

NOTE Shear Bolt Replacement Kit No. GK1584 includes six (6) 3/8" - 16 x 1" long Grade 2 hex head bolts and locknuts. Shear Bolt Replacement Kit No. GK3099 includes six (6) 3/8" - 16 x 1" long Grade 5 hex head bolts and locknuts.

Hydraulic Cylinder GK1527 & GK1528

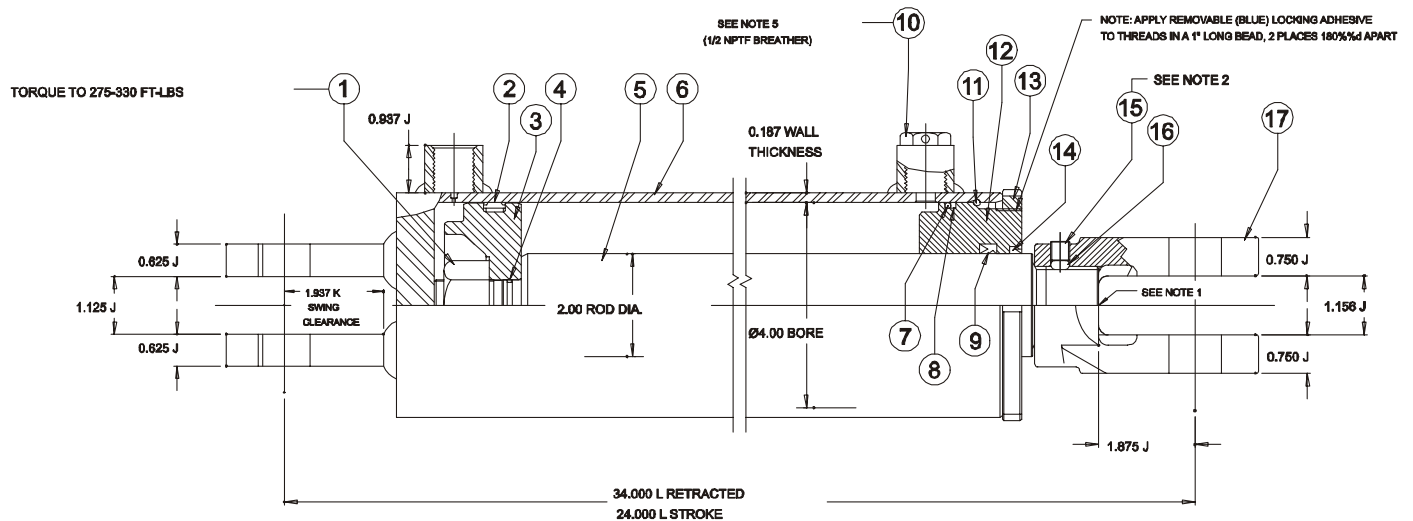

Ref #	Complete No. GK1527 4" Bore x 24" Stroke Used on 8" x 52' & 62'	Complete No. GK1528 4" Bore x 36" Stroke Used on 8" x 72'	Description
1	GK6213	GK6213	Nut Lock
2	GK6356	GK6356	O-Ring Seal
3	GK6211	GK6211	Piston Rod 4" O.D.
4	GK6357	GK6357	Small O-Ring
5	GK6208	GK6222	Piston Rod 2" DX
6	GK6207	GK6221	Cylinder 4" I.D.
7	GK6355	GK6355	Large O-Ring
8	GK6358	GK6358	Backup Washer
9	GK6360	GK6360	Backup Washer
10	GK6216	GK6216	Breather Plug 1/2" NPT
11	GK6214	GK6214	Cylinder: Ret Ring Rod Int 4"
12	GK6210	GK6210	Cylinder Guide 4" I.D. x 2"
13	GK6219	GK6219	Spanner Nut 3/4" x 4-1/2" O.D.
14	GK6359	GK6359	Piston Rod Washer
15	GK6220	GK6220	Set Screw 3/8"-16 x 3/4"
16	GK6212	GK6212	Plug: Nylon
17	GK6209	GK6209	Clevis Rod 1-1/2"-12UNF
N/S	GK1531	GK1531	Clevis Pin & Clip
N/S	GK6217	GK6217	Plug Steel Pipe, 1/2" HS
N/S	GK6218	GK6218	Cylinder
N/S	GK3323	GK3323	Seal Kit 4" Bore

NOTE * Only available as part of a seal kit.

GEARBOX GK2498

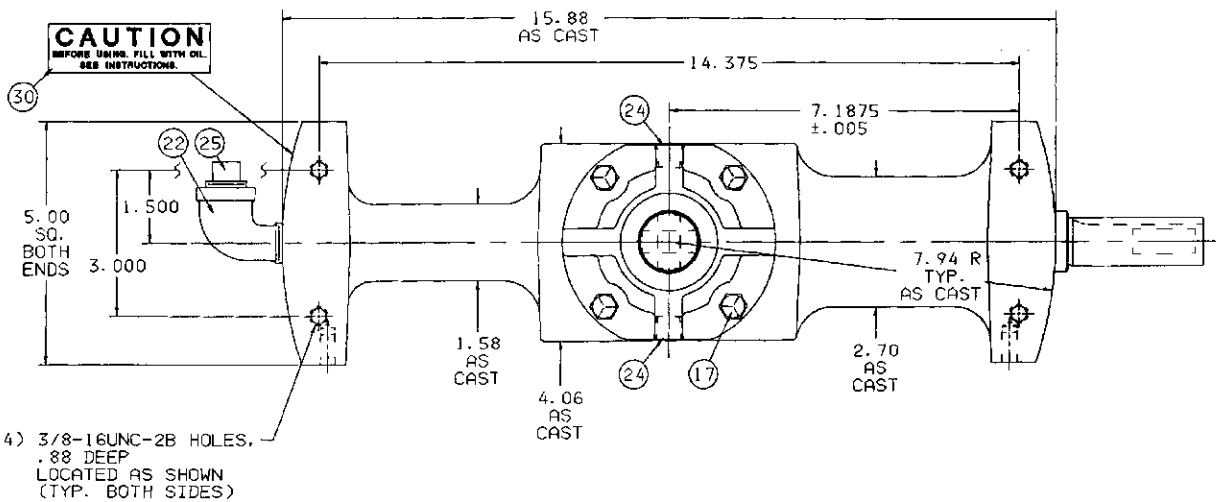
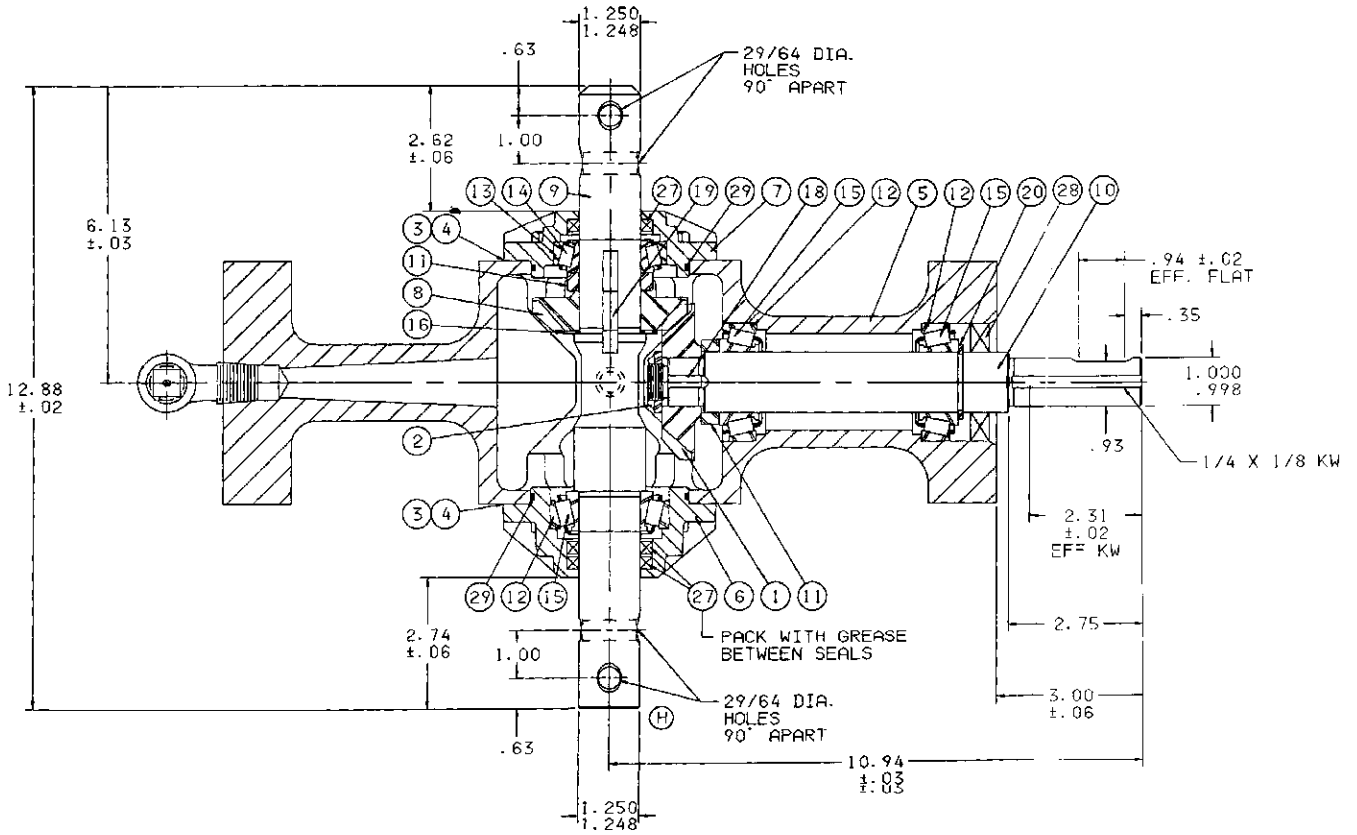

GK2498 - GEARBOX		
Ref. No.	Part No.	Description
	GK2498	Complete Assembly
1	GK6123	Gear, St Bev 25T
2	GK6122	Nut, Lock 3/4" NF
3	GK3215	Shim .005
4	GK6099	Shim .002
5	GK6108	Housing
6	GK2600	Cap
7	GK2601	Cap
8	GK6124	Gear, St Bev 25T
9	GK2599	Shaft, Cross
10	GK2598	Shaft, Pinion
11	GK6117	Spacer
12	GK5438	Bearing Cup
13	GK2711	Bearing Cup - LM67010
14	GK2700	Bearing Cone - LM67048
15	GK5466	Bearing Cone
16	GK6126	Race, Thrust
17	GK6038	Hex Head Capscrew (Grade 5)
18	GK6125	Key 1/4" Sq. x 11/16
19	GK6121	Key 5/16 x 1/4 x 13/16
20	GK6058	Retaining ring
22	GK6109	Street Elbow
24	GK5454	Pipe Socket plug
25	GK5475	Breather 1/2 NPT
27	GK6110	Seal - 12364
28	GK5469	Seal - 122443TB
29	GK6116	O-Ring
30	GK6104	Label "Caution"

THE COMPANY WARRANTS ALL PRODUCTS MANUFACTURED TO BE FREE OF DEFECTS IN MATERIAL AND WORKMANSHIP UNDER NORMAL USAGE AND CONDITIONS FOR A PERIOD OF TWELVE (12) MONTHS AFTER RETAIL SALE TO THE ORIGINAL END USER OF SUCH PRODUCTS. OUR ONLY OBLIGATION IS, AND PURCHASER'S SOLE REMEDY SHALL BE TO REPAIR OR REPLACE, AT THE COMPANY'S OPTION AND EXPENSE, PRODUCTS THAT, IN THE MANUFACTURER'S SOLE JUDGEMENT, CONTAIN A MATERIAL DEFECT DUE TO MATERIALS OR WORKMANSHIP. ALL DELIVERY AND SHIPMENT CHARGES TO AND FROM THE FACTORY WILL BE PURCHASER'S RESPONSIBILITY. EXPENSES INCURRED BY OR ON BEHALF OF THE PURCHASER WITHOUT PRIOR WRITTEN AUTHORIZATION FROM AN AUTHORIZED EMPLOYEE OF THE COMPANY SHALL BE THE SOLE RESPONSIBILITY OF THE PURCHASER.

EXCEPT FOR THE ABOVE EXPRESS LIMITED WARRANTIES, THE COMPANY MAKES NO WARRANTY OF ANY KIND, EXPRESSED OR IMPLIED, INCLUDING, WITHOUT LIMITATION, WARRANTIES OF MERCHANTABILITY OR FITNESS FOR A PARTICULAR PURPOSE OR USE IN CONNECTION WITH (i) PRODUCT MANUFACTURED OR SOLD BY THE COMPANY OR (ii) ANY ADVICE, INSTRUCTION, RECOMMENDATION OR SUGGESTION PROVIDED BY AN AGENT, REPRESENTATIVE OR EMPLOYEE OF THE COMPANY REGARDING OR RELATED TO THE CONFIGURATION, INSTALLATION, LAYOUT, SUITABILITY FOR A PARTICULAR PURPOSE, OR DESIGN OF SUCH PRODUCT OR PRODUCTS.

IN NO EVENT SHALL THE COMPANY BE LIABLE FOR ANY DIRECT, INDIRECT, INCIDENTAL, OR CONSEQUENTIAL DAMAGES, INCLUDING, WITHOUT LIMITATION, LOSS OF ANTICIPATED PROFITS OR BENEFITS. PURCHASER'S SOLE AND EXCLUSIVE REMEDY SHALL BE LIMITED TO THAT STATED ABOVE, WHICH SHALL NOT EXCEED THE AMOUNT PAID FOR THE PRODUCT PURCHASED. THIS WARRANTY IS NOT TRANSFERABLE AND APPLIES ONLY TO THE ORIGINAL PURCHASER. WE SHALL HAVE NO OBLIGATION OR RESPONSIBILITY FOR ANY REPRESENTATIVE OR WARRANTIES MADE BY OR ON BEHALF OF ANY DEALER, AGENT OR DISTRIBUTOR OF THE COMPANY.

THE COMPANY ASSUMES NO RESPONSIBILITY FOR FIELD MODIFICATIONS. MODIFICATIONS TO THE PRODUCT NOT SPECIFICALLY COVERED BY THE CONTENTS OF THIS MANUAL WILL NULLIFY ANY PRODUCT WARRANTY THAT MIGHT HAVE BEEN OTHERWISE AVAILABLE. THE USE OF OUR EQUIPMENT TO HANDLE MATERIALS OTHER THAN FREE FLOWING, NONABRASIVE AND DRY MATERIALS, AS INTENDED, WILL RESULT IN THE VOIDING OF THIS LIMITED WARRANTY.

THE FOREGOING WARRANTY SHALL NOT COVER PRODUCTS OR PARTS WHICH HAVE BEEN DAMAGED BY NEGLIGENT USE, MISUSE, ALTERATION, OR ACCIDENT. ANY NEGLIGENT USE, MISUSE, ALTERATION, OR DAMAGE DUE TO ACCIDENT, AS DETERMINED BY A COMPANY REPRESENTATIVE, MAY VOID THE WARRANTY. THIS WARRANTY COVERS ONLY PRODUCTS MANUFACTURED BY THE COMPANY. THIS WARRANTY IS EXCLUSIVE AND IN LIEU OF ALL OTHER WARRANTIES EXPRESS OR IMPLIED. WE RESERVE THE RIGHT TO MAKE DESIGN OR SPECIFICATION CHANGES AT ANY TIME, BEARING NO RESPONSIBILITY TO MAKE SIMILAR DESIGN OR SPECIFICATION CHANGES ON PREVIOUSLY SOLD MERCHANDISE.

PRIOR TO INSTALLATION, PURCHASER HAS THE RESPONSIBILITY TO RESEARCH AND COMPLY WITH ALL FEDERAL, STATE, AND LOCAL CODES WHICH MAY APPLY TO THE LOCATION AND INSTALLATION.

This Equipment shall be installed in accordance with the current installation codes and applicable regulations which should be carefully followed in all cases. Authorities having jurisdiction should be consulted before installation occurs.

== GRAIN KING ==

**1004 East Illinois Street
Assumption, IL 62510
Phone: 217-226-4421**
