

Deluxe Vane Axial Heater

MODEL # VH __ - __ __ - __ __ - D (HIGH FIRE)

MODEL # VL __ - __ __ - __ __ - D (LOW FIRE)

Owner's Manual

MANUAL # PNEG-012



a division of
THE GSI GROUP

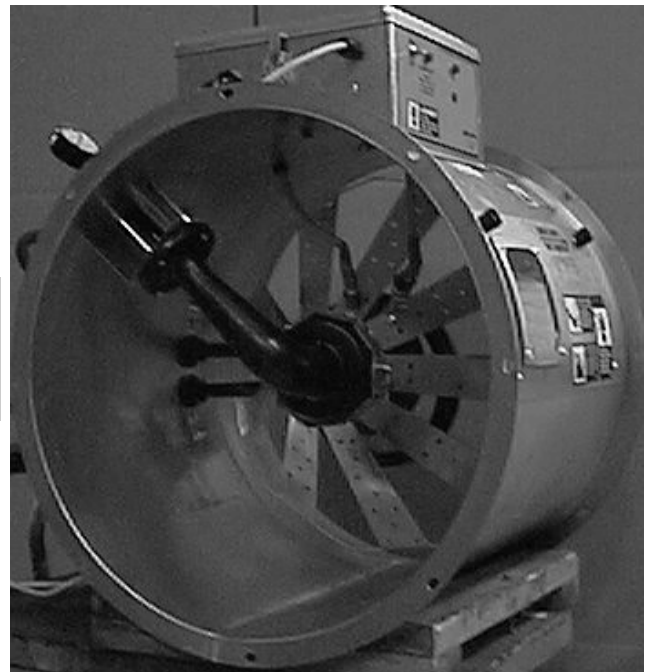

✓OK

- _____ 1. All wire connections
- _____ 2. Spark plug gap .125
- _____ 3. Pipetrain tightness and gas leaks
- _____ 4. Flame sensor tight
- _____ 5. Fuse in place, extra fuse provided
- _____ 6. Time delay reset
- _____ 7. Indicator light
- _____ 8. Pressure gauge
- _____ 9. Regulator adjusted
- _____ 10. Shut off valve operates correctly
- _____ 11. Vapor high limit
- _____ 12. Unit cycles on to off
- _____ 13. Heat rise even across transition
- _____ 14. Unit cycles hi to lo (hi-lo only)
- _____ 15. Mod valve holds temperature within 1 degree
(mod units only).
- _____ 16. All decals and serial number tag
- _____ 17. Aesthetic appearance
- _____ 18. Manual

Tester Signature _____

Date _____

Roof Warning, Operation & Safety.....4
Warning and Disclaimer.....5
Safety Alert Decals.....6
Standard Vane Axial Heater Installation.....10
 Fuel Connection.....10
 Heater Electrical Installation.....11
 Plenum Thermostat Mounting.....12
 Transition Hi-Limit Installation.....12
 Second Heater Installation.....13
 Temperature Heater Specifications.....14
Standard Vane Axial Heater Operation.....15
 Standard Heater Operation.....15
 Hi-Lo Heater Operation.....16
 BTU's Per Gauge Pressure (PSI) Propane Models (Approximate).....16
 BTU's Per Gauge Pressure (PSI) Natural Gas Models (Approximate).....17
 Adjusting The Vaporizer.....18
 Modulating Valve Operation.....19
Wiring Schematic.....20
Heater Parts.....21
 18" Gas Heater.....22
 24" & 26" Gas Heater.....24
 28" Gas Heater.....26
 Control Box.....28
 Axial Propane Vapor Pipetrain.....30
 Axial Natural Gas Pipetrain.....32
 Axial Propane Vapor Hi-Lo Pipetrain.....34
 Axial Natural Gas Hi-Lo Pipetrain.....36
 Axial LP Pipetrain.....38
Notes.....40
Warranty.....41



GSI DOES NOT WARRANT ANY ROOF DAMAGE CAUSED BY EXCESSIVE VACUUM OR INTERNAL PRESSURE FROM FANS OR OTHER AIR MOVING SYSTEMS. ADEQUATE VENTILATION AND/OR "MAKEUP AIR" DEVICES SHOULD BE PROVIDED FOR ALL POWERED AIR HANDLING SYSTEMS. GSI DOES NOT RECOMMEND THE USE OF DOWNWARD FLOW SYSTEMS (SUCTION). SEVERE ROOF DAMAGE CAN RESULT FROM ANY BLOCKAGE OF AIR PASSAGES. RUNNING FANS DURING HIGH HUMIDITY/COLD WEATHER CONDITIONS CAN CAUSE AIR EXHAUST OR INTAKE PORTS TO FREEZE.

Heater Operation

Thank you for choosing a GSI product. It is designed to give excellent performance and service for many years.

This manual describes the operation of the GSI Deluxe Vane Axial Heater. Many models are available to accommodate low, medium or high temperature grain conditioning.

The principal concern of The GSI Group Inc. (GSI) is your safety and the safety of others associated with grain handling equipment. This manual is written to help you understand safe operating

procedures, and some of the problems that may be encountered by the operator or other personnel.

As owner and/or operator, it is your responsibility to know what requirements, hazards and precautions exist, and to inform all personnel associated with the equipment, or who are in the heater area. Avoid any alterations to the equipment. Such alterations may produce a very dangerous situation, where serious injury or death may occur.

Safety Alert Symbol

The symbol shown is used to call your attention to instructions concerning your personal safety. Watch for this symbol; it points out important safety precautions. It means "ATTENTION", "WARNING", "CAUTION", and "DANGER". Read the message and be cautious to the possibility of personal injury or death.



Warning! Be Alert!

Personnel operating or working around electric fans should read this manual. This manual must be delivered with the equipment to its owner. Failure to read this manual and its safety instructions is a misuse of the equipment.



Fuel Warning

Important! Do not use propane tanks which have previously been used for ammonia unless they have been purged according to procedures of the National L. P. Association.

Be sure fuel supply system complies with all local codes for L. P. gas installations. **DO NOT USE FLAME FOR LEAK TESTING.**

Power Warning

Be sure power is disconnected and locked out before installation! Failure to do so may cause serious injury or death.

Important! Heater must be interlocked with fan for safe operation.

Important! Thermostat must be installed for safe operation.

Proper Use of Product

This product is intended for the use of grain drying only! Any other use is a misuse of this product.

This product has sharp edges! These sharp edges may cause serious injury. To avoid injury handle sharp edges with caution and use proper protective clothing and equipment at all times.

Guards are removed for illustration only. All guards must be in place before and during operation.

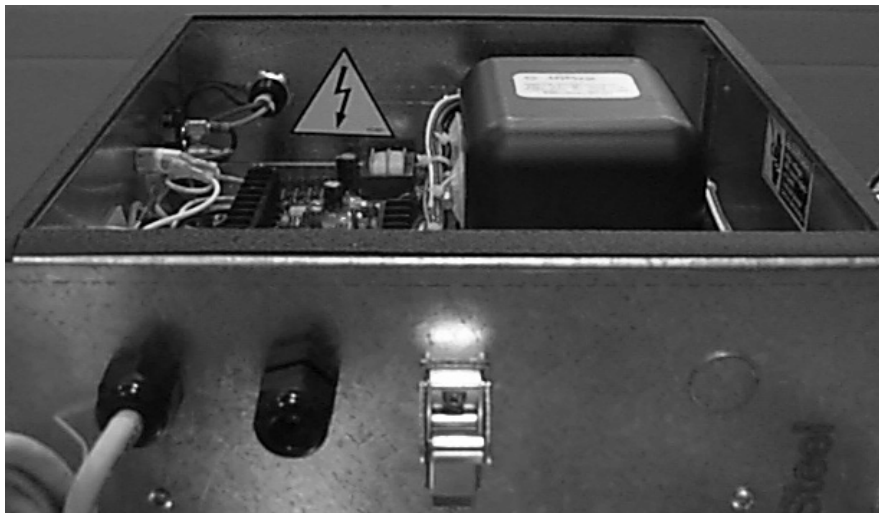

The GSI Group Inc. recommends contacting your local power company, and having a representative survey your installation so the wiring is compatible with their system, and adequate power is supplied to your unit.

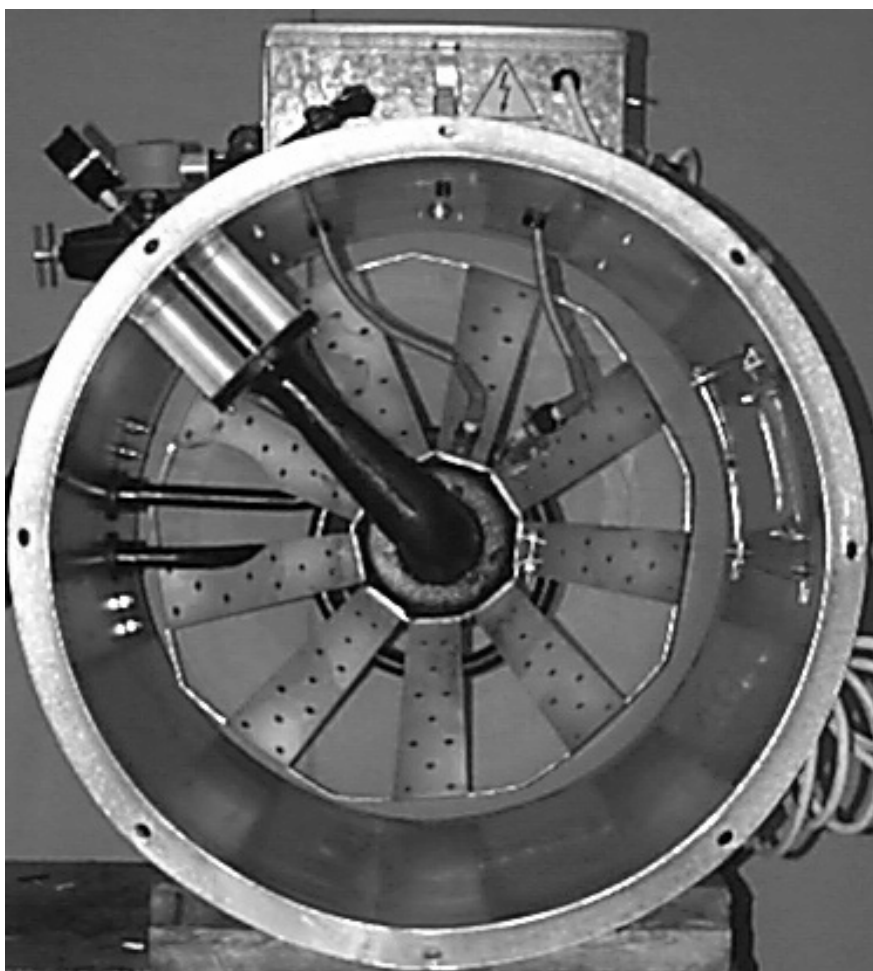

Safety decals should be read and understood by all people in the grain handling area. The bottom-right decal warns that the enclosure contains electrical devices carrying high voltages that will cause injury or death. Lockout power before servicing.

If a decal is damaged or is missing contact:

The GSI Group Inc.
1004 E. Illinois St.
Assumption, IL 62510
217-226-4421

A free replacement will be sent to you.

Safety Alert Decals for Door



⚠ WARNING
Stay clear of rotating blade. Blade could start automatically. Can cause serious injury. Disconnect power before servicing.
DC-1225



⚠ WARNING
Flame and pressure beyond door. Do not operate with service door removed. Keep head and hands clear. Can cause serious injury.
DC-1227



⚠ DANGER!
High voltage. Will cause serious injury or death. Lockout power before servicing.
DC-1224



Safety Decals for Bin

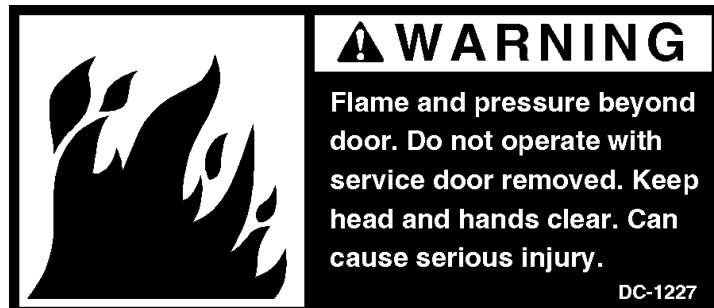

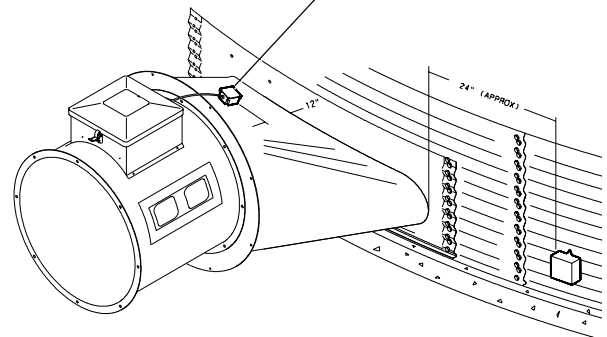
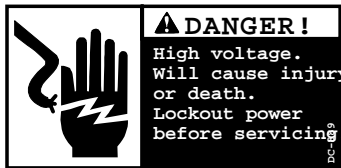
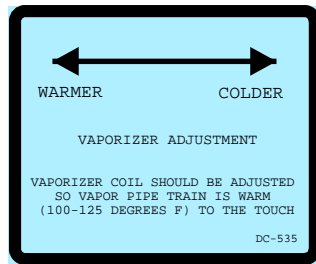

Fuel Connection



Important! Do not use propane tanks which have previously been used for ammonia unless they have been purged according to procedures of the National L. P. Association.

Be sure fuel supply system complies with all local codes for L. P. gas installations. **DO NOT USE FLAME FOR LEAK TESTING.**

Liquid Propane Models

1. LP models are designed to run on liquid propane, with liquid draw from the propane tank. Avoid using propane supply tanks that have been used for vapor draw for long periods of time. When using liquid draw systems any moisture that may be present in tank or lines may freeze when system is used in cold weather. To avoid this, the usual precaution is to purge the system with methanol.
2. Run proper size line (see specifications on page 14) to liquid pipetrain on heater. Have a qualified gas service man inspect installation to be sure that everything is installed according to local codes and ordinances.
3. After installation is complete check all connections for leaks with liquid detergent or comparable. Wear rubber gloves and eye protection. Avoid contact with liquid propane. **DO NOT USE FLAME FOR LEAK TESTING.**

Propane Vapor Models

1. Propane vapor models are designed to run directly off of supply tank or from a separate external vaporizer.

2. Run proper size line (see specifications on page 14) to pipetrain on heater. Have a qualified gas service person inspect installation to be sure everything is installed according to local codes and ordinances.
3. After installation is complete check all connections for leaks. **DO NOT USE FLAME FOR LEAK TESTING.**

Natural Gas Models

1. Natural gas models are similar to vapor models, but have a larger orifice to accommodate lower pressure sometimes found with natural gas.
2. Run proper size line (see specifications on page 14) to pipetrain on heater. Have a qualified gas service man inspect installation to be sure everything is installed according to local codes and ordinances.
3. After installation is complete check all connections for leaks. **DO NOT USE FLAME FOR LEAK TESTING.**

Heater Electrical Installation (230V Fans)

THESE INSTRUCTIONS ARE FOR HEATER INSTALLATION ON FAN UNITS WITH 230V MOTORS.



BE SURE POWER IS DISCONNECTED AND LOCKED OUT BEFORE INSTALLATION! FAILURE TO DO SO MAY CAUSE SERIOUS INJURY OR DEATH.

1. Connect power cord to fan control box.
2. Make field connection of wires in fan box as shown in Figure 2. 110V power supply or .5KVA 460V to 110V transformer must be used to supply power for heater. **IMPORTANT! HEATER MUST BE INTERLOCKED WITH FAN FOR SAFE OPERATION.**
3. Connect deluxe thermostat control (optional) as shown in Figure 2. **IMPORTANT! THERMOSTAT MUST BE INSTALLED FOR SAFE OPERATION.**

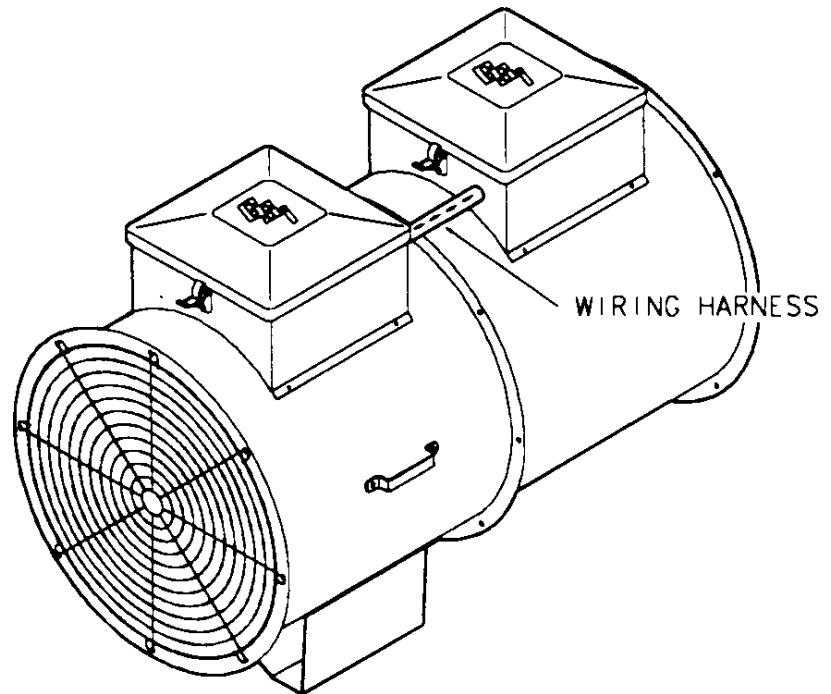

Figure 1: Illustration of deluxe vane axial heater wiring installation on a fan unit.

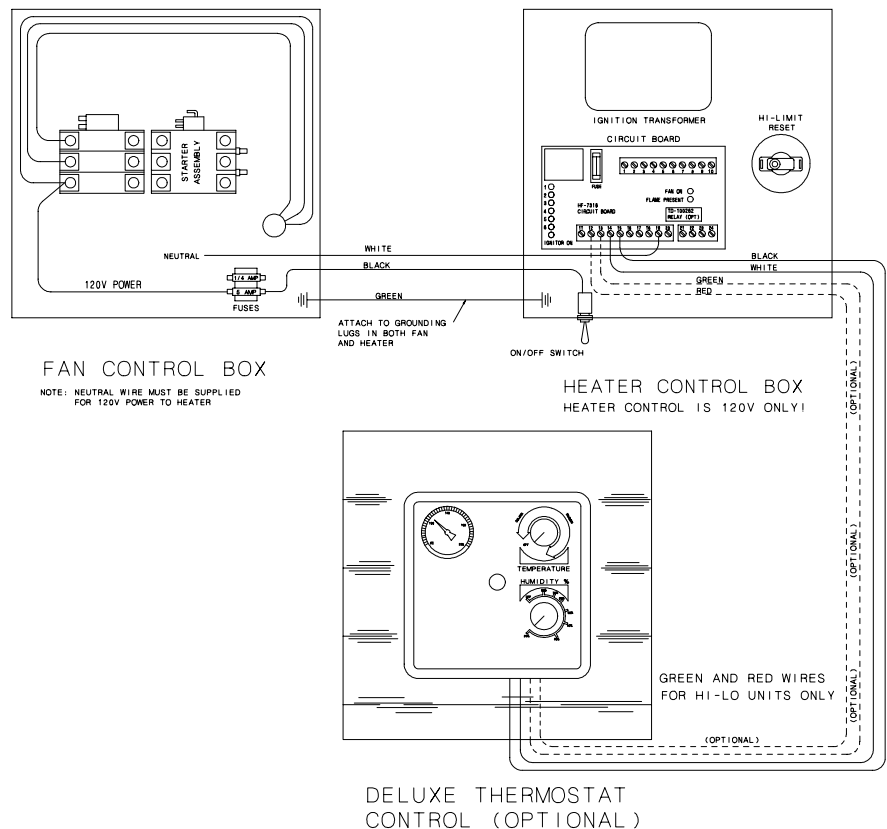
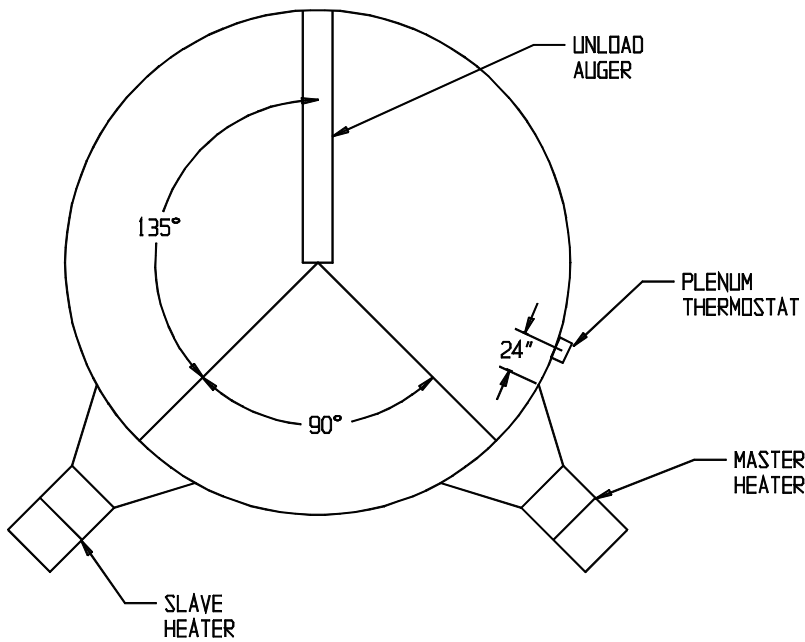

Figure 2: Deluxe vane axial heater wiring to fan unit.

Bin Configuration



IMPORTANT! When mounting (2) heaters on a bin it is imperative that they be situated as in above drawing. Plenum thermostat must be to the right of master heater and master heater must be to the right of slave heater.

Transition Hi-limit Installation

1. Mark location on transition one (1) foot up from the bottom (entrance collar) and centered in the transition.
2. Drill or knock out 7/8" diameter hole on marked location.
3. Install transition hi-limit using supplied self drilling screws.

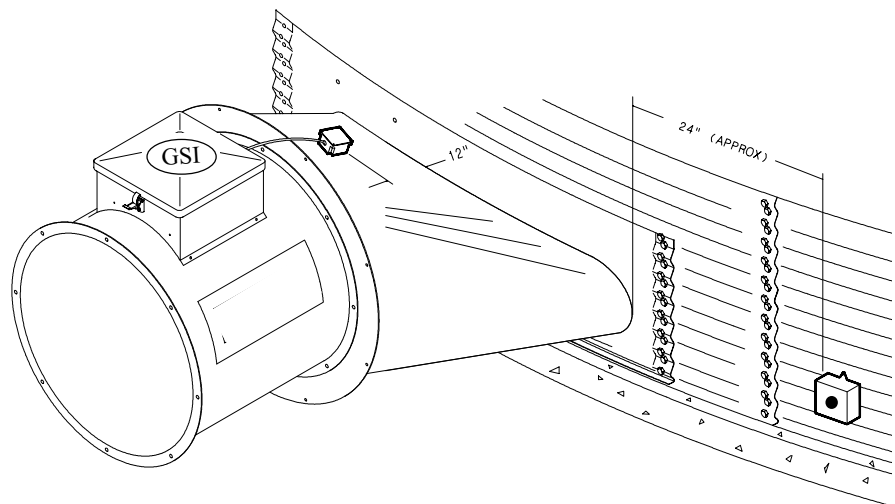
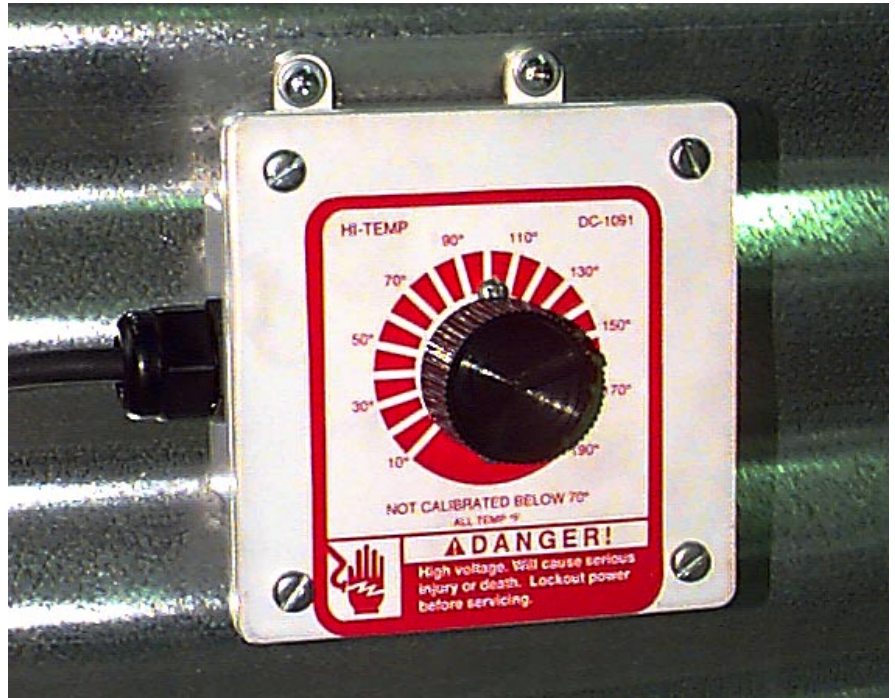

Figure 3: The transition connecting the Vane Axial Heater to the bin with the plenum sensor in place.

Plenum Thermostat Mounting

The plenum thermostat is the 4 x 4 white box with knob that is preconnected to heater when heater is ordered with thermostat.

1. 24" to the right side of the transition, drill one $\frac{3}{8}$ " hole (high temp) or 1 $\frac{1}{2}$ " hole (low temp) in the center of the plenum in a valley (4.00" corrugation) or hill (2.66" corrugation) on bin sidewall.
2. Insert the probe through the hole.
3. Position the housing so that the tabs are vertical, and the cord exits the housing horizontally.



Plenum thermostat mounting on bin wall.

4. Use 4 self drilling screws to mount the housing to the bin sidewall.
5. Caulk between the housing and the sidewall to seal.

THIS TABLE IS NOT INTENDED AS A DRYING GUIDE. IT SHOULD BE USED AS A REFERENCE FOR SETTING MAXIMUM PLENUM TEMPERATURE FOR SAFE OPERATION.

Operating Temperature Table

	LO-TEMP BATCH	HIGH-TEMP BATCH DRY NO STIRRING	HIGH-TEMP WITH STIRRING	CONTINUOUS FLOW (RECIRCULATING)
CORN	5-20° ABOVE AMBIENT TEMP	120°	140°	160°
RICE	5-10° ABOVE AMBIENT TEMP	100°	100°	NOT RECOMMENDED
BEANS & WHEAT	5-20° ABOVE AMBIENT TEMP	110°	120°	NOT RECOMMENDED

**IMPORTANT!
DO NOT EXCEED
PLENUM
TEMPERATURES
LISTED IN TABLE**

For Units Using HF-7318 Control Board

2 Deluxe heaters may be connected to one grain drying system and wired so they cycle together. One of the heaters should have a thermostat connected to it as per the installation instructions. That heater will be referred to as the master. The other heater (without the thermostat) will be referred to as the slave.

Installation For Standard Units

1. Install relay base (TD-100283) in master heater control box.
2. Connect wire between term 6 on circuit board and terminals 14 on relay base in master heater.
3. Connect wire between term 13 on relay base and terminals 8 on circuit board in master heater.
4. Run 2 wires (18 gage) between master and slave heaters.

5. Connect wires to terminal 5 and 9 (points A and B) on relay base in master heater.
6. Connect wire from terminal 9 in master to terminal 14 (point F) in slave unit.
7. Connect wire from terminal 5 in master to terminal 15 (point E) in slave unit.
8. Install relay (TD-100282) in relay base.

Additional Steps For Hi-Lo Units

1. Run 2 wires (18 gage) between master and slave unit.
2. Connect wires to terminals 21 and 22 (points C and D) on circuit board in main heater.
3. Connect wire from terminal 21 in master to terminal 12 (point H) in slave unit.
4. Connect wire from terminal 22 in master to terminal 13 (point G) in slave unit.
5. Install relay (TD-100282) in relay base.

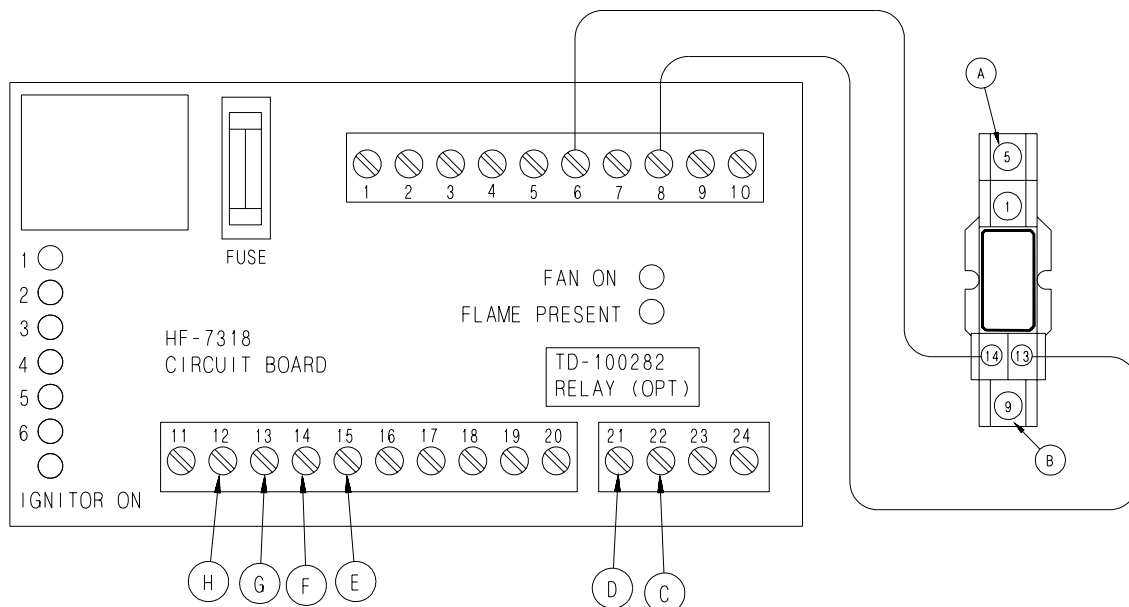

Figure 4: The HF-7318 control board.

High Temperature Heater Specifications

		18"	24"	26"	28"
All models	Inside diameter Bolt circle diameter Length BTU rating Weight	18.5/16" 19.7/16" 22" 1400000 81	24.1/4" 25.3/4" 22.1/2" 2100000 110	26.5/16" 27.15/16" 22.1/4" 2700000 115	28.1/8" 29.5/8" 25.1/4" 3000000 140
Liquid models	Maximum fuel flow (GPH) Orifice Modulating valve bypass orifice Minimum operating pressure Maximum operating pressure Minimum line size	N/A N/A N/A N/A N/A N/A	23 3/16" Blue 2 20 3/8"	30 7/32" Blue 2 20 3/8"	34 15/64" Aluminum 2 20 3/8"
Vapor models	Maximum fuel flow (CFH) Orifice Modulating valve bypass orifice Minimum operating pressure Maximum operating pressure Minimum line size	585 5/32" Green 2 20 1/2"	877 3/16" Blue 2 20 3/4"	1128 7/32" Blue 2 20 3/4"	1253 15/64" Aluminum 2 20 3/4"
Natural gas models	Maximum fuel flow (CFH) Orifice Modulating valve bypass orifice Minimum operating pressure Maximum operating pressure Minimum line size	1473 1/4" Blue 1 7 3/4"	2210 5/16" Aluminum 1 7 1"	2842 23/64" Aluminum 1 7 1.1/4"	3157 3/8" Aluminum 1 7 1.1/4"

Low Temperature Heater Specifications

		18"	24"	26"	28"
All models	Inside diameter Bolt circle diameter Length BTU rating Weight	18.5/16" 19.7/16" 22" 400000 81	24.1/4" 25.3/4" 22.1/2" 500000 110	26.5/16" 27.15/16" 22.1/4" 500000 115	28.1/8" 29.5/8" 25.1/4" 500000 140
Vapor models	Maximum fuel flow (GPH) Orifice Modulating valve bypass orifice Minimum operating pressure Maximum operating pressure Minimum line size	167 5/64" Red 2 20 3/8"	292 3/32" Yellow 2 20 3/8"	292 3/32" Yellow 2 20 3/8"	292 3/32" Yellow 2 20 3/8"
Natural gas models	Maximum fuel flow (CFH) Orifice Modulating valve bypass orifice Minimum operating pressure Maximum operating pressure Minimum line size	421 9/64" Yellow 1 7 1/2"	736 5/32" Green 1 7 1/2"	736 5/32" Green 1 7 1/2"	736 5/32" Green 1 7 1/2"

Standard Heater Operation

1. Thermostat must be wired into heater control box for heater to operate.
2. Open all manual shutoff valves to heater unit.
3. Start fan. This will supply power to heater.
4. Turn thermostat dial to its highest setting.
5. Turn toggle switch on.
6. Heater should now be lit. If not check to see that all gas is on.
7. Watch thermometer on plenum and when it reaches desired temperature turn thermostat back slowly until heater cycles off.
8. Gas pressure should be adjusted so burner is on 75% of the time.
9. Watch plenum temperature as burner goes through a few cycles, to be sure that it is operating properly.

Hi-Lo Heater Operation

1. Hi-limit and cycling thermostat must be wired into heater control box for heater to operate.
2. Open all manual shutoff valves to heater unit.
3. Start fan. This will supply power to heater.
4. Turn thermostat dial to its highest setting.
5. Turn toggle switch on. Both red lights should light up indicating power to the control circuit.
6. Heater should now be lit. If not check to see that all gas is on.
7. Open low-fire ball valve all the way.
8. Turn thermostat dial back slowly until heater cycles to low flame.
9. Adjust ball valve so that low-flame pressure is at desired setting.
10. Turn thermostat dial to desired setting and wait for bin plenum to come up to temperature. Heater should cycle to low flame after a few minutes. If heater does not cycle to low flame increase hi-flame gas pressure.
11. Low-flame should be adjusted so that temperature drops slowly until burner goes back to high flame.
12. Watch as burner goes through a few cycles, to be sure that it is operating properly, back to high flame.

Modulating Valve Operation

1. The modulating valve regulates gas flow through the heater based on sensing unit in the plenum, and maintains a constant drying air temperature.
2. The sensing bulb of the modulating valve should be mounted through the bin wall with the side reading "top" up. The bulb reacts to temperature. It changes the amount of gas (increase or decrease), burning warmer or cooler depending on the position of the valve SET POINT. If the bulb is cooler than it was at the SET POINT, the bulb senses the cooler temperature and opens the valve further so more heat is applied to the drying air. If the bulb is warmer than it was at the SET POINT, the valve closes further and reduces the temperature until the air is at the valve SET POINT.
3. It is important that the pressure regulator be set high enough to allow the modulating valve to deliver enough gas to maintain the plenum temperature necessary. The regulator is normally factory set at 15 psi (propane units). To set the regulator, run the heater and turn the modulating valve T-handle in. This gets full line pressure to the burner. Then adjust regulator to read 15 psi (depending on the plenum temperature needed).
4. Turn the fan and heater on. To set the modulating valve, turn the T-handle out (counterclockwise) until loose and wait a few minutes for the plenum temperature to equalize. When the temperature under the bin has equalized, gradually turn T-handle in (clockwise) about 1/2 turn at a time.

Wait until temperature under bin has equalized as before. If temperature under bin is less than the desired temperature, continue turning T-handle in, increasing gas flow and waiting for plenum temperature to equalize until the desired temperature is the stable temperature of the plenum. If temperature under bin is the same 10 minutes after you last made any adjustments to the T-handle you can be certain that the temperature under the bin is the SET POINT of the valve. **1 turn of the T-handle equals approximately 7 degrees F of temperature.**
5. The valve will now keep the plenum temperature at the set point regardless of ambient conditions as long as humidistat or thermostat do not shut down the heater. A bypass orifice is used to maintain a small flame when outside temperature is near or above the set point of the valve. The bypass insures steady application of heat at minimum gas flow operation. Bypass orifice will only operate correctly if pressure regulator is set correctly.
6. To observe how the modulating valve increases the efficiency of bin drying, check the gas pressure of the unit in the morning and compare to the pressure read mid-afternoon. If the ambient (outside) temperature is significantly greater later in the day (as normal), the gas pressure will be less. Since less heat is required to maintain the same temperature in the plenum, the modulating valve will have reduced the amount of gas used by the heater.

BTU's Per Gauge Pressure (PSI) Propane Models (Approximate)

High Temperature

Diameter	Operating Pressure (PSI)									
	2	4	6	8	10	12	14	16	18	20
18"	416380	588680	720290	832760	930880	1019420	1107800	1174960	1244360	1340080
24"	598250	844730	1036170	1198890	1340080	1464520	1581770	1689460	1787570	1892860
26"	816010	1148640	1409480	1632030	1825860	1995762	2153700	2302070	2436070	2577260
28"	935660	1318540	1617670	1868930	2091480	2309250	2467180	2649050	2792630	2955360

Low Temperature

Diameter	Operating Pressure (PSI)									
	2	4	6	8	10	12	14	16	18	20
18"	102900	145970	181870	208190	234510	253660	275200	294340	311090	335020
24-28"	148370	210580	258440	299130	335020	366130	394850	421170	447490	473810

**Gauge Pressure (PSI) Required to Maintain Temperature (Approximate)
(High Temp Units Only)**

Fan Model	Static Pressure	Heat Rise Degrees F							
		60	80	100	120	140	160	180	
3HP-18"	1"	2	3	4	5	6	8	9	
	2"	1	1	2	3	4	5	6	
	3"	low-temp	low-temp	1	2	2	3	3	
7HP-24"	1"	2	4	6	8	10	14	17	
	2"	1	3	4	5	7	9	11	
	3"	low-temp	low-temp	1	2	3	3	4	
	4"	low-temp	low-temp	low-temp	low-temp	1	2	3	
10HP-24"	1"	4	6	9	13	18	22	26	
	2"	3	5	8	10	14	18	22	
	3"	2	3	4	6	8	9	11	
	4"	1	2	3	4	5	6	8	
15HP-26"	1"	2	4	6	8	11	14	18	
	2"	2	4	5	7	9	13	16	
	3"	1	3	4	5	7	10	13	
	4"	1	3	4	5	7	9	11	
	5"	low-temp	1	2	3	3	4	5	
15HP-28"	1"	3	4	7	9	12	16	20	
	2"	2	4	6	8	11	14	18	
	3"	2	3	4	5	8	10	13	
	4"	1	2	3	4	6	8	10	
	5"	low-temp	1	2	3	3	4	5	

**BTU's Per Gauge Pressure (PSI) Natural Gas Models (Approximate)
High Temperature**

Diameter	Operating Pressure (PSI)						
	1	2	3	4	5	6	7
18"	454180	644780	787970	909260	1016880	1115380	1204750
24"	710450	1006850	1231200	1419980	1587790	1741920	1881456
26"	938450	1331520	1627920	1876896	2099420	2302800	2487940
28"	1022350	1450080	1772020	2043790	2285470	2507090	2708640

Low Temperature

Diameter	Operating Pressure (PSI)						
	1	2	3	4	5	6	7
18"	144100	205200	250800	289100	322850	353860	383040
24-28"	177840	251710	308260	355680	397632	435936	470590

**Gauge Pressure (PSI) Required to Maintain Temperature (Approximate)
(High Temp Units Only)**

Fan Model	Static Pressure	Heat Rise Degrees F						
		60	80	100	120	140	160	180
3HP-18"	1"	1	1	2	2	3	3	4
	2"	1	1	1	1	2	2	3
	3"	low-temp	low-temp	1	1	1	1	31
7HP-24"	1"	1	2	2	3	4	5	6
	2"	1	1	1	2	2	3	4
	3"	low-temp	low-temp	1	1	1	1	2
	4"	low-temp	low-temp	low-temp	1	1	1	1
10HP-24"	1"	2	2	4	5	6	7	8
	2"	1	2	3	3	4	6	7
	3"	1	1	1	2	2	3	4
	4"	low-temp	1	1	1	1	2	2
15HP-26"	1"	1	2	2	3	4	5	7
	2"	1	1	2	3	3	4	5
	3"	1	1	2	2	3	3	4
	4"	1	1	1	1	2	2	3
	5"	low-temp	low-temp	1	1	1	1	2
15HP-28"	1"	1	2	3	4	5	7	8
	2"	1	2	2	3	4	5	6
	3"	1	1	2	2	3	4	5
	4"	1	1	1	1	2	2	3
	5"	low-temp	low-temp	1	1	1	2	2

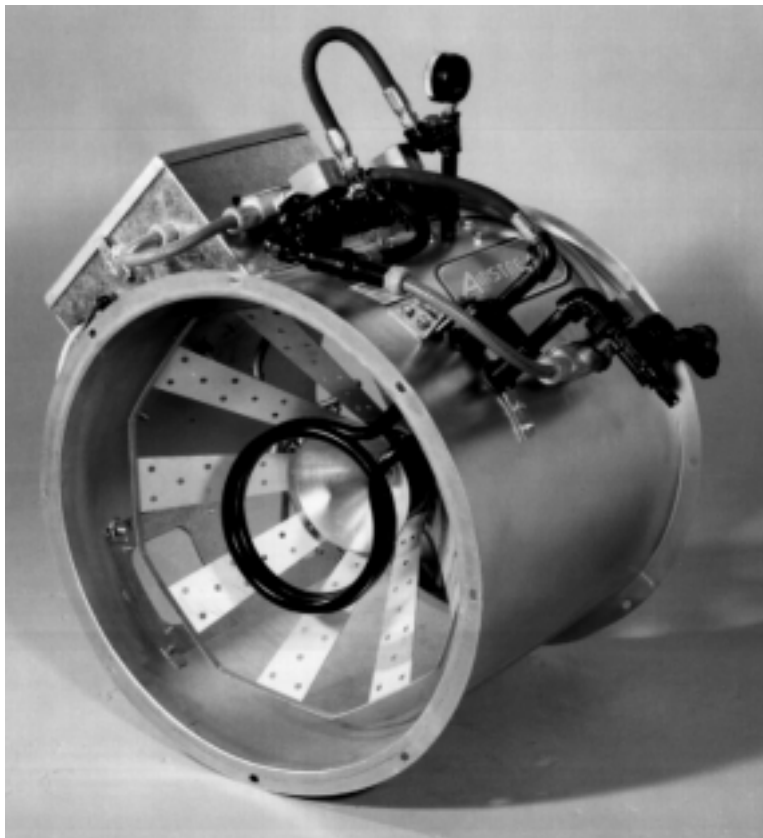
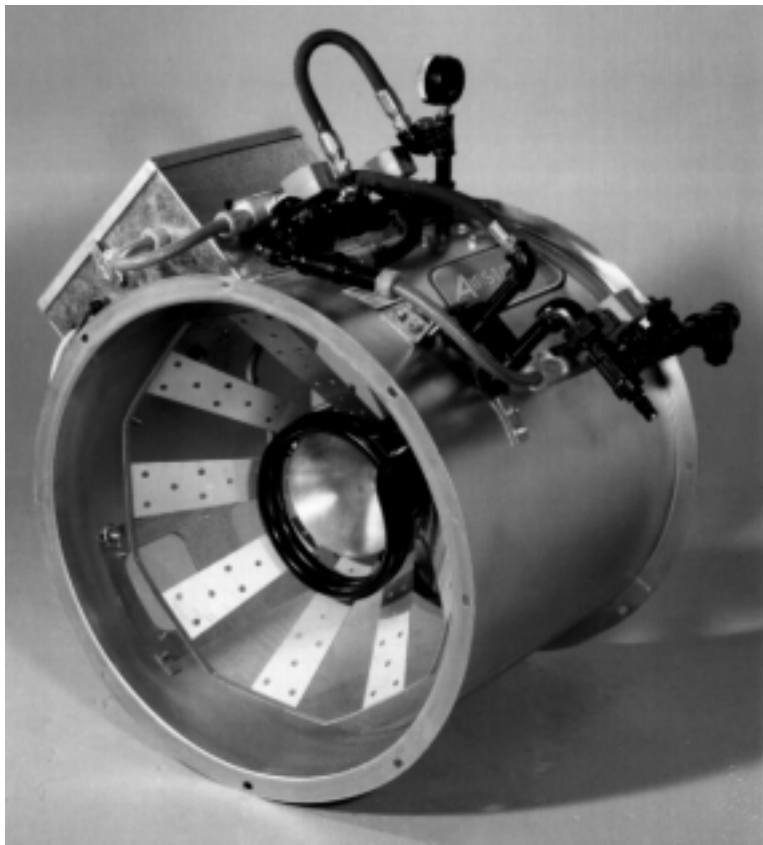

Adjusting the vaporizer coil on a liquid propane model. The top photo shows the setting in, and the bottom photo shows the coil out.

Adjusting the Vaporizer

1. Vaporizer should be adjusted so the vapor pipetrain runs warm to the touch (100°-120°F).
2. Loosen 5/16" bolt on adjustment bracket.
3. Swivel vaporizer away from flame if running too hot, closer to flame if too cold.
4. Move vaporizer only 1" at a time and allow a few minutes for temperature to equalize.
5. Tighten 5/16" bolt and watch heater run for several minutes to verify adjustment.

DELUXE HEATER WIRING DIAGRAM

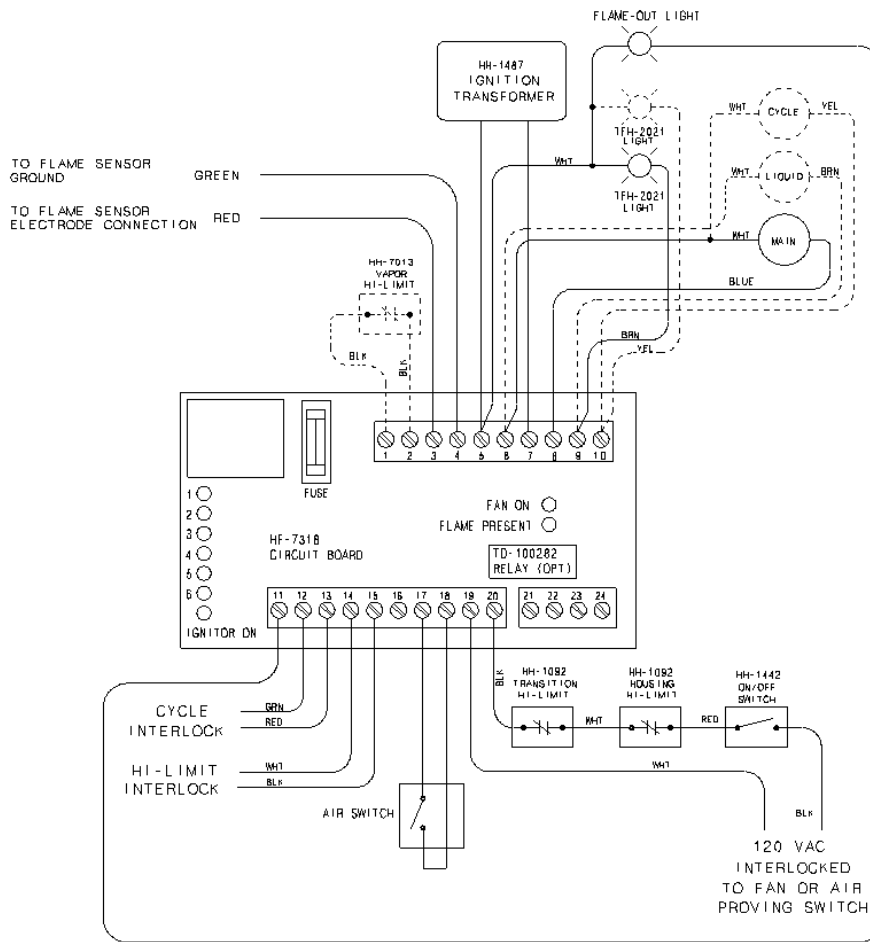

● INDICATES LIGHT ON ○ INDICATES LIGHT OFF

INDICATION	POSSIBLE CAUSE	POSSIBLE SOLUTION
○ ○ ○ ○ ○ ○	Bad On/Off Switch	Replace Switch
○ ○ ○ ○ ○ ○	Heater Housing Hi-Limit	Reset Or Replace Hi-Limit
1 2 3 4 5 6	Transition Hi-Limit	Reset Or Replace Hi-Limit
	No Power To Heater	Check Heater
● ○ ○ ○ ○ ○	Blown Fuse	Replace Fuse
● ● ○ ○ ○ ○	Flame Sensor (if flame present light on)	Clean Or Replace Flame Sensor
1 2 3 4 5 6	Control Board	Replace Control Board
	Air Switch (if fan on light not on)	Check Air Switch
● ● ● ○ ○ ○	Vaporizer Hi-Limit	Adjust Vaporizer Coil Replace Vapor Hi-Limit
● ● ● ● ○ ○	Humidistat/Thermostat	Temperature Reached Replace Thermostat Or Humidistat
● ● ● ● ● ○	Spark Plug	Clean Or Replace Spark Plug
1 2 3 4 5 6	No Fuel To Burner	Check Fuel Supply
	Bad Solenoid	Replace Solenoid

● ● ● ● ● ○ WAIT FOR 20 SECOND PURGE DELAY TO TROUBLESHOOT!
 1 2 3 4 5 6 INDICATING LIGHTS SHOWN ON LEFT SHOULD BE LIT WHEN UNIT IS OPERATING PROPERLY

DC-1161

18" Gas Heater

1	HF-6785	18" Heater Housing
2	HH-3933	18" Burner Casting
3	HH-1180	18" Flame Spreader
3	HH-4410	18" Lo-Temp Flame Spreader
4	HF-7078	18" Flame Diverter
4	HF-7073	18" Lo-Temp Flame Diverter
5	HF-6062-18	18" Access Panel (Deluxe, Sr 2000)
6	HF-7380	Plastic View Window
7	HF-7379	Access Panel Cover Plate
8	TFH-2046	Access Panel Latch
9	HF-983	18/24" Burner Collector
10	HF-978	18/24/26" Burner Collector Plate
11	HH-4416	Drum Grill Guard (LTD)
12	HH-4421	Stand-Off Bracket (LTD)
13	F-953	18" Grill Guard (LTD)
14	HH-1650	Spark Plug
NS	HF-1810	Spark Plug Nut
NS	HF-7260	18-28" Heater Spark Plug Wire
NS	HF-7262	18-28" Heater Flame Probe Wire
15	*THH-4179	Flame Sensor (Deluxe, Sr 2000)
16	CD-0187	Flame Sensor Bracket (Deluxe, Sr 2000)

18" Gas Heater

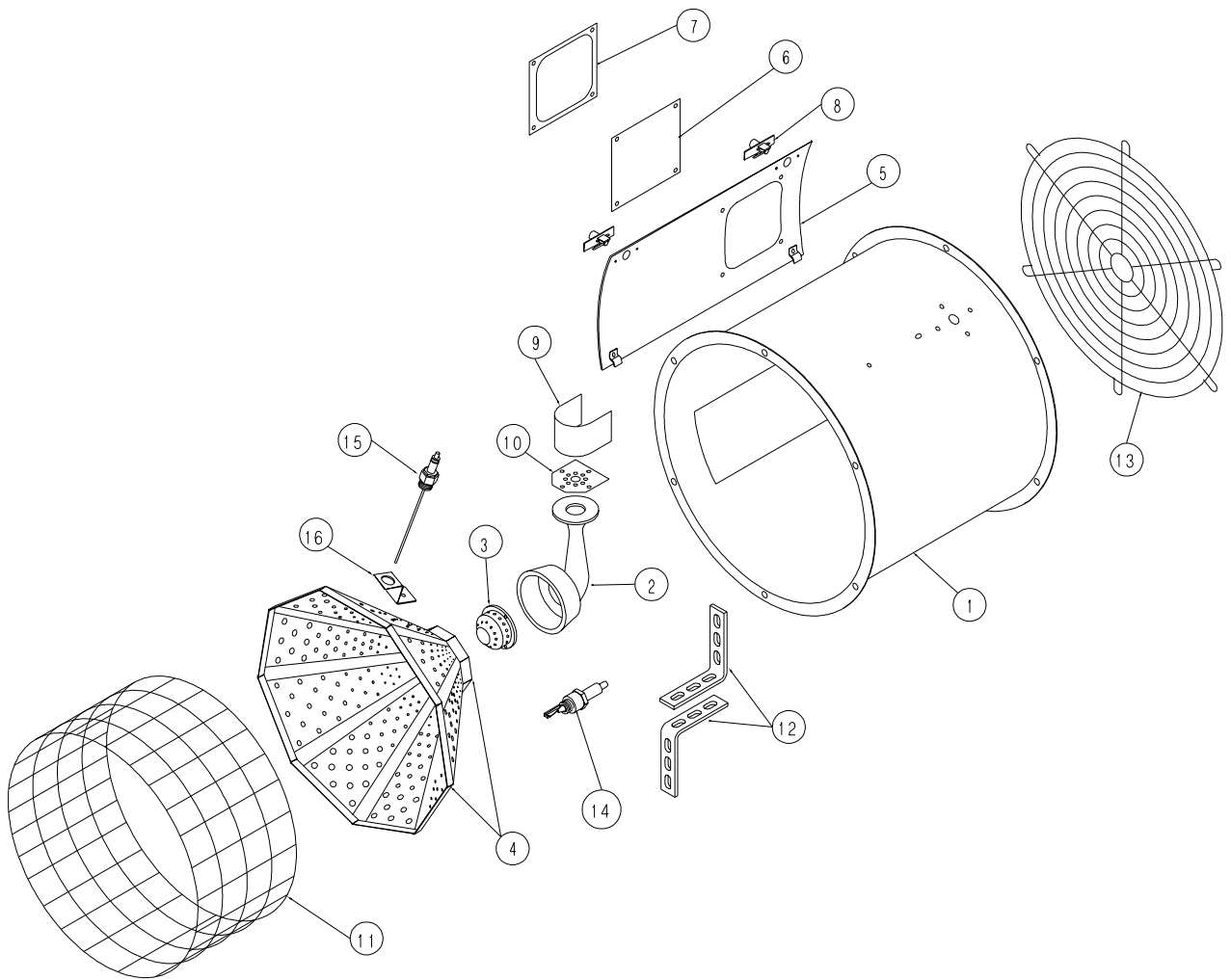

24" & 26" Gas Heater

1	HF-6175	24" Heater Housing
1	HF-6176	26" Heater Housing
2	HH-3934	24/26" Burner Casting
3	HH-1179	24/26" Flame Spreader
3	HF-6757	24/26/28" Lo-Temp Flame Spreader
4	HF-7103	24/26" Flame Diverter
4	HF-7107	24/26/28" Lo-Temp Flame Diverter
4	HF-7104	24/26" Diverter Collar
5	HF-6062-24	24" Access Panel (Deluxe, Sr 2000)
5	HF-6062-26	26" Access Panel (Deluxe, Sr 2000)
6	HF-7380	Plastic View Window
7	HF-7379	Access Panel Cover Plate
8	TFH-2046	Access Panel Latch
9	HF-983	18/24" Burner Collector
9	HF-986	26" Burner Collector
10	HF-978	18/24/26" Burner Collector Plate
11	HH-7016	Rubber Grommet
12	HF-7056	Pivot Bracket
13	HF-7057	Adjustment Bracket
14	HF-7060	Vaporizer Support Weldment
15	THF-3237	Vaporizer Cover
16	HH-1650	Spark Plug
NS	HF-1810	Spark Plug Nut
NS	HF-7260	18-28" Heater Spark Plug Wire
NS	HF-7262	18-28" Heater Flame Probe Wire
17	*THH-4179	Flame Sensor (Deluxe, Sr 2000)
18	CD-0187	Flame Sensor Bracket (Deluxe, Sr 2000)
19	HH-7054	24-28" Burner Cone

24" & 26" Gas Heater

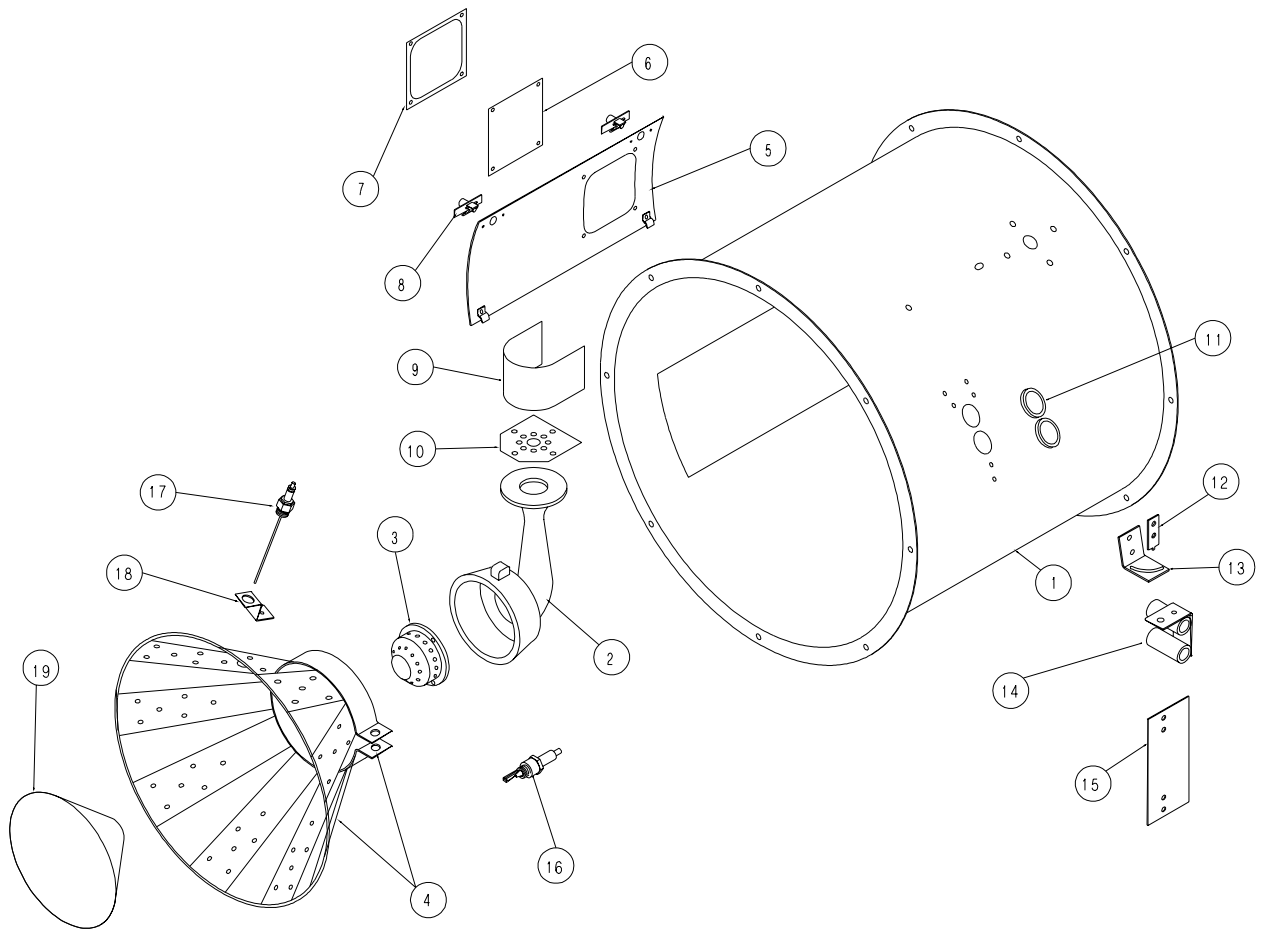

28" Gas Heater

1	HF-6060	28" Heater Housing
2	HH-3934	24/26" Burner Casting
2	THF-3141	28" Burner Casting
3	THF-3144	28" Flame Spreader
3	HF-6757	24/26/28" Lo-Temp Flame Spreader
4	HF-7105	28" Flame Diverter
4	HF-7107	24/26/28" Lo-Temp Flame Diverter
4	HF-7106	28" Diverter Collar
4	HF-7104	24/26" Diverter Collar
5	HF-6062-28	28" Access Panel (Deluxe, Sr 2000)
6	HF-7380	Plastic View Window
7	HF-7379	Access Panel Cover Plate
8	TFH-2046	Access Panel Latch
9	THF-3101	28" Burner Collector
9	HF-986	26" Burner Collector
10	HF-7092	28" Burner Collector Plate
10	HF-978	18/24/26" Burner Collector Plate
11	HH-7016	Rubber Grommet
12	HF-7056	Pivot Bracket
13	HF-7057	Adjustment Bracket
14	HF-7060	Vaporizer Support Weldment
15	THF-3237	Vaporizer Cover
16	HH-1650	Spark Plug
NS	HF-1810	Spark Plug Nut
NS	HF-7260	18-28" Heater Spark Plug Wire
NS	HF-7262	18-28" Heater Flame Probe Wire
17	*THH-4179	Flame Sensor (Deluxe, Sr 2000)
18	CD-0187	Flame Sensor Bracket (Deluxe, Sr 2000)
19	HH-7054	24-28" Burner Cone

28" Gas Heater

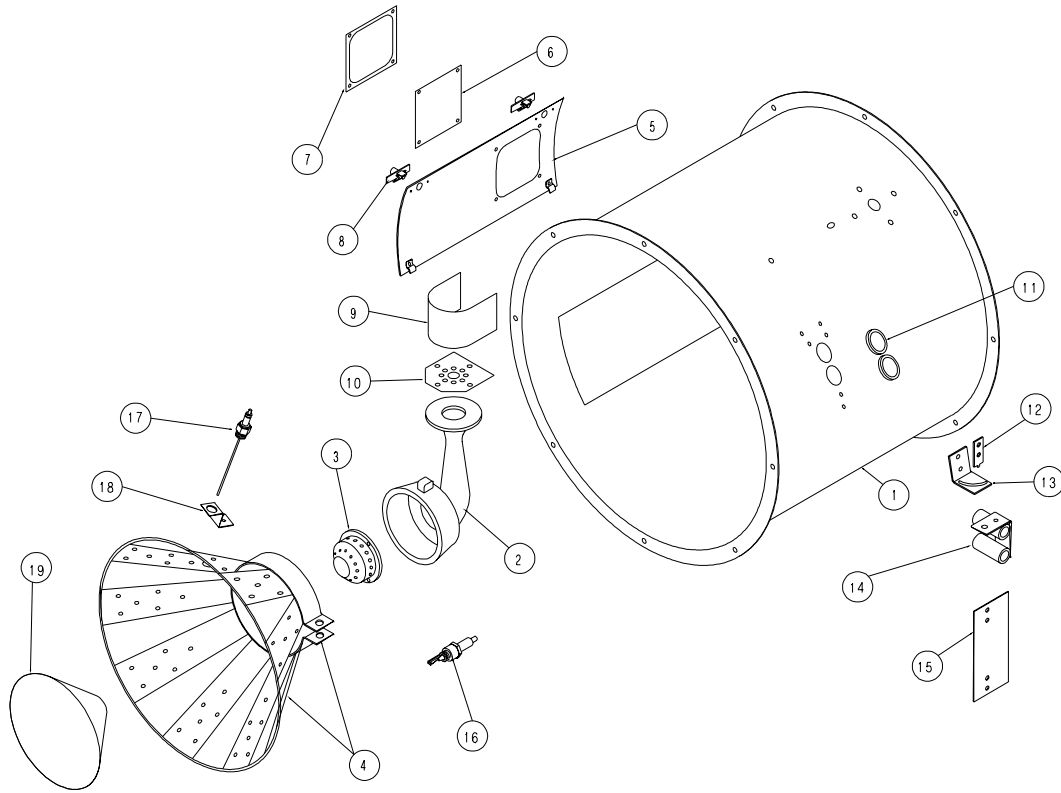

Control Box Parts

Key	Part Number	Description
1	F-942	Control Box Lid
2	HH-1487	Igniton Transformer
3	HF-7318	Circuit Board Assembly
4	HH-1092	High Limit Switch 180 Degree
5	FH-4429-1	Spring Latch
6	HH-7015	Snap trak
7	HF-7046	18" Control Box Housing
7	HF-7047	24" Control Box Housing
7	HF-7098	26" Control Box Housing
7	HF-7051	28" Control Box Housing
8	DC-1166	Decal Deluxe Heater Front Panel
9	TFH-2021	Red Light (110V)
10	HH-1442	Toggle Switch
11	HF-7455	High Limit Switch Box Bottom
12	HF-7439	High Limit Switch 250 Degree
13	HF-7454	High Limit Switch Box Top
14	HF-7414	Recessed Plastic Plug
15	TD-100282	Optional Relay
15	FH-1310	Cord Connector

Control Box Parts

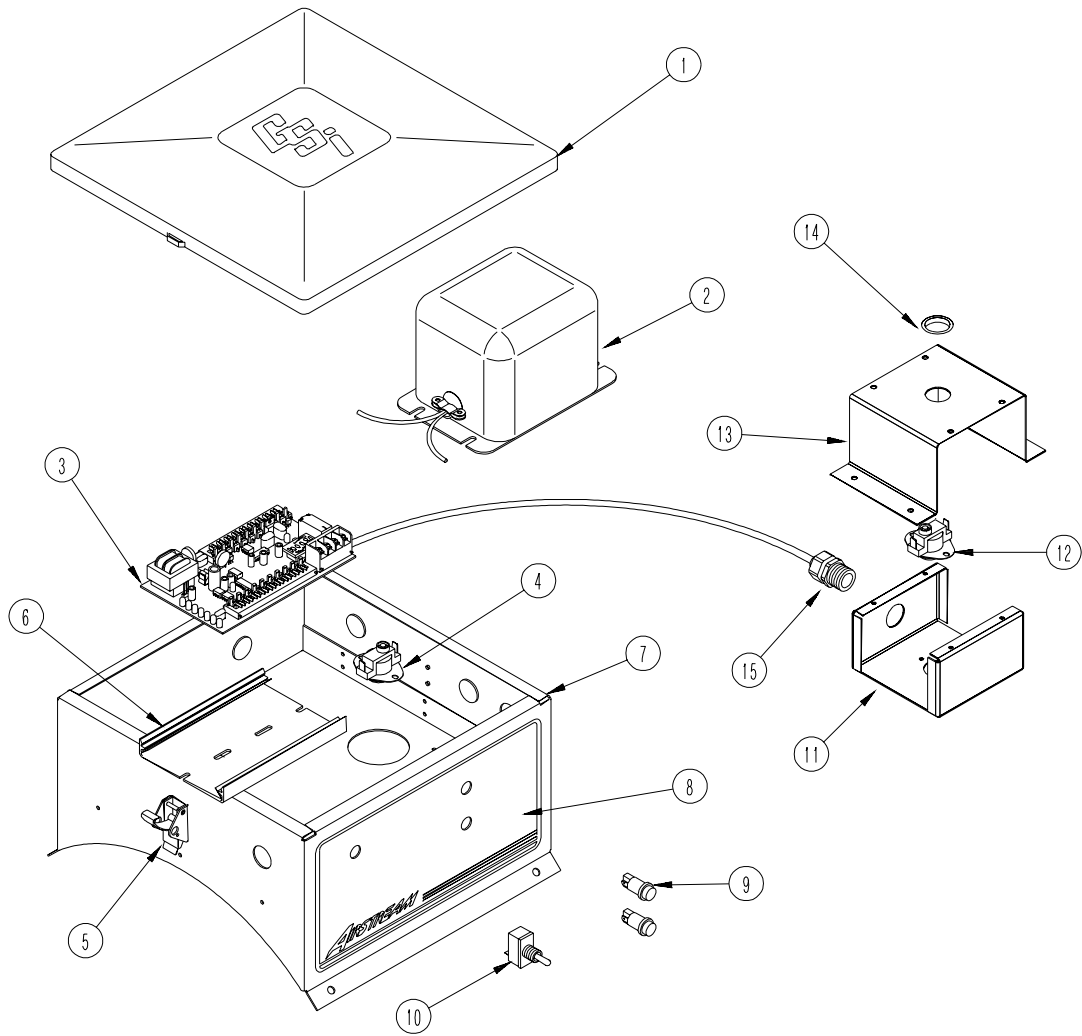

Axial Propane Vapor Pipetrain

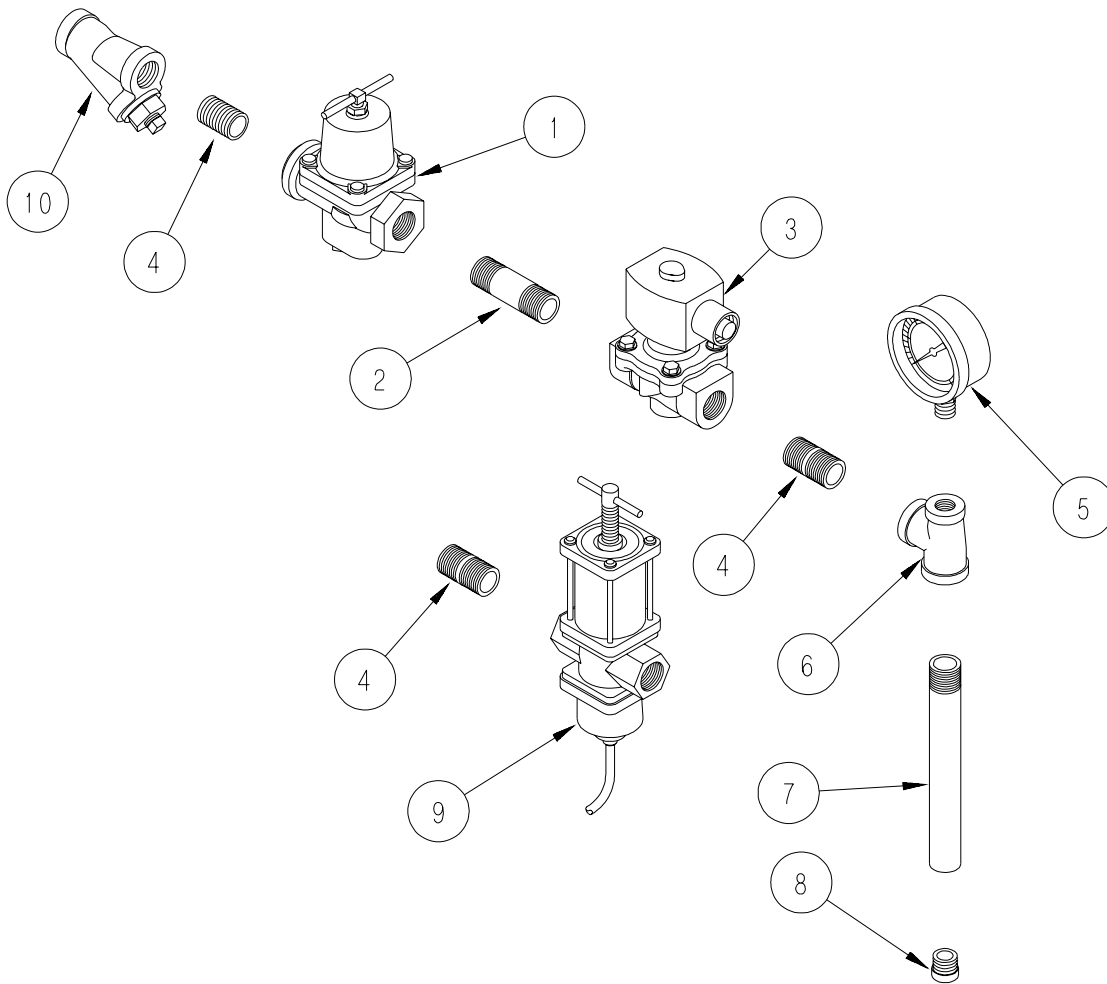

1	TFC-0023	1/2" 0-30 PSI Regulator (Deluxe, Sr 2000)
2	HH-3670	1/2" x 2 1/2" Nipple
3	TFC-0032	1/2" Solenoid (Deluxe, Sr 2000)
4	HH-2029	1/2" x 1 1/2" Nipple
5	HH-2984	30 PSI gauge
6	S-3853	1/2" x 1/4" x 1/2" Tee
7	HH-1083	18/24/28" Orifice Pipe
7	HH-1107	26" Orifice Pipe
8	HF-7036	5/32" Orifice Plug (18" Standard)
8	CD-0149	5/64" Orifice Plug (18" Lo-Temp)
8	HF-7086	3/16" Orifice Plug (24" Standard)
8	HF-7084	3/32" Orifice Plug (24/26/28" Lo-Temp)
8	HF-7087	7/32" Orifice Plug (26" Standard)
8	HF-7088	15/64" Orifice Plug (28" Standard)
9	HH-2653	Modulating Valve (Optional)
10	HH-1251	1/2" Strainer

Axial Natural Gas Pipetrain

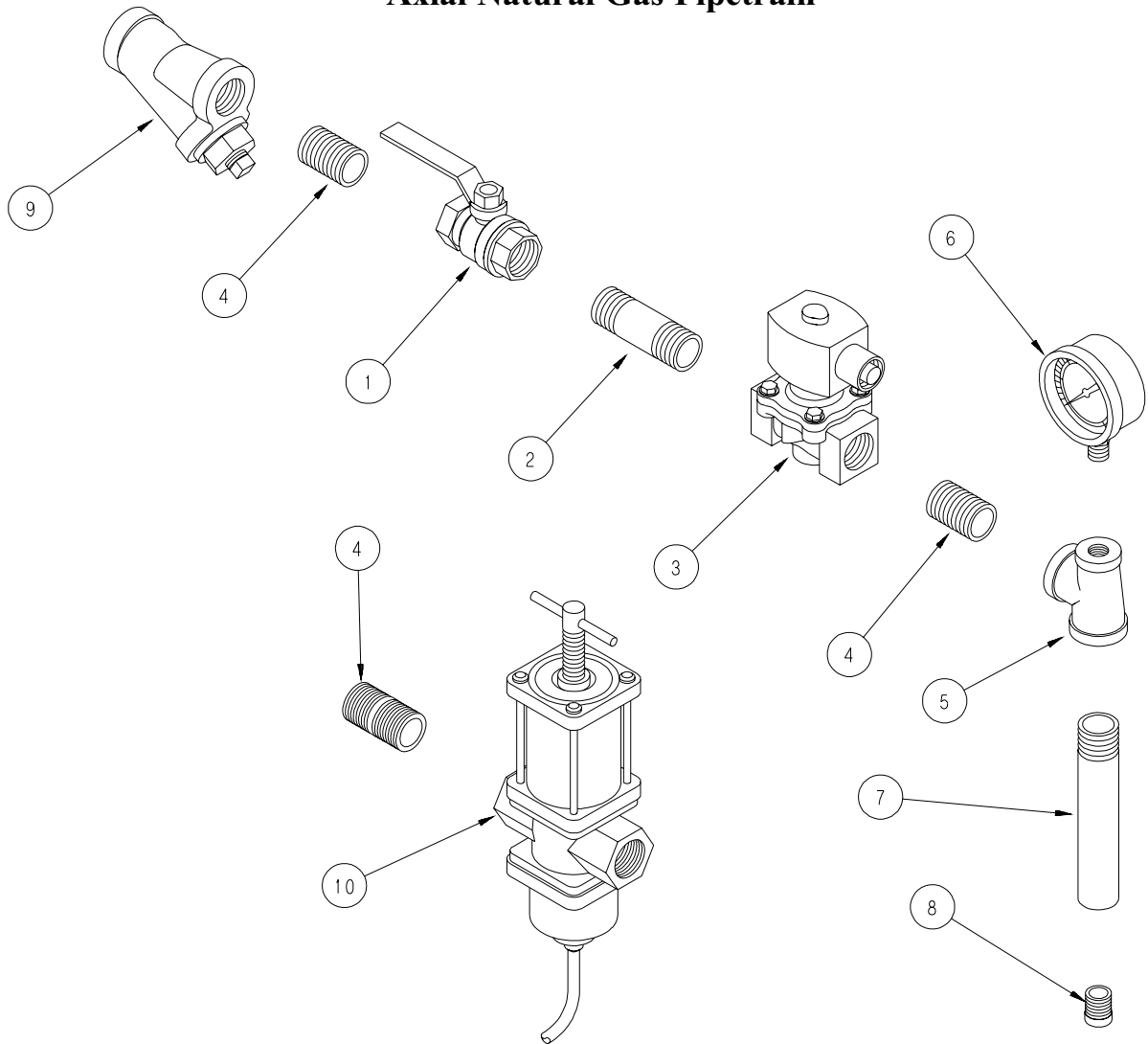

1	TFC-0051	3/4" Ball Valve
2	THH-4136	3/4" x 3" Nipple
3	TFC-0081	3/4" Solenoid (Deluxe, Sr 2000)
4	THH-4121	3/4" Close Nipple
5	THH-4158	3/4" x 1/4" x 3/4" Tee
6	D08-0022	15 PSI Gauge
7	HH-7026	3/4" 18/24/28" Orifice Pipe
7	HH-7027	3/4" 26" Orifice Pipe
8	HF-7123	1/4" Orifice Plug (18" Standard)
8	HF-7124	5/16" Orifice Plug (24" Standard)
8	HF-7125	23/64" Orifice (26" Standard)
8	HF-7126	3/8" Orifice (28" Standard)
9	D67-0008	3/4" Strainer
10	HH-7064	3/4" Modulating Valve (Optional)

Axial Propane Vapor Hi-Lo Pipetrain

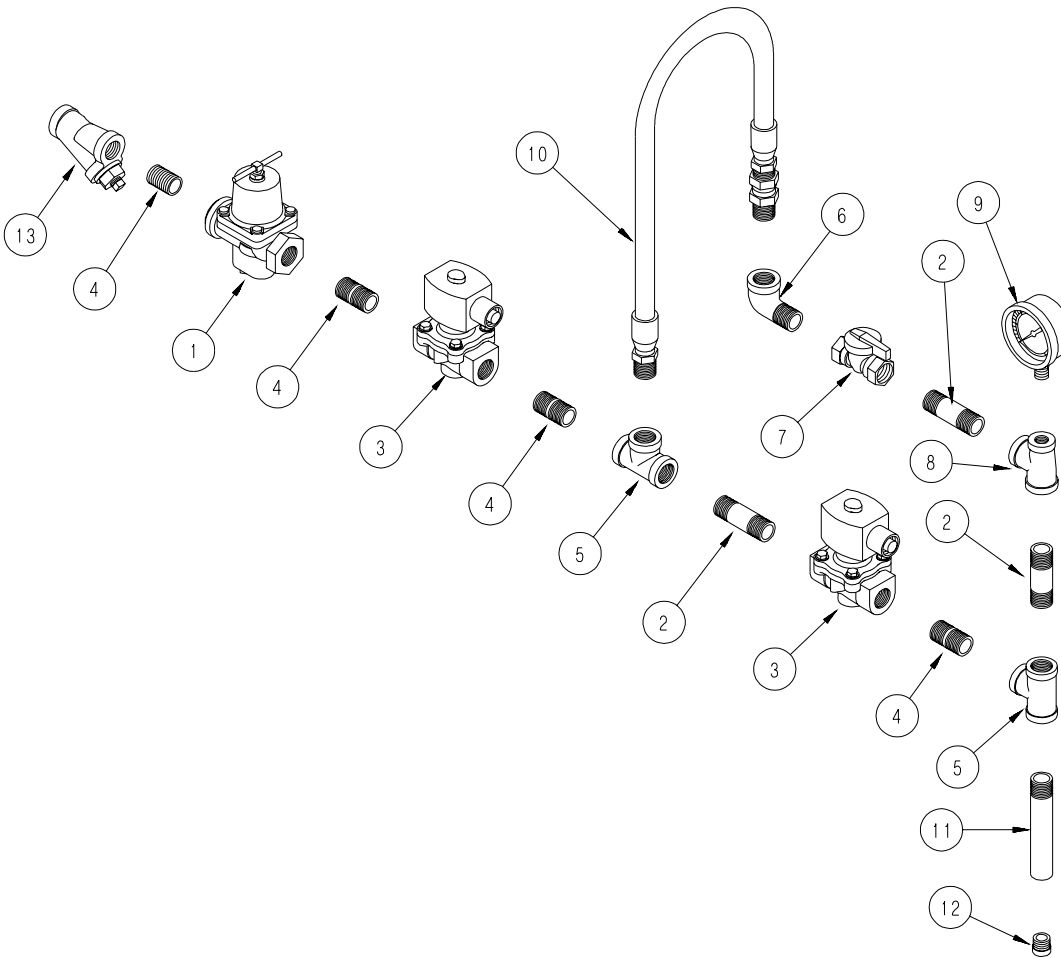

1	TFC-0023	1/2" 0-30 PSI Regulator (Deluxe, Sr 2000)
2	HH-3670	1/2" x 2 1/2" Nipple
3	TFC-0032	1/2" Solenoid (Deluxe, Sr 2000)
4	HH-2029	1/2" x 1 1/2" Nipple
5	HH-1453	1/2" x 1/2" x 1/2" Tee
6	THH-4067	1/2" Street Elbow
7	TFC-0030	1/2" Ball Valve
8	S-3853	1/2" x 1/4" x 1/2" Tee
9	HH-2984	30 PSI gauge
10	HH-7019	1/2" Gas Hose
11	HH-1107	26" Orifice Pipe
11	HH-1083	18/24/28" Orifice Pipe
12	HF-7036	5/32" Orifice Plug (18" Standard)
12	HF-7086	3/16" Orifice Plug (24" Standard)
12	HF-7087	7/32" Orifice Plug (26" Standard)
12	HF-7088	15/64" Orifice Plug (28" Standard)
13	HH-1251	1/2" Strainer

Axial Natural Gas Hi-Lo Pipetrain

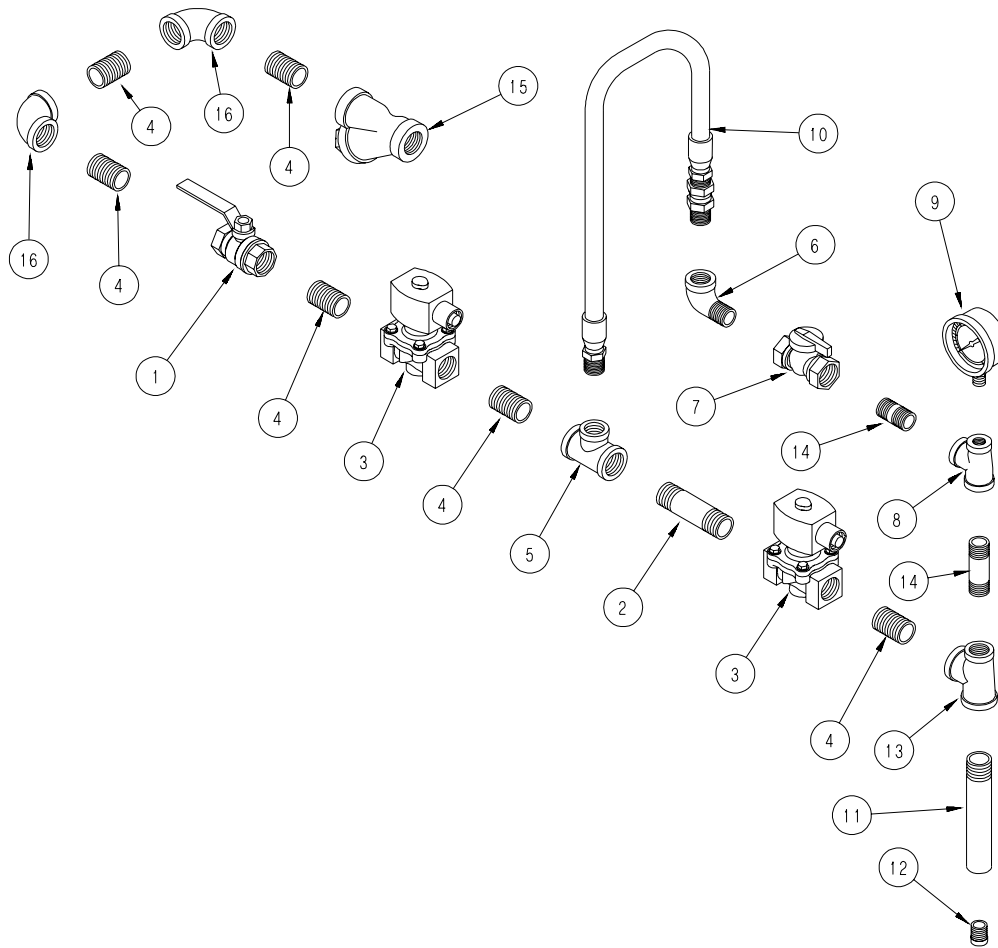

1	TFC-0051	3/4" Ball Valve
2	THH-4136	3/4" x 3" Nipple
3	TFC-0081	3/4" Solenoid (Deluxe, Sr 2000)
4	THH-4121	3/4" Close Nipple
5	THH-4174	3/4" x 3/4" x 1/2" Tee
6	THH-4067	1/2" Street Elbow
7	TFC-0030	1/2" Ball Valve
8	S-3853	1/2" x 1/4" x 1/2" Tee
9	D08-0022	15 PSI Gauge
10	HH-7019	1/2" Gas Hose
11	HH-7026	3/4" 18/24/28" Orifice Pipe
11	HH-7027	3/4" 26" Orifice Pipe
12	HF-7123	1/4" Orifice Plug (18" Standard)
12	HF-7124	5/16" Orifice Plug (24" Standard)
12	HF-7125	23/64" Orifice (26" Standard)
12	HF-7126	3/8" Orifice (28" Standard)
13	D18-0002	3/4" x 1/2" x 3/4" Tee
14	HH-3670	1/2" x 2 1/2" Nipple
15	D67-0008	3/4" Strainer

Axial LP Pipetrain

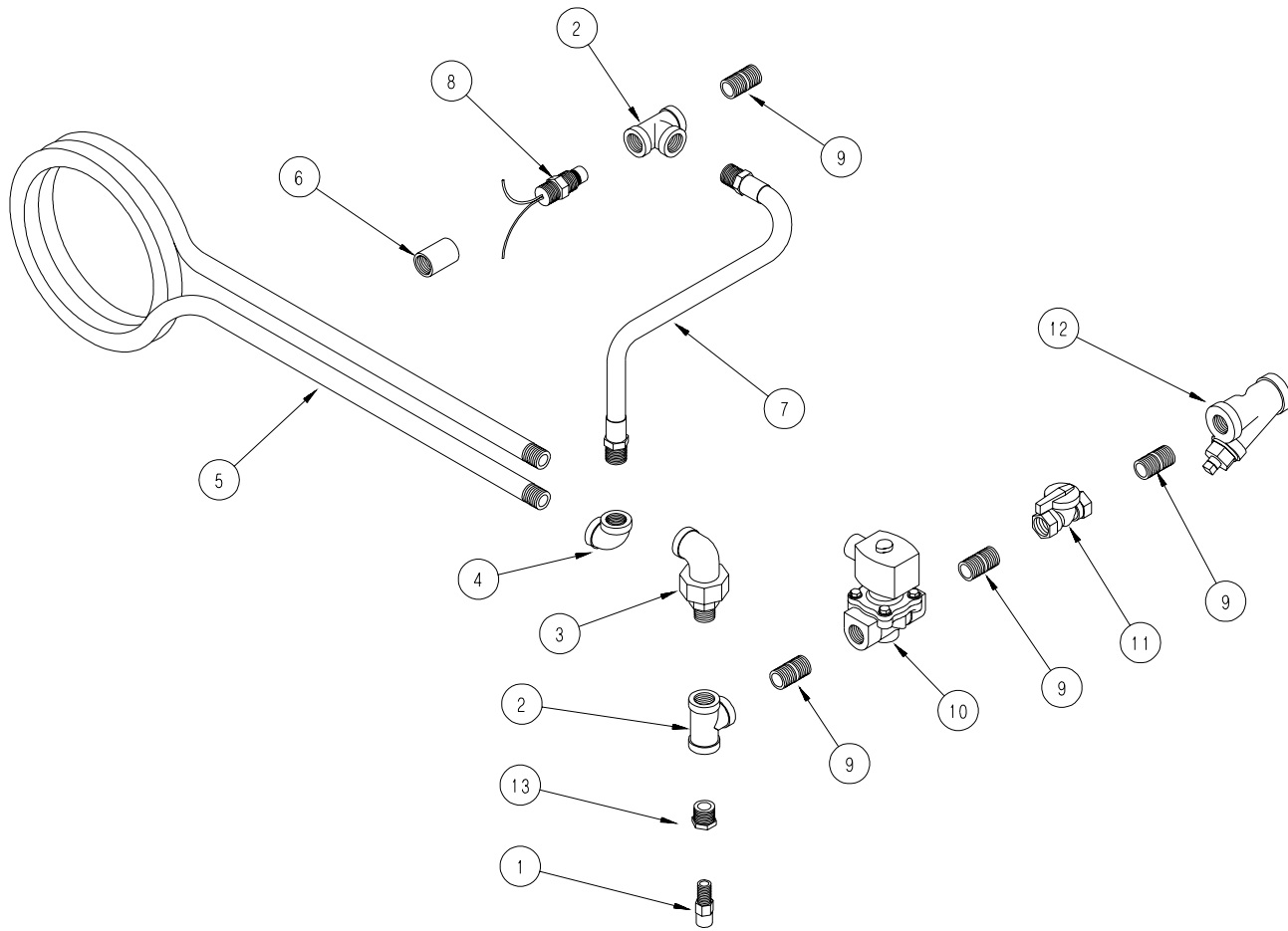

1	HH-4845	1/4" Relief Valve
2	THH-4058	1/2" x 1/2" x 1/2" Tee Sh. 80
3	THH-4089	1/2" Male Union Elbow Sh. 80
4	THH-4071	1/2" Elbow Sh. 80
5	CD-0198	Vaporizer Coil
6	D67-0005	1/2" Coupling
7	D07-0009	5/16" x 24" LP Gas Hose
8	HH-7013	200 Degree Vapor High Limit
9	D07-0019	1/2" x 1 1/2" Nipple Sh. 80
10	TFC-0092	1/2" Solenoid Valve 300 PSI
11	TFC-0030	1/2" Ball Valve
12	HH-1251	1/2" Strainer
13	THH-4023	1/2" x 1/4" Reducer Bushing

THE GSI GROUP INC. (GSI) WARRANTS ALL PRODUCTS MANUFACTURED BY GSI TO BE FREE OF DEFECTS IN MATERIAL AND WORKMANSHIP UNDER NORMAL USAGE AND CONDITIONS FOR A PERIOD OF 36 MONTHS AFTER RETAIL SALE TO THE ORIGINAL END USER OF SUCH PRODUCTS. GSI'S ONLY OBLIGATION IS, AND PURCHASER'S SOLE REMEDY SHALL BE FOR GSI, TO REPAIR OR REPLACE, AT GSI'S OPTION AND EXPENSE, PRODUCTS THAT, IN GSI'S SOLE JUDGMENT, CONTAIN A MATERIAL DEFECT DUE TO MATERIALS OR WORKMANSHIP. ALL DELIVERY AND SHIPMENT CHARGES TO AND FROM GSI'S FACTORY WILL BE PURCHASER'S RESPONSIBILITY. EXPENSES INCURRED BY OR ON BEHALF OF THE PURCHASER WITHOUT PRIOR WRITTEN AUTHORIZATION FROM AN AUTHORIZED EMPLOYEE OF GSI SHALL BE THE SOLE RESPONSIBILITY OF THE PURCHASER.

EXCEPT FOR THE ABOVE STATED EXPRESS LIMITED WARRANTIES, GSI MAKES NO WARRANTY OF ANY KIND, EXPRESSED OR IMPLIED, INCLUDING, WITHOUT LIMITATION, WARRANTIES OF MERCHANTABILITY OR FITNESS FOR A PARTICULAR PURPOSE OR USE IN CONNECTION WITH (i) PRODUCT MANUFACTURED OR SOLD BY GSI OR (ii) ANY ADVICE, INSTRUCTION, RECOMMENDATION OR SUGGESTION PROVIDED BY AN AGENT, REPRESENTATIVE OR EMPLOYEE OF GSI REGARDING OR RELATED TO THE CONFIGURATION, INSTALLATION, LAYOUT, SUITABILITY FOR A PARTICULAR PURPOSE, OR DESIGN OF SUCH PRODUCT OR PRODUCTS.

IN NO EVENT SHALL GSI BE LIABLE FOR ANY DIRECT, INDIRECT, INCIDENTAL OR CONSEQUENTIAL DAMAGES, INCLUDING, WITHOUT LIMITATION, LOSS OF ANTICIPATED PROFITS OR BENEFITS. PURCHASER'S SOLE AND EXCLUSIVE REMEDY SHALL BE LIMITED TO THAT STATED ABOVE, WHICH SHALL NOT EXCEED THE AMOUNT PAID FOR THE PRODUCT PURCHASED. THIS WARRANTY IS NOT TRANSFERABLE AND APPLIES ONLY TO THE ORIGINAL PURCHASER. GSI SHALL HAVE NO OBLIGATION OR RESPONSIBILITY FOR ANY REPRESENTATIVE OR WARRANTIES MADE BY OR ON BEHALF OF ANY DEALER, AGENT OR DISTRIBUTOR OF GSI.

GSI ASSUMES NO RESPONSIBILITY FOR FIELD MODIFICATIONS OR ERECTION DEFECTS WHICH CREATE STRUCTURAL OR STORAGE QUALITY PROBLEMS. MODIFICATIONS TO THE PRODUCT NOT SPECIFICALLY COVERED BY THE CONTENTS OF THIS MANUAL WILL NULLIFY ANY PRODUCT WARRANTY THAT MIGHT HAVE BEEN OTHERWISE AVAILABLE.

THE FOREGOING WARRANTY SHALL NOT COVER PRODUCTS OR PARTS WHICH HAVE BEEN DAMAGED BY NEGLIGENT USE, MISUSE, ALTERATION OR ACCIDENT. THIS WARRANTY COVERS ONLY PRODUCTS MANUFACTURED BY GSI. THIS WARRANTY IS EXCLUSIVE AND IN LIEU OF ALL OTHER WARRANTIES EXPRESS OR IMPLIED. GSI RESERVES THE RIGHT TO MAKE DESIGN OR SPECIFICATION CHANGES AT ANY TIME.

PRIOR TO INSTALLATION, PURCHASER HAS THE RESPONSIBILITY TO RESEARCH AND COMPLY WITH ALL FEDERAL, STATE AND LOCAL CODES WHICH MAY APPLY TO THE LOCATION AND INSTALLATION.



a division of

THE GSI GROUP



1004 E. Illinois St.
Assumption, IL 62510
phone 217-226-4421
fax 217-226-4498
<http://www.grainsystems.com/>

April 1998