

Roof Exhaust Fan Installation and Operation

Owner's Manual

PNEG-524



a division of

THE GSI GROUP

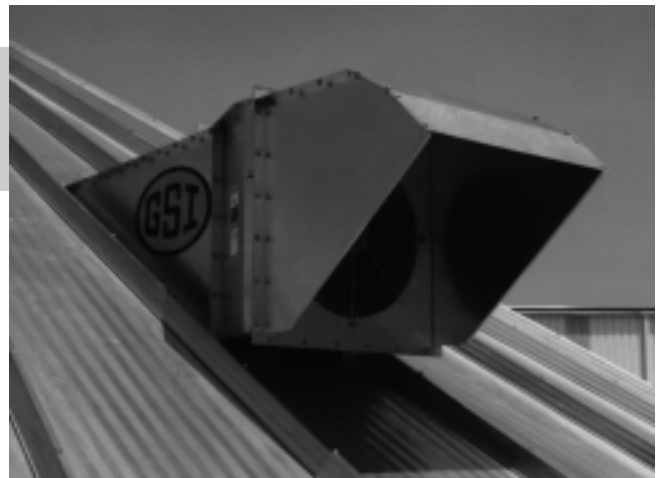

- _____ 1. All wire connections
- _____ 2. Tip clearance on blade
- _____ 3. Fan blade torqued to torque specs
- _____ 4. Grill guard in place and tight
- _____ 5. Motor rotation correct
- _____ 6. Running amperage
- _____ 7. Vibration
- _____ 8. All fasteners tight
- _____ 9. Indicator light
- _____ 10. All decals and serial number tag
- _____ 11. Aesthetic appearance
- _____ 12. Manual in control box
- _____ 13. Double check parts in hardware boxes

Tester Signature _____

Date _____

Roof Warning, Operation & Safety.....4

Safety Alert De-
cals.....5

Pre Installation.....6

 18" & 24" Roof Fan Package.....6

 Service Information.....6

Specifications.....7

 Fan Model Specifications For Roof Fans.....7

Installation Instructions.....8

 Roof Fan Description.....8

 18" And 24" Roof Fan Location.....8

 18" Roof Fan Mounting.....9

 24" Roof Fan Mounting And Assembly Of Fan, Adaptor And Rainhood.....10

 24" Roof Exhauster Reinforcement Kit.....12

 18" Roof Exhauster Parts.....13

 24" Roof Exhauster Parts.....14

Electrical Installation Instructions.....15

 Electrical Installation Of The Fan.....15

 Electrical Service For Single Phase Operation 230 Volt.....15

 Electrical Service For Three Phase Operation 230 Volt.....15

 Electrical Service For Three Phase Operation 460 Volt.....15

 Installation Check.....17

Operating Instructions18

 Before Starting Fan.....18

 Starting The Fan.....18

 Fan Shut Off.....18

 Off Season Operation And Maintenance.....18

 Fan Service.....18

Warranty.....20

ROOF DAMAGE WARNING AND DISCLAIMER



GSI DOES NOT WARRANT ANY ROOF DAMAGE CAUSED BY EXCESSIVE VACUUM OR INTERNAL PRESSURE FROM FANS OR OTHER AIR MOVING SYSTEMS. ADEQUATE VENTILATION AND/OR "MAKEUP AIR" DEVICES SHOULD BE PROVIDED FOR ALL POWERED AIR HANDLING SYSTEMS. GSI DOES NOT RECOMMEND THE USE OF DOWNWARD FLOW SYSTEMS (SUCTION). SEVERE ROOF DAMAGE CAN RESULT FROM ANY BLOCKAGE OF AIR PASSAGES. RUNNING FANS DURING HIGH HUMIDITY/COLD WEATHER CONDITIONS CAN CAUSE AIR EXHAUST OR INTAKE PORTS TO FREEZE.

ROOF EXHAUSTER FAN OPERATION

Thank you for choosing a GSI product. It is designed to give excellent performance and service for many years.

This manual describes the operation of the GSI Roof Exhaust Fan. It is designed to take in-bin air and expel it to the outside.

The principal concern of the GSI Group, Inc. ("GSI") is your safety and the safety of others associated with grain handling equipment. This

manual is written to help you understand safe operating procedures, and some of the problems that may be encountered by the operator or other personnel.

As owner and/or operator, it is your responsibility to know what requirements, hazards and precautions exist, and to inform all personnel associated with the equipment, or who are in the area. Avoid any alterations to the equipment. Such alterations may produce a very dangerous situation, where serious injury or death may occur.

SAFETY ALERT SYMBOL

The symbol shown is used to call your attention to instructions concerning your personal safety. Watch for this symbol; it points out important safety precautions. It means "ATTENTION", "WARNING", "CAUTION", and "DANGER". Read the message and be cautious to the possibility of personal injury or death.



WARNING! BE ALERT!

Personnel operating or working around electric fans should read this manual. This manual must be delivered with the equipment to its owner. Failure to read this manual and its safety instructions is a misuse of the equipment.

The GSI Group, Inc. recommends contacting your local power company, and having a representative survey your installation so the wiring is compatible with their system, and adequate power is supplied to your unit.

Safety decals should be read and understood by all people in the grain handling area. The bottom right decal should be present on the inside bin door cover of the two ring door, 24" porthole door cover and the roof manway cover.

If a decal is damaged or is missing contact:

The GSI Group, Inc.
 1004 E. Illinois St.
 Assumption, IL 62510
 217-226-4421

A free replacement will be sent to you.

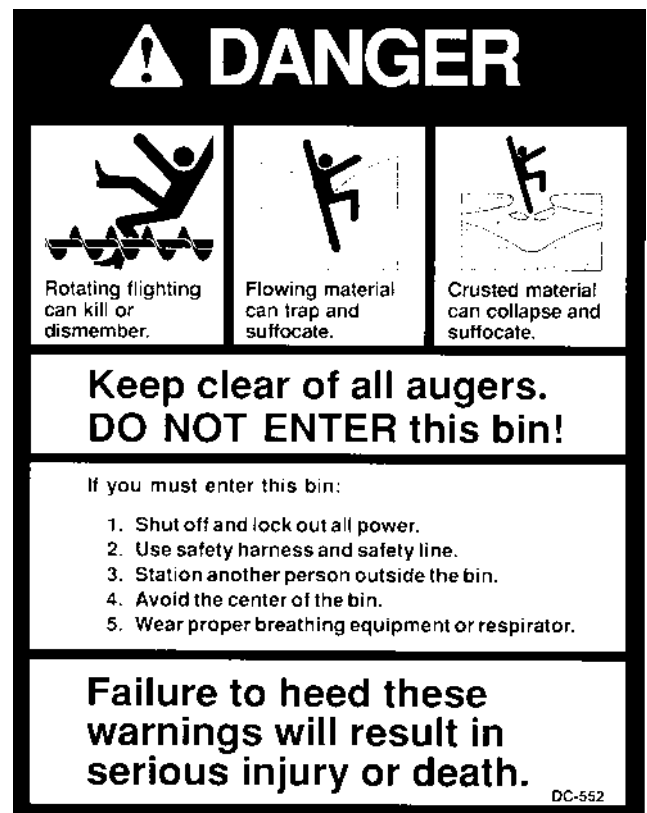

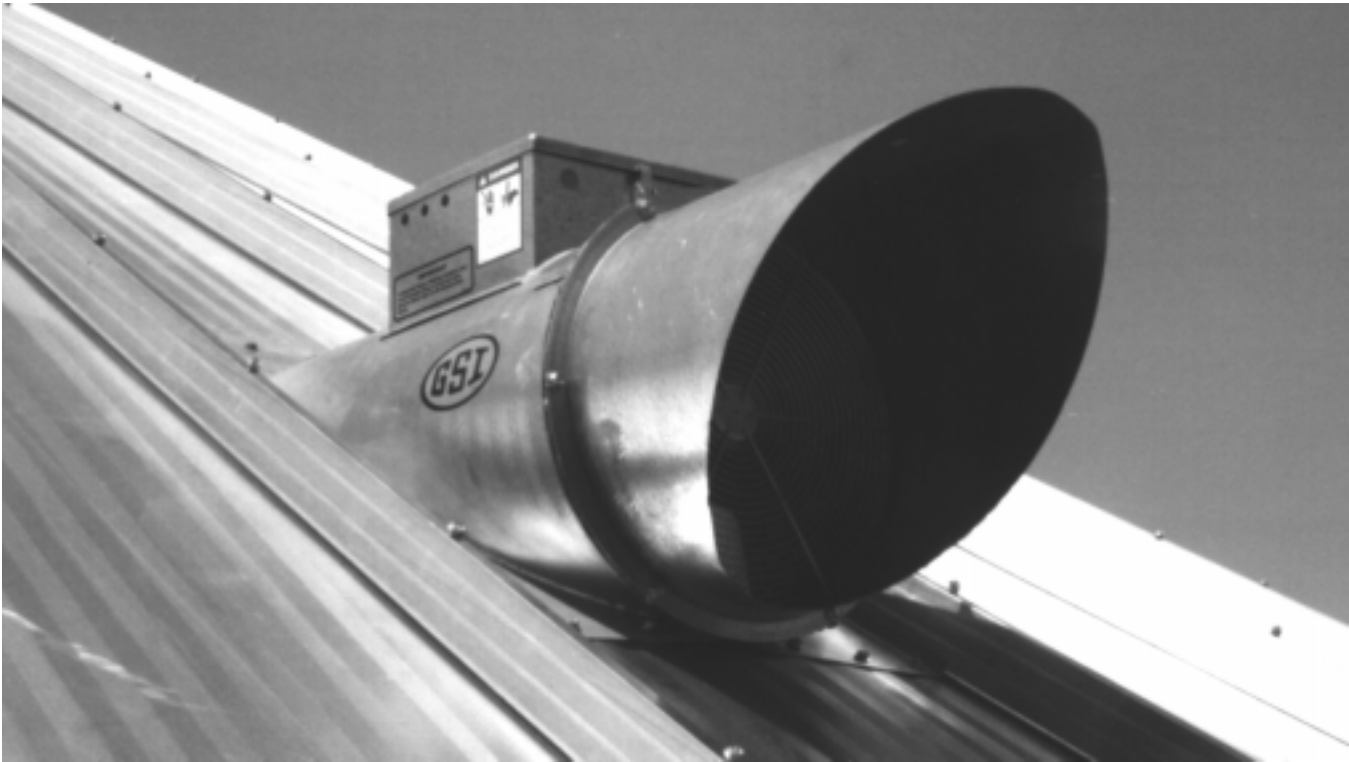

An 18" roof exhaust fan.

18" Roof Fan Package	24" Roof Fan Package
Roof fan assembly	Roof fan assembly
Bottom mounting flange	Manual PNEG-524
Hardware package	Fan housing top plate
Manual PNEG-524	Adaptor-top,right & left side
	Rainhood top, right & left side
	Hardware package
	(4) Template parts

Your model package should contain items shown in the chart at the left. **Note:** Before starting the assembly and installation of the roof exhaust fan, check to see that all items called out on the packing list have been received. In case there are any shortages, contact your dealer. If there is any damage during shipment, file a claim with the carrier.

SERVICE INFORMATION

Fan model number _____
Fan serial number _____
Bin diameter _____
Grain type _____
Grain depth _____
Line voltage (measured) _____
Dealer purchased from _____
Date purchased _____

Fill in the information here for your records. If you have a question regarding your roof exhaust fan, contact the dealer from whom you purchased the unit. If he is unable to answer your question, refer to the factory. This information must be available before contacting the dealer or factory, if service is ever needed.

Fan Model Specifications For Roof Fans

Fan model number	Fan H. P.	Motor Phase & Voltage	Motor Type	R. P. M.	Blade Diameter	Unit Amperage Max.
MIS-6685-1	.5	single-115/230V	TEAO	1750	18"	7.2/3.6
MIS-6685-3	.5	three-230V	TEAO	1750	18"	1.8
MIS-6685-4	.5	three-460V	TEAO	1750	18"	.9
MIS-6685-1E	.5	single-230V	EX PRF	1750	18"	4.0
MIS-6685-3E	.5	three-230	EX PRF	1750	18"	2.0
MIS-6685-4E	.5	three-460V	EX PRF	1750	18"	1.0
MIS-6675-1	2	single-115/230V	TEAO	1750	24"	18.6/9.3
MIS-6675-3	2	three-230	TEAO	1750	24"	8.2
MIS-6675-4	2	three-460V	TEAO	1750	24"	4.1
MIS-6675-1E	2	single-115/230V	EX PRF	1750	24"	18.6/9.3
MIS-6675-3E	2	three-230	EX PRF	1750	24"	8.2
MIS-6675-4E	2	three-460V	EX PRF	1750	24"	4.1

All single phase motors and the .5 H. P. explosion proof three phase motor are supplied with automatic overload protection. The remaining three phase motors do not have internal motor protection.

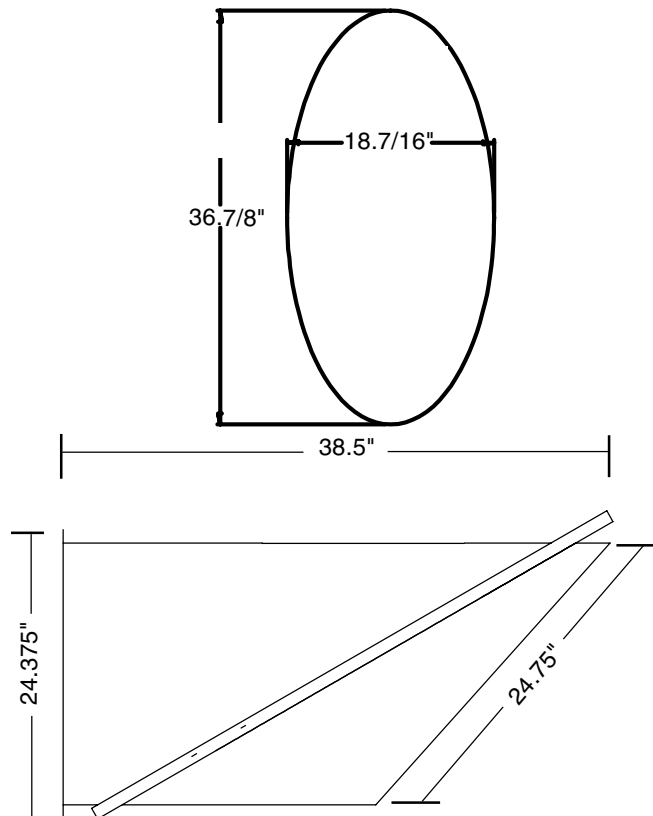

Figure 1: Open area dimensions and 18" .5 H. P. roof fan exhauster sideview illustration.

Motors rated as explosion proof (EX PRF) meet class II group F & G of the National Electric Code (NEC).

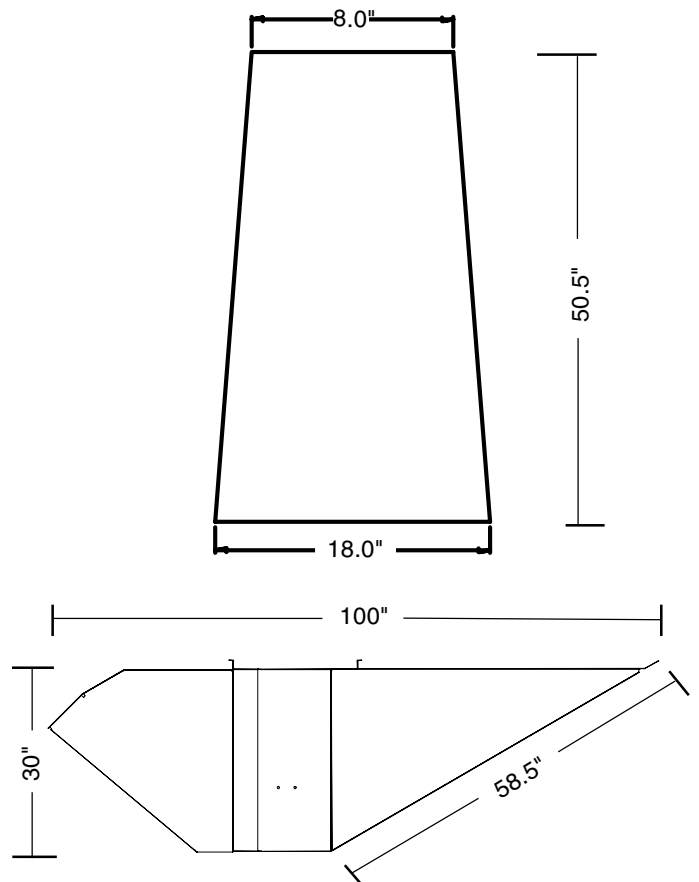

Figure 2: Open area dimensions and 24" 2 H. P. roof fan exhauster sideview illustration.

Standard electrical safety practices and codes should be used when working with a fan. Refer to the National Electric Code Standard Handbook by the National Fire Protection Association. *A qualified electrician should make all wiring installations.*



**ALWAYS DISCONNECT
AND LOCK OUT POWER
BEFORE WORKING ON
OR AROUND FAN**

Roof Fan Description

GSI roof exhaust fans are designed to mount on structures with sloping roofs, and with a flat roof surface at least as large as illustrated in Figures 1 and 2. The fans will mount between the ribs of standard tapered roof sheets on round steel bins without cutting the ribs, which keeps the strength of the roof sheet intact. The 18" .5 H. P. roof fan is shipped completely assembled, and will mount on a roof slope of 30 degrees. The 24", 2 H. P. roof fan is shipped with the roof adaptor and rainhood unassembled, and it is also designed to mount on a 30 degree roof slope.

18" And 24" Roof Fan Location

The roof fans should be equally spaced on the bin roof circumference. When installed, the roof fan should be positioned as far up the roof slope as the tapered ribs of the bin roof sheet will allow.

The roof fan location should be selected to provide a rigid mounting for the fan. For bins with an inner roof structure, the roof fan should be anchored to the inner roof structure.

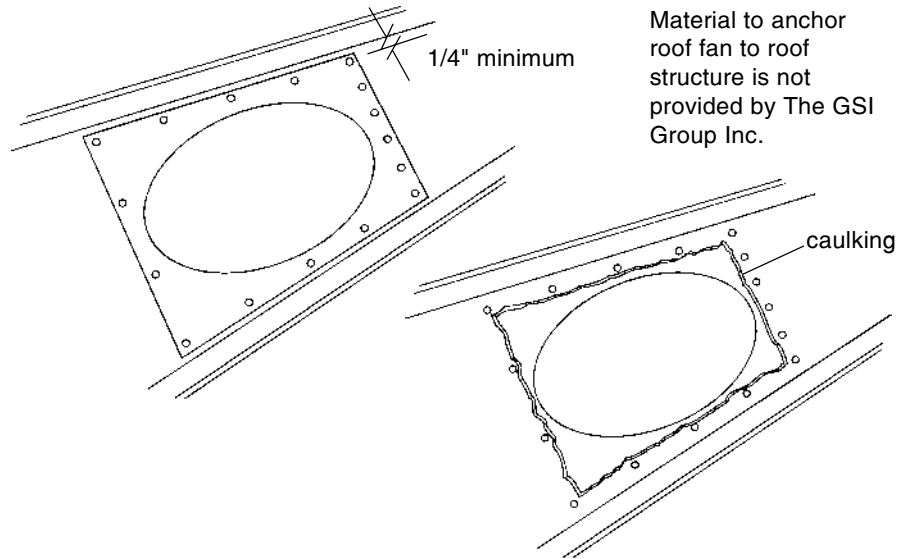

Figure 3: The 18" template location on the roof sheet (left), and the caulking location on the roof sheet (right).

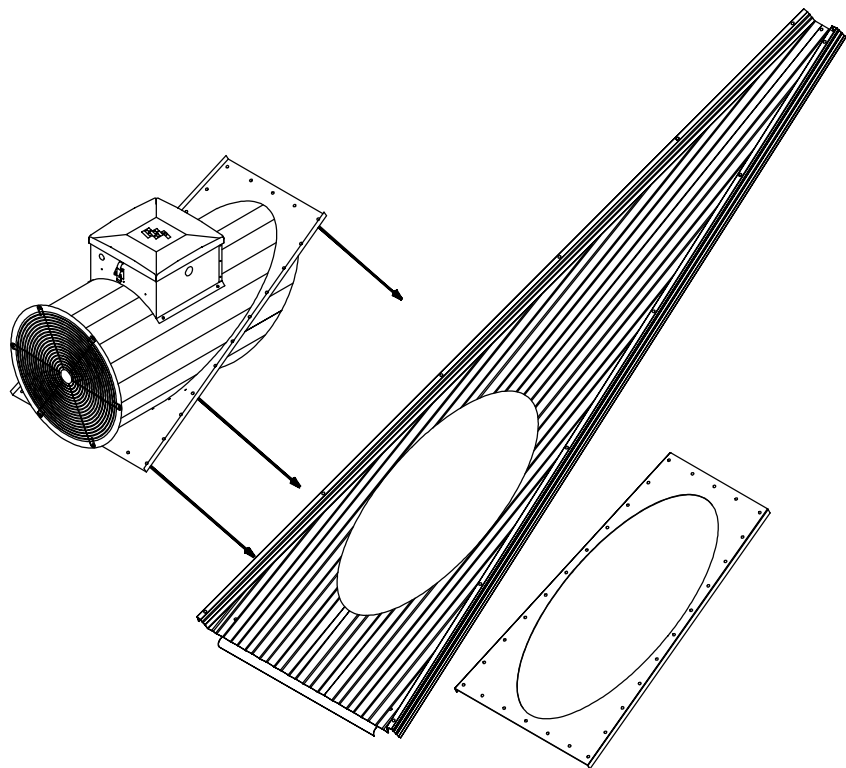

Figure 4: The 18" roof exhauster fan in relation to the roof sheet.

18" Roof Fan Mounting

The roof fan can be installed in the roof sheet before assembling the roof, or after the roof is assembled. **Locate roof fan so that inner roof structure does not interfere with installation.** The fan is secured by bolts that must be fastened from the inside of the bin roof, and therefore the assembly should be made before the side walls are erected.

1. Using the loose flange from the fan assembly as a template, position the desired roof fan location, allowing for 1" minimum between the roof sheet rib and the flange. See figure 3. Mark the sixteen(16), 3/8" mounting holes, and elliptical fan mounting hole.
2. Drill the sixteen(16), 3/8" holes and cut out the elliptical hole. Use the caulk provided, which is specified as a seal for metal sheets in an outdoor application, and apply along the inside edge of the drilled holes on the bin roof sheet. See figure 3.
3. Place the roof fan into the elliptical hole from the outside of the roof sheet inward. On the side of the roof sheet that will be inside the bin, position the loose mounting flange over the fan tube. Using the sixteen (16) 5/16" x 3/4" bin bolts with the neoprene washer head to the outside of the bin, secure the fan, roof sheet and flange with the 5/16" nuts provided. See figure 4.

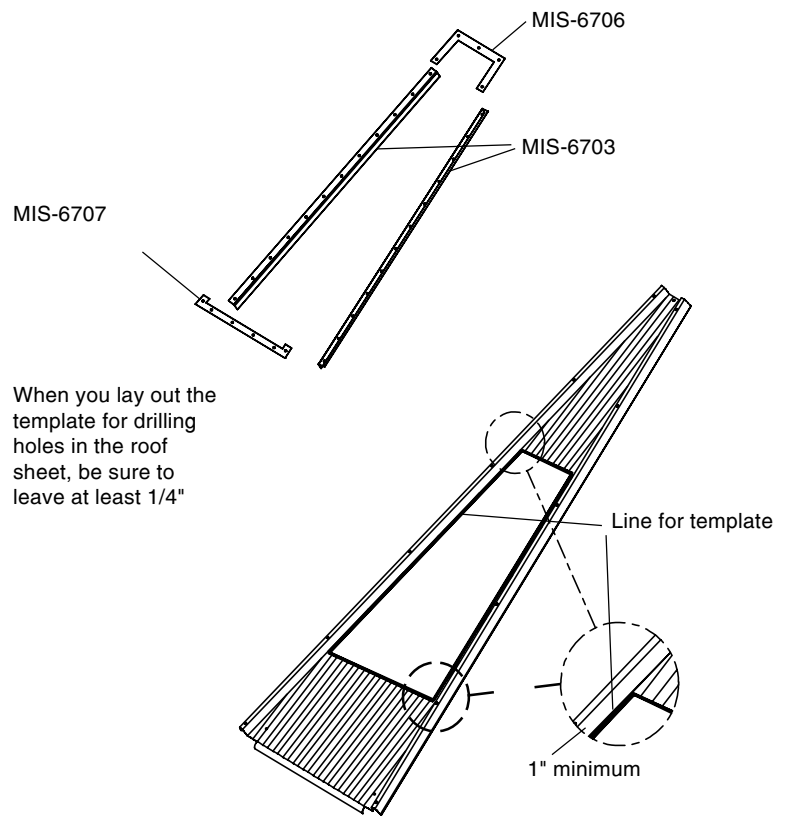

Figure 5: 24" roof fan template placement on the roof sheet.

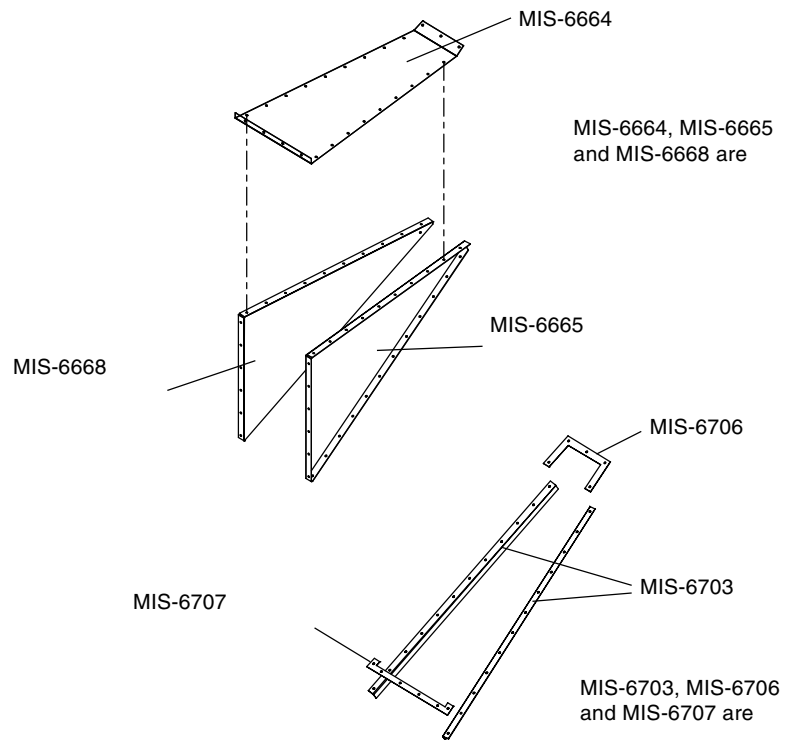

Figure 6: 24" roof fan adaptor and template parts breakdown.

24" Roof Fan Mounting And Assembly Of Fan, Adaptor And Rainhood

The roof fans, adaptor and rainhood can be installed in the bin roof sheet before assembling the roof or after the roof is assembled. The fan is secured by bolts that must be fastened from the inside of the bin roof, so the assembly should be made before the sidewalls are erected.

1. Assemble the roof sheet mounting template as shown in figure 5.
2. Place the roof sheet adaptor mounting template at the appropriate location of the roof fan. Move the template as far up the roof sheet as possible, but allow for 1" minimum clearance between the roof sheet rib and bottom of the template on each side.
3. Drill two corner holes and bolt template in place.
4. Drill the remaining 11/32" mounting holes identified on the template.

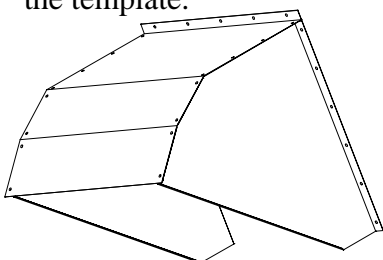

Figure 7: The rainhood preassembly.

5. Mark a cutting line 3/4" inside the template. Then remove template. Drill through the mark, cutting a hole in the roof sheet. See figure 8.
6. Preassemble the adaptor section parts of the roof fan. Loosely bolt the adaptor left side and right side to adaptor top. On all components, bolts are to be installed with the head on the fan housing exterior.
7. Caulk along the bolt hole line where the adaptor flange will mount to the roof sheet.

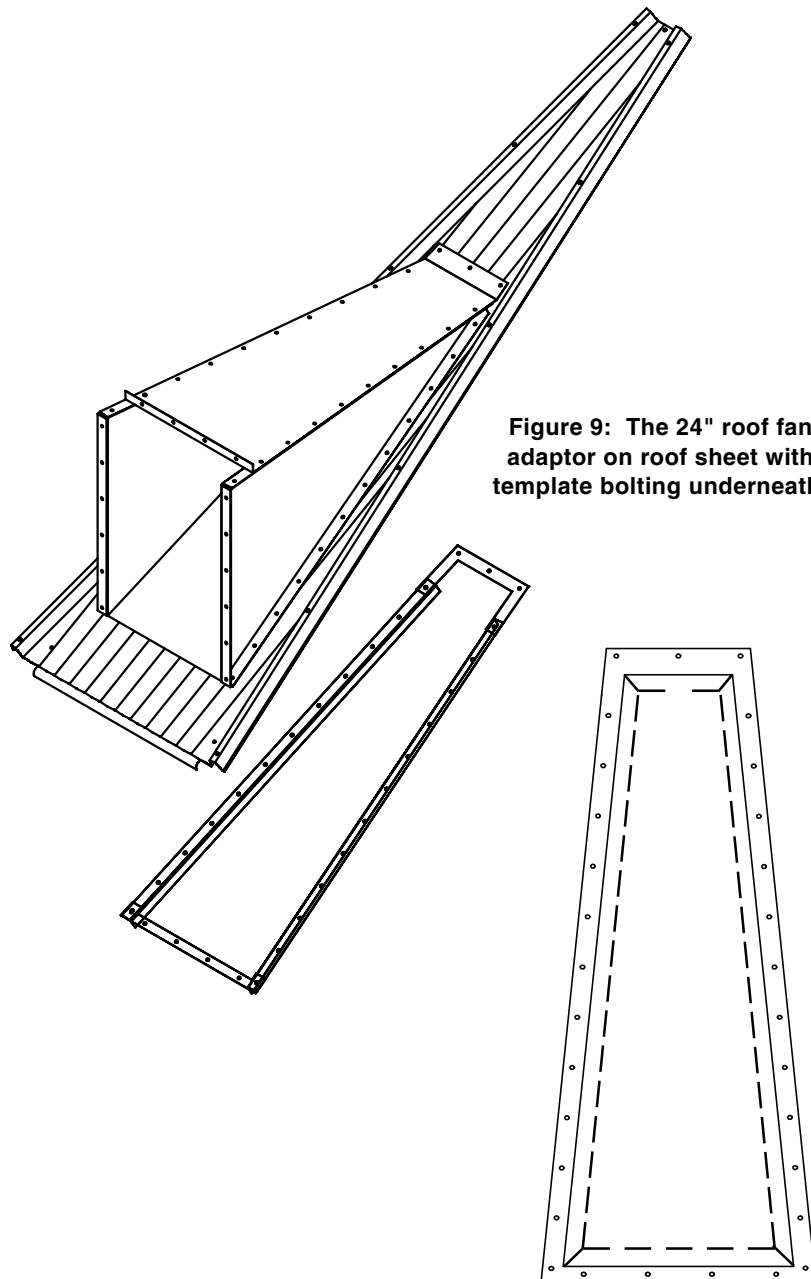

Figure 9: The 24" roof fan adaptor on roof sheet with template bolting underneath.

Figure 8: The cutline for roof sheet adaptor.

24" Roof Fan Monting and Assembly of Fan, Adaptor and Rainhood, continued

8. Bolt the adaptor section to the roof sheet along with the support angles MIS-6703 (template) under the roof sheet, See figure 9. Tighten the adaptor to the roof sheet with template bolts.

9. Form a lip up around the inside of the adaptor opening by peening up the edge of the roof sheet extending past the inner edge of the roof adaptor.

10. Loosely bolt the rainhood top plate, rainhood right side and rainhood left side together.

11. Bolt the fan housing to the adaptor. See figure 10.

12. At this time the optional 90° deflector may be preassembled.

13. Bolt deflector assembly to MIS6674 sub-assembly for noise deflection. See figure 11.

14. Bolt rainhood to fan housing or optional 90° deflector if installed.

15. Support optional 90° deflector adequately down to bin roof structure to prevent exhauster or

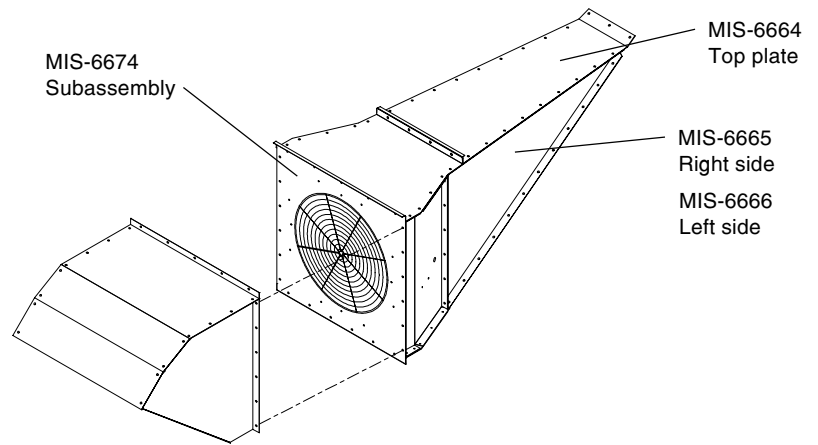

Figure 10: The 24" roof fan exhauster and rainhood.

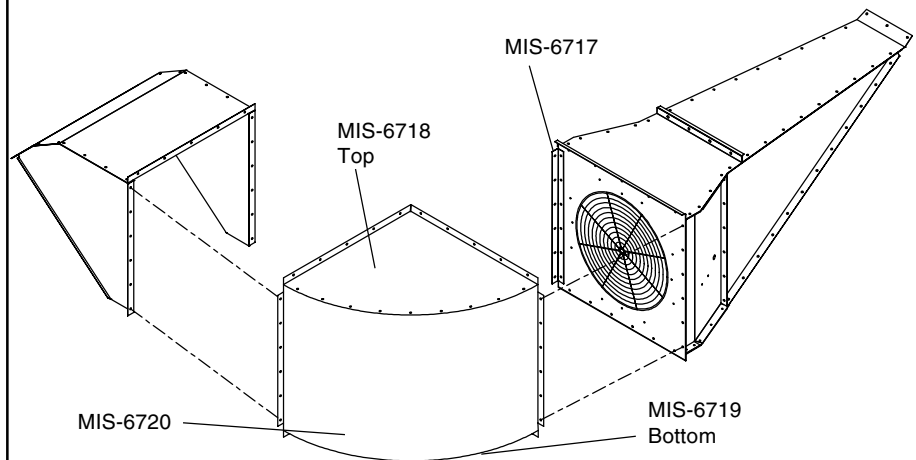
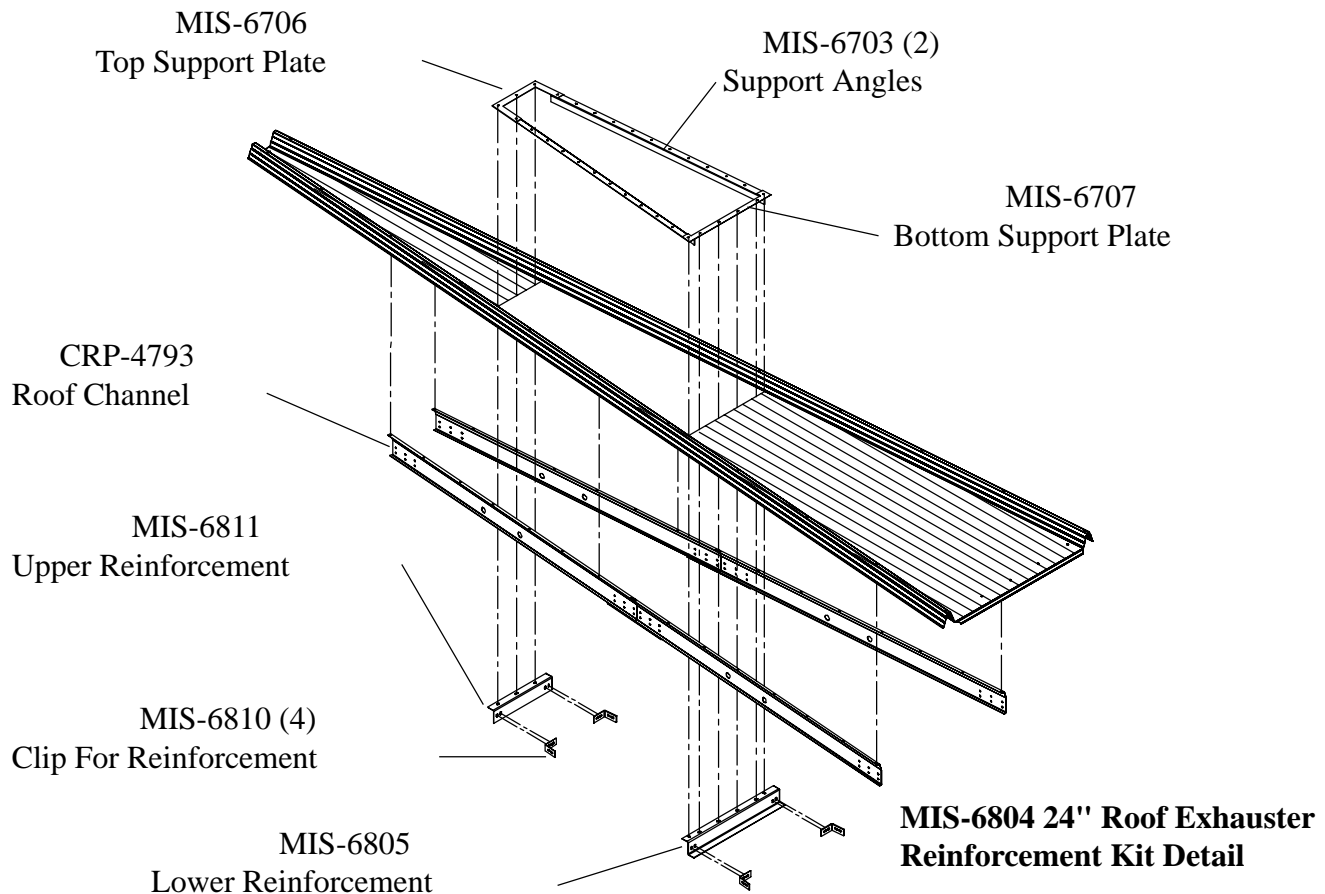

Figure 11: The 24" roof fan exhauster with optional 90° deflector.

roof damage due to flexure of deflector and exhauster.

16. The roof fan location should be selected to provide a rigid mounting for the fan. For bins with an inner roof structure, the roof fan should be anchored to the inner roof structure.

17. The fan housing top plate is provided for access to the motor for electrical installation, and a knock out is provided in the fanside for the wire access. Depending on when you have your electric connections made, the motor could be wired before step 12, or the fan could be wired later by removing the fan housing top plate.



1. Reference page 10 for the 24" roof adaptor template and mounting, and the 30° Roof Manual PNEG-030 for the roof channel assembly.
2. Install the roof support channels in the ribs of the upper panel where the exhauster is to be mounted.
3. Install the template and cut exhauster parts as specified on page 10.
4. Utilize the upper MIS-6811 and lower MIS-6805 reinforcement supports to support the exhauster. Mount reinforcement under the top support plate MIS-6706 and bottom support plate MIS-6707 on the bottom surface of the roof panel.
5. After placing the supports, field drill the attachment clip at the required locations in channels CRP-4793.
6. Some field cutting or bolting of components may be necessary due to variables in the roof exhauster mounting equipment.
7. The MIS-6804 is designed primarily around mounting into the upper roof of a GSI commercial bin/silo. Field fabrication of supports may be necessary in other brands of bins/silos.
8. A pair of adjustable brace assemblies are included in this kit to brace the exhauster unit to the roof ribs on the upper side of the roof. Attach the brace to the roof exhauster unit and then attach the other end to a roof rib (via a 5/16" bolt). This should attach to the exhauster near the rainhood mounting angle point.
9. The adjustable brace consists of one center tube (LS-6615) and two end tubes (LS-6616). The end tubes go inside the center tube and attach one end tube to the top of the extension rail. Adjust the other end tube so the bottom of the flattened tube reaches the roof rib. Field drill four 5/16" holes through both center and end tubes and bolt together using 1/4" x 1.1/2" bolts and nuts. This will keep the adjustable brace from slipping.

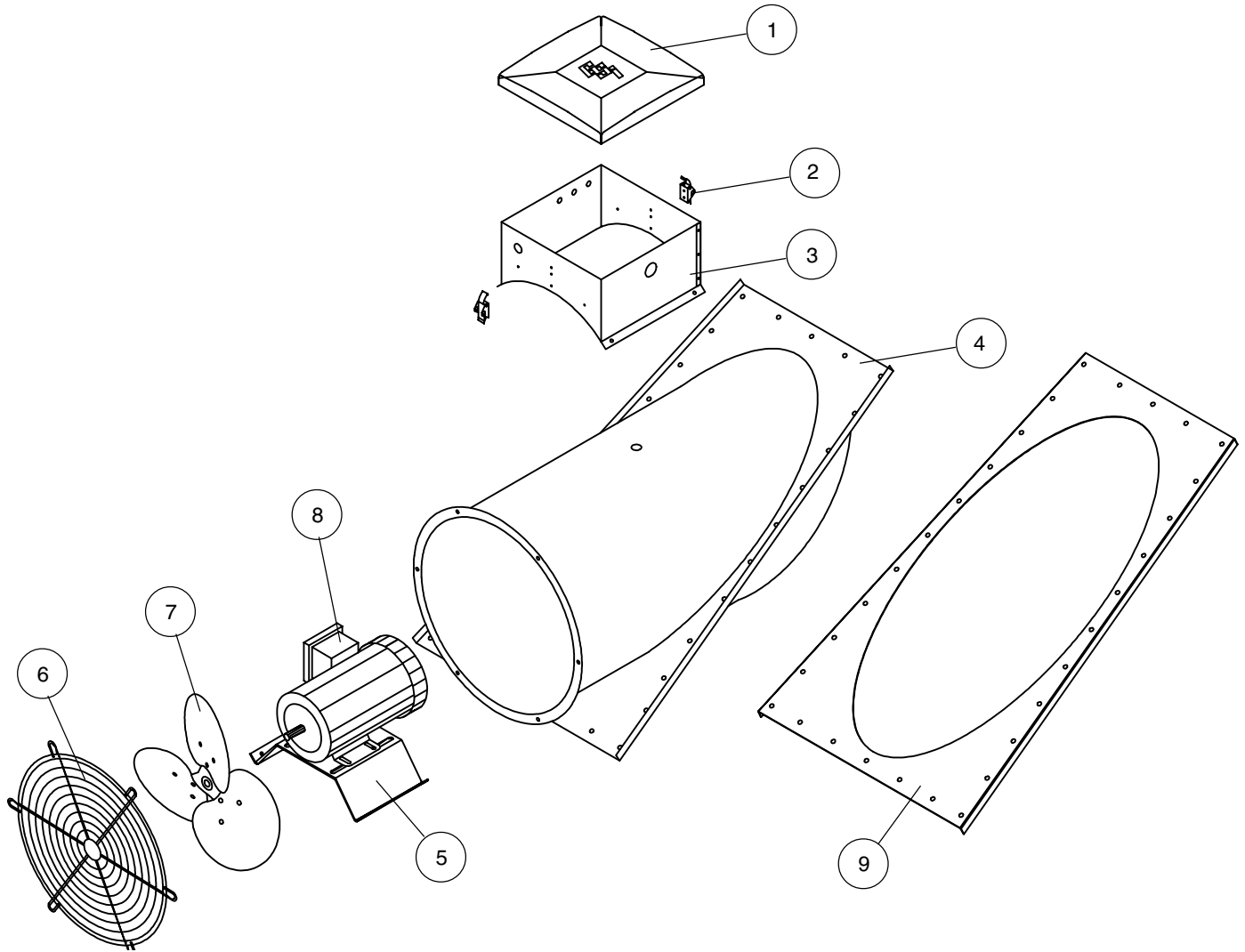
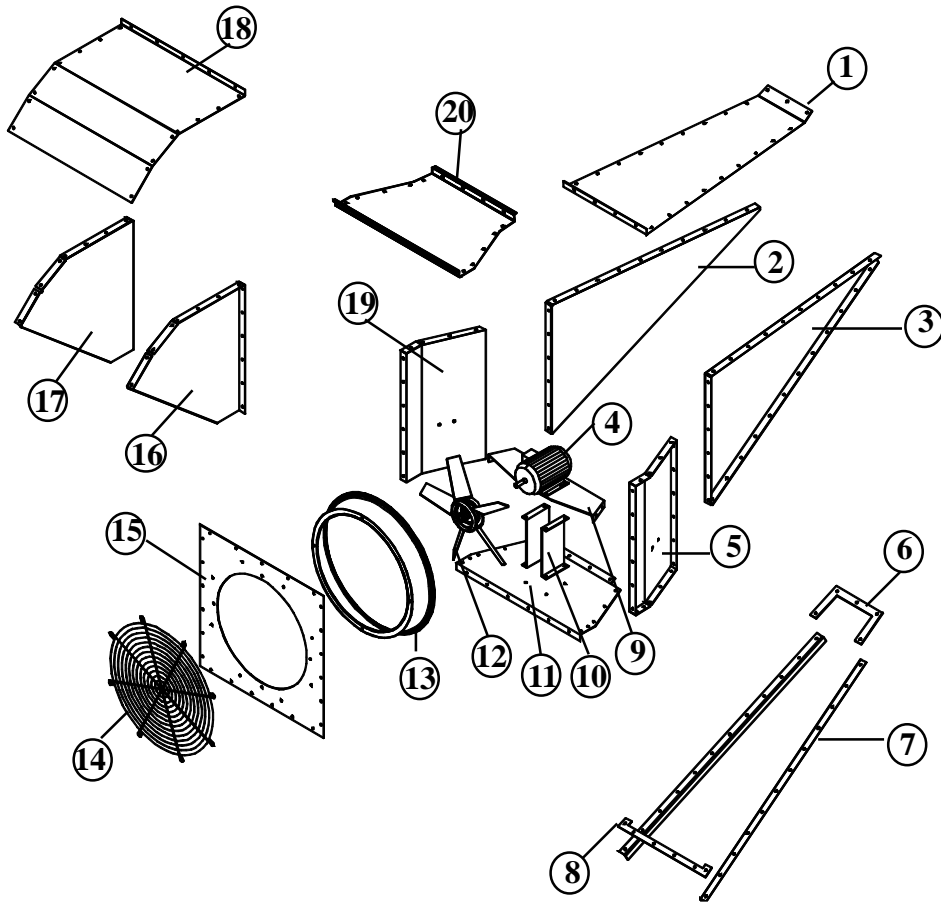

Figure 12: 18" roof exhauster parts breakdown.

18" ROOF EXHAUSTER PARTS

Reference Number	Part Number	Description	Quantity
1	F-942	Control box lid	1
2	FH-4429-1	Lid clamp	2
3	F-6864	Control box wrapper	1
4	MIS-6680	18" exhauster weldment	1
5	F-6701	Motor support bracket	1
6	F-953	Fan grill guard	1
7	MIS-6689	18" fan blade	1
8	MIS-6688	.5 H. P. motor	1
9	MIS-6679	Mounting Flange	1



24" ROOF EXHAUSTER PARTS

Reference Number	Part Number	Description	Quantity
1	MIS-6664	Adaptor top plate	1
2	MIS-6666	Exhauster adaptor left panel	1
3	MIS-6665	Exhauster adaptor right panel	1
4	MIS-6686	2 H. P. motor	1
5	MIS-6660	Exhauster housing right side	1
6	MIS-6706	Top support plate	1
7	MIS-6703	Support angles	2
8	MIS-6707	Bottom support plate	1
9	MIS-6671	Motor support plate	1
10	MIS-6672	Motor support channels	2
11	MIS-6670	Support plate	1
12	MIS-6687	24" fan blade	1
13	TFH-2016	Venturi	1
14	F-954	Fan grill guard	1
15	MIS-6662	Venturi mounting plate	1
16	MIS-6667	Weather hood right panel	1
17	MIS-6668	Weather hood left panel	1
18	MIS-6669	Weather hood top	1
19	MIS-6659	Exhauster housing left side	1
20	MIS-6663	Exhauster housing top plate	1

Electrical Installation Of The Fan

The electrical installation must be performed by a certified electrician in accordance with the appropriate national and local electrical codes.

CAUTION! ANY VIOLATION OF ELECTRICAL WIRING CODES COULD JEOPARDIZE THE AIRSTREAM WARRANTY.

Check the type of electrical service present, and make sure the fan to be wired is manufactured to operate on the electrical service. The table on page 7 entitled "Fan Model Specifications" indicates the electrical service the fan is designed to utilize in the column labeled "Motor Phase and Voltage". The electrical service must match this specification.

The components to connect the electrical ser-

vice to the fan need to be sized for the electrical service present. The charts below illustrate the sizing information for single phase 230 volt, three phase 230 volt and 460 volt respectively. Use the appropriate information and size the following electrical service components:

1. Transformer

The transformer size for the fan only is indicated in a KVA rating. Example: For a 24" fan the first chart would be used. The KVA rating for the 2 horse power motor is 3.5 KVA. This KVA rating is for the fan only. Your electrician will need to add the KVA requirements for the other electrical components of the system in sizing the transformer.

Electrical Service For Single Phase Operation 230 Volt

Motor H. P. Range	Transformer Size (Note B) (Minimum)	Copper Wire Size for Distance-Motor to Disconnect in Feet up to:				Fusetron or Equivalent Time Delay Fuse AMP
		0'-50'	100'	200'	300'	
0.5 2.0	1.0 KVA 3.5 KVA	14 12	14 10	12 6	10 5	10 30

Electrical Service For Three Phase Operation 230 Volt

Motor H. P. Range	Transformer Size (Note B) (Minimum)	Copper Wire Size for Distance-Motor to Disconnect in Feet up to:				Fusetron or Equivalent Time Delay Fuse AMP
		0'-50'	100'	200'	300'	
0.5 2.0	1.0 KVA 3.5 KVA	14 14	14 12	14 10	14 8	10 15

Electrical Service For Three Phase Operation 460 Volt

Motor H. P. Range	Transformer Size (Note B) (Minimum)	Copper Wire Size for Distance-Motor to Disconnect in Feet up to:				Fusetron or Equivalent Time Delay Fuse AMP
		0'-50'	100'	200'	300'	
0.5 2.0	1.0 KVA 3.5 KVA	14 14	14 14	14 12	14 12	10 10

2. Fan Disconnect

A disconnect for the fan needs to be sized to handle the recommended fusetron size. Example: For a 24" fan the first chart on page 14 would be used, and the fusetron size is 30 AMP. Install the fusetron recommended in the disconnect. A circuit breaker can be used, however, the circuit breaker or any fuse used must be a time delay type to allow the initial starting inrush current to the fan.

3. Conductor size for the fan disconnect to fan wiring

The conductor size for the fan needs to be sized according to the distance between the fan and disconnect. Example: For a 24" fan located 200' from the disconnect use the first chart on page 14 to determine the conductor size to be a 14 AWG. The proper size wiring must be used to make sure a voltage drop does not occur.

4. Fan Motor Controller

Size the fan motor controller according to the motor ratings for a convenient control location as follows:

Motors with internal overload protection will require a magnetic contactor to control fan operation.

Motors without overload protection will require a magnetic starter with overload protection to control fan operation.

5. Single Phase

A 3-wire system should be provided for fans to be operated on single phase power. The three wires consist of the two current conductors and a ground. The current carrying conductors are wired per the diagram on the motor. The ground is secured to the motor frame. On 2 H.P. explosion proof motors thermostat wires are provided with the motor, and must be connected to the fan motor magnetic controls.

6. Three Phase

A 4-wire system should be provided for fans to be operated on three phase power. The four wires consist of three current carrying conductors, and a ground. The current carrying conductors are wired per the diagram on the motor. The ground is secured to the motor frame. On 2 H.P. explosion proof motors thermostat wires are provided with the motor, and must be connected to the fan motor magnetic controls.

When installing electrical service for explosion proof motors make sure all conduit and connectors exposed to the conditions of the motor are rated for the Class II group F and G location of the motor.

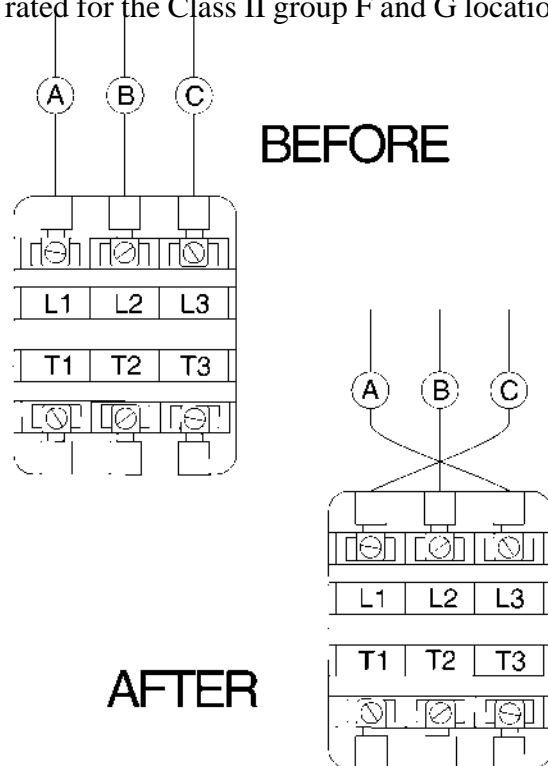

Figure 14: Correcting the fan rotation for three phase.

Installation Check

When the fan is completely assembled and wired the unit needs to be checked for proper rotation. Provide power to the fan controls and start the fan momentarily. Make sure the fan blade rotates to exhaust air from the bin. If the blade is rotating the wrong direction, have your electrician correct as follows:

1. Single Phase System

With the power OFF at the fan disconnect, the motor lead wires at the fan motor need to change as indicated on the motor to reverse the blade rotation. The unit then needs to be rechecked for proper rotation.

2. Three Phase System

With the power OFF at the fan disconnect, exchange the location of the current carrying con-

ductors at terminal L1 and L3 (figure 14) of the magnetic controls. The unit will then need to be rechecked for proper rotation.

Always check current local, state and national codes on electrical requirements before installing any electrical equipment.

Transformer size is based on the current draw from the fan only. Your electrician will need to add the KVA requirements for the other components of the system in sizing the transformer.

Copper wire (rated 75°F) is sized for the fan service. The wire size from the transformer to the disconnect service will be determined from the fan, and the other electrical equipment requirements.

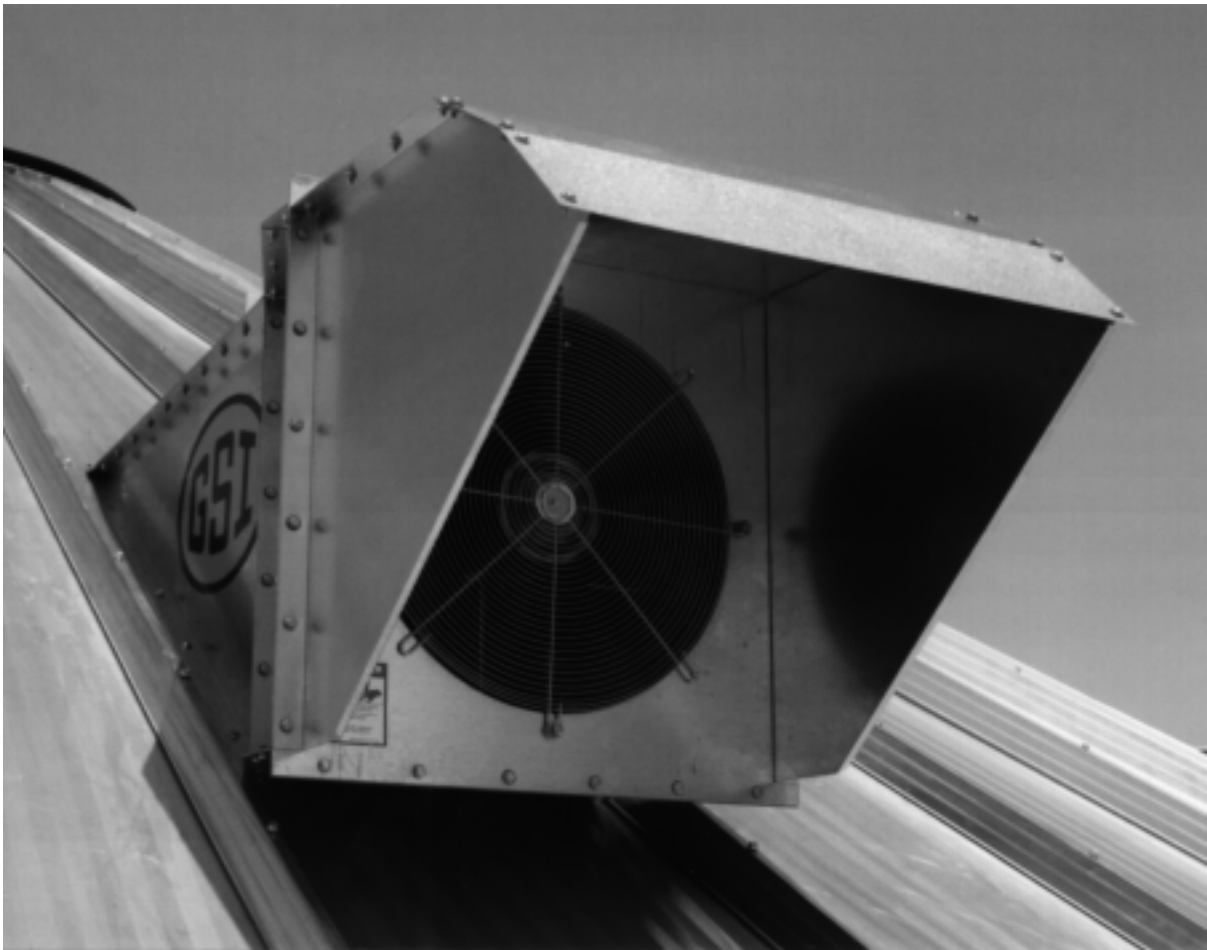

24" roof fan exhauster with the rainhood in place.

Before Starting Fan

When starting the fan for the first time, check the following:

1. With the power OFF, rotate the fan blade to make sure it revolves easily, and does not rub on the venturi or fan tube.
2. Check all the fasteners to make sure they are tight. If any are loose, check for proper clearance and retighten.
3. With the power OFF, check all electrical connections to make sure they are tight. Inspect the current carrying wires to make sure they are not grounded. Make sure the fan and disconnect are grounded. All control enclosure covers and access doors should be secured in place.
4. Refer to the wiring diagram on the motor, and make sure the motor is wired correctly.

Starting The Fan

The roof exhaust fans should operate anytime the supply fans operate. The roof fans can operate independently of the supply fans just to provide ventilation of the attic space, but this requires that vents be used in the roof to provide an open area.

18" fan.....4 square feet per fan
24" fan.....10 square feet per fan

Fan Shut Off

When shutting the fan down for the season, shut off the power at the fan disconnect rather than at the fan controls to provide additional protection from unauthorized personnel operating the fan, and potential damage to the fan from a lightning strike.

Off Season Operation And Maintenance

During the off season, the fan blade should be allowed to turn freely. The fan should operate for approximately 30 minutes every three weeks. This keeps the fan lubricant more evenly distributed within the bearing cavity, and dries out any condensation that could be in the motor.

Fan Service

When servicing the fan, switch power OFF at the fan disconnect switch. Activate power only when a check is made. The following items will help you to pinpoint a possible malfunction of the fan unit and explain the corrective action to take.

If the motor controller is turned on and nothing happens, check the following:

1. Make sure power is available to the fan unit.
2. Check the motor thermostat (if present) to determine if the thermostat is open or closed. If the thermostat is open, take the motor to your local authorized service center. When checking the thermostat, make sure the motor has time to cool, if hot.

3. If power is available to the motor and it does not run, remove the motor and take it to an authorized motor service center for repair or replacement.

If the fan just hums when turned on, check the following:

1. Check to make sure that all leads of your power source have voltage present. If fan unit is not receiving power on all leads, check for a blown fuse, broken wire or loose connection.
2. Check to see that all contact sets are closing. If one leg of the supply voltage is not available to the motor it will hum.
3. If power is available at all motor leads, and the motor still hums, it should be taken to an autho-

rized service center for repair or replacement.

If the fan starts and operates for awhile and then shuts off, check the following:

1. Check the supply voltage. Voltage should be within +/-10% of rated voltage. For example, a motor rated at 230 volt should operate in a voltage range of 207 to 253 volt.
2. Check the supply wire size required for the fan unit.
3. Check the load on the main circuit to make sure other items on it are not overloading the fan circuit.
4. Check the amperage of the fan, if the unit is pulling above name plate amperage, take the motor to an authorized service center.

THE GSI GROUP, INC. ("GSI") WARRANTS ALL PRODUCTS MANUFACTURED BY GSI TO BE FREE OF DEFECTS IN MATERIAL AND WORKMANSHIP UNDER NORMAL USAGE AND CONDITIONS FOR A PERIOD OF 12 MONTHS AFTER RETAIL SALE TO THE ORIGINAL END USER OF SUCH PRODUCTS. GSI'S ONLY OBLIGATION IS, AND PURCHASER'S SOLE REMEDY SHALL BE FOR GSI, TO REPAIR OR REPLACE, AT GSI'S OPTION AND EXPENSE, PRODUCTS THAT, IN GSI'S SOLE JUDGMENT, CONTAIN A MATERIAL DEFECT DUE TO MATERIALS OR WORKMANSHIP. ALL DELIVERY AND SHIPMENT CHARGES TO AND FROM GSI'S FACTORY WILL BE PURCHASER'S RESPONSIBILITY. EXPENSES INCURRED BY OR ON BEHALF OF THE PURCHASER WITHOUT PRIOR WRITTEN AUTHORIZATION FROM AN AUTHORIZED EMPLOYEE OF GSI SHALL BE THE SOLE RESPONSIBILITY OF THE PURCHASER.

EXCEPT FOR THE ABOVE STATED EXPRESS LIMITED WARRANTIES, GSI MAKES NO WARRANTY OF ANY KIND, EXPRESSED OR IMPLIED, INCLUDING, WITHOUT LIMITATION, WARRANTIES OF MERCHANTABILITY OR FITNESS FOR A PARTICULAR PURPOSE OR USE IN CONNECTION WITH (i) PRODUCT MANUFACTURED OR SOLD BY GSI OR (ii) ANY ADVICE, INSTRUCTION, RECOMMENDATION OR SUGGESTION PROVIDED BY AN AGENT, REPRESENTATIVE OR EMPLOYEE OF GSI REGARDING OR RELATED TO THE CONFIGURATION, INSTALLATION, LAYOUT, SUITABILITY FOR A PARTICULAR PURPOSE, OR DESIGN OF SUCH PRODUCT OR PRODUCTS.

IN NO EVENT SHALL GSI BE LIABLE FOR ANY DIRECT, INDIRECT, INCIDENTAL OR CONSEQUENTIAL DAMAGES, INCLUDING, WITHOUT LIMITATION, LOSS OF ANTICIPATED PROFITS OR BENEFITS. PURCHASER'S SOLE AND EXCLUSIVE REMEDY SHALL BE LIMITED TO THAT STATED ABOVE, WHICH SHALL NOT EXCEED THE AMOUNT PAID FOR THE PRODUCT PURCHASED. THIS WARRANTY IS NOT TRANSFERABLE AND APPLIES ONLY TO THE ORIGINAL PURCHASER. GSI SHALL HAVE NO OBLIGATION OR RESPONSIBILITY FOR ANY REPRESENTATIVE OR WARRANTIES MADE BY OR ON BEHALF OF ANY DEALER, AGENT OR DISTRIBUTOR OF GSI.

GSI ASSUMES NO RESPONSIBILITY FOR FIELD MODIFICATIONS OR ERECTION DEFECTS WHICH CREATE STRUCTURAL OR STORAGE QUALITY PROBLEMS. MODIFICATIONS TO THE PRODUCT NOT SPECIFICALLY COVERED BY THE CONTENTS OF THIS MANUAL WILL NULLIFY ANY PRODUCT WARRANTY THAT MIGHT HAVE BEEN OTHERWISE AVAILABLE.

THE FOREGOING WARRANTY SHALL NOT COVER PRODUCTS OR PARTS WHICH HAVE BEEN DAMAGED BY NEGLIGENT USE, MISUSE, ALTERATION OR ACCIDENT. THIS WARRANTY COVERS ONLY PRODUCTS MANUFACTURED BY GSI. THIS WARRANTY IS EXCLUSIVE AND IN LIEU OF ALL OTHER WARRANTIES EXPRESS OR IMPLIED. GSI RESERVES THE RIGHT TO MAKE DESIGN OR SPECIFICATION CHANGES AT ANY TIME.

PRIOR TO INSTALLATION, PURCHASER HAS THE RESPONSIBILITY TO RESEARCH AND COMPLY WITH ALL FEDERAL, STATE AND LOCAL CODES WHICH MAY APPLY TO THE LOCATION AND INSTALLATION.



a division of

THE GSI GROUP



1004 E. Illinois St.
Assumption, IL
62510
phone 217-226-4421
fax 217-226-4498

June 1998