

1 9 9 5

DRYER PARTS

3300 SERIES THREE FAN

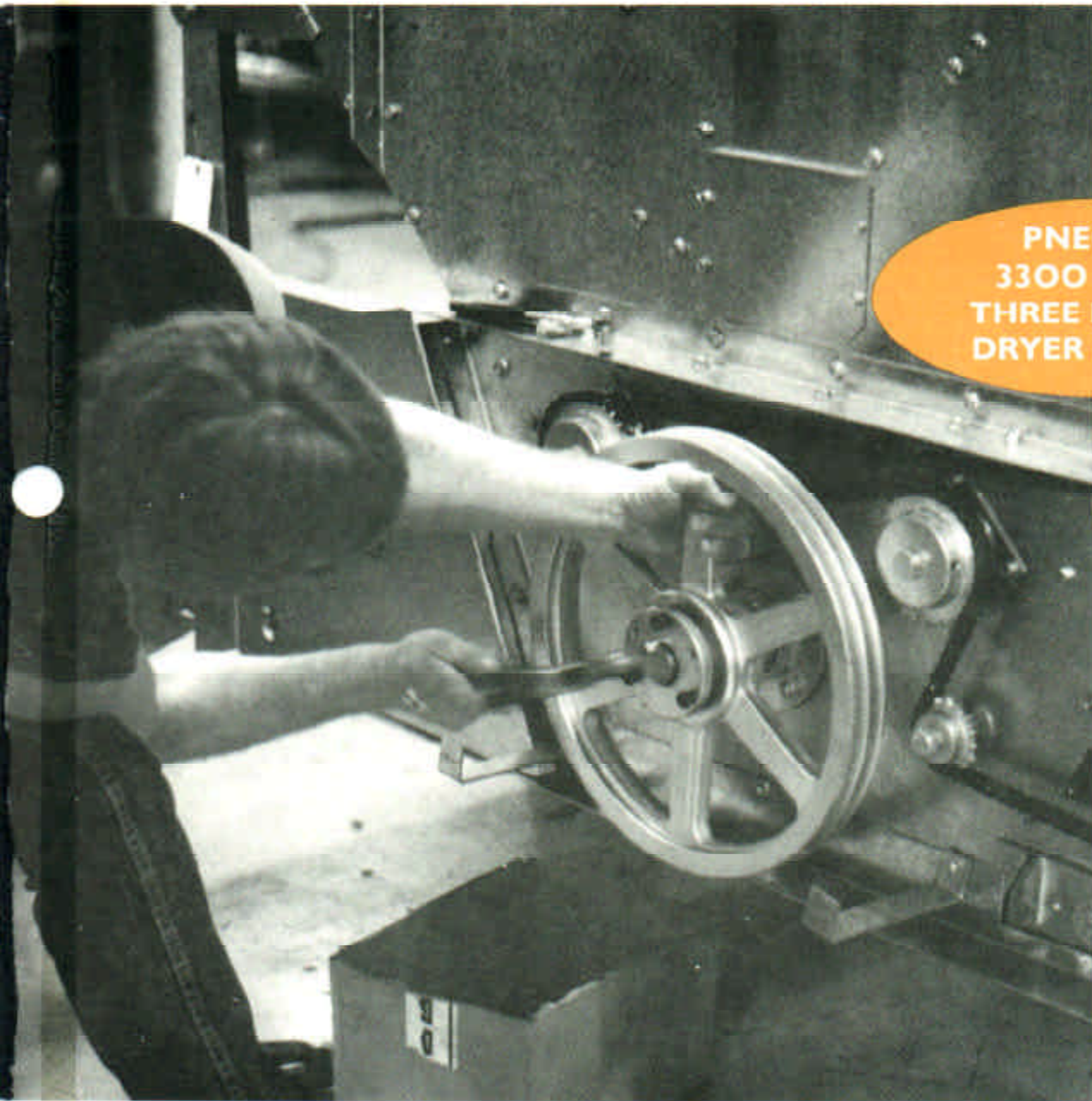

PNEG-357
3300 SERIES
THREE MODULE
DRYER MODELS

AIRSTREAM

A MEMBER OF
THE GSI GROUP



PARTS LIST

AIRSTREAM GRAIN DRYERS

CONTENTS: FOR 3312, 3314, 3318, 3320, 3322 AND 3326

BOTTOM MODULE.....	4
MIDDLE MODULE.....	8
TOP MODULE.....	12
MAIN FRAME.....	16
LOCATION OF CAPILARY SENSORS.....	18
TOP AUGER.....	20
BOTTOM AUGER CLEAN-OUT.....	23
BOTTOM AUGER AND METERING ROLLS.....	24
POWER AND CONTROL BOX.....	28
POWER BOX.....	30
POWER BOX, 1 PHASE BACK PANEL.....	32
POWER BOX, 3 PHASE BACK PANEL.....	34
CONTROL BOX.....	36
FAN HEATER CONTROL BOX.....	38
FAN HEATER.....	39
36" LP FAN HEATER PIPETRAIN.....	42
42" LP FAN HEATER PIPETRAIN.....	44
LP FUEL SUPPLY.....	46
36"& 42" NATURAL GAS FAN HEATER PIPETRAIN.....	48
NATURAL GAS FUEL SUPPLY.....	50

**GRAIN SYSTEMS,
INCORPORATED**
ASSUMPTION, IL 62510 217/226-4421

STACK DRYERS BOTTOM MODULE

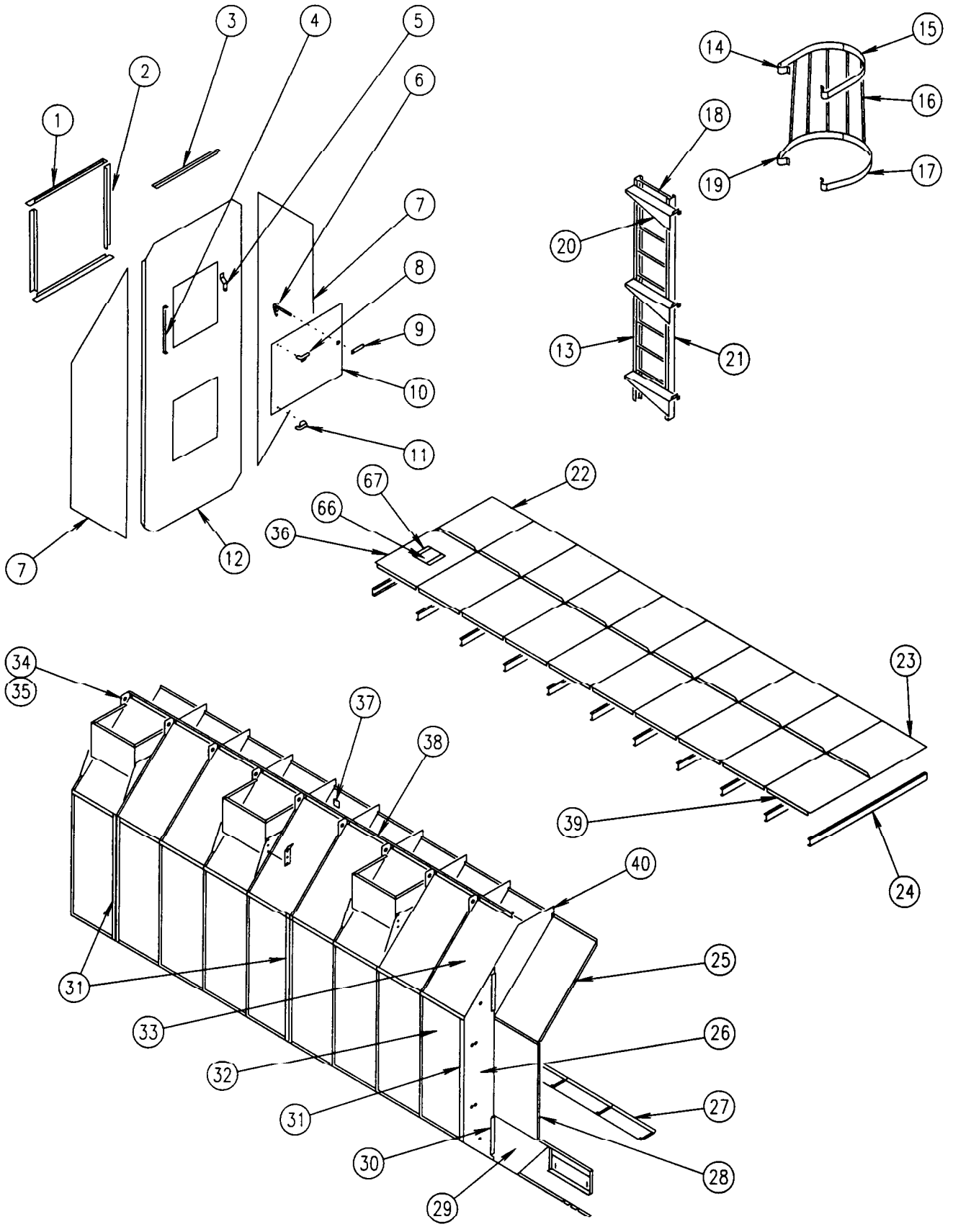

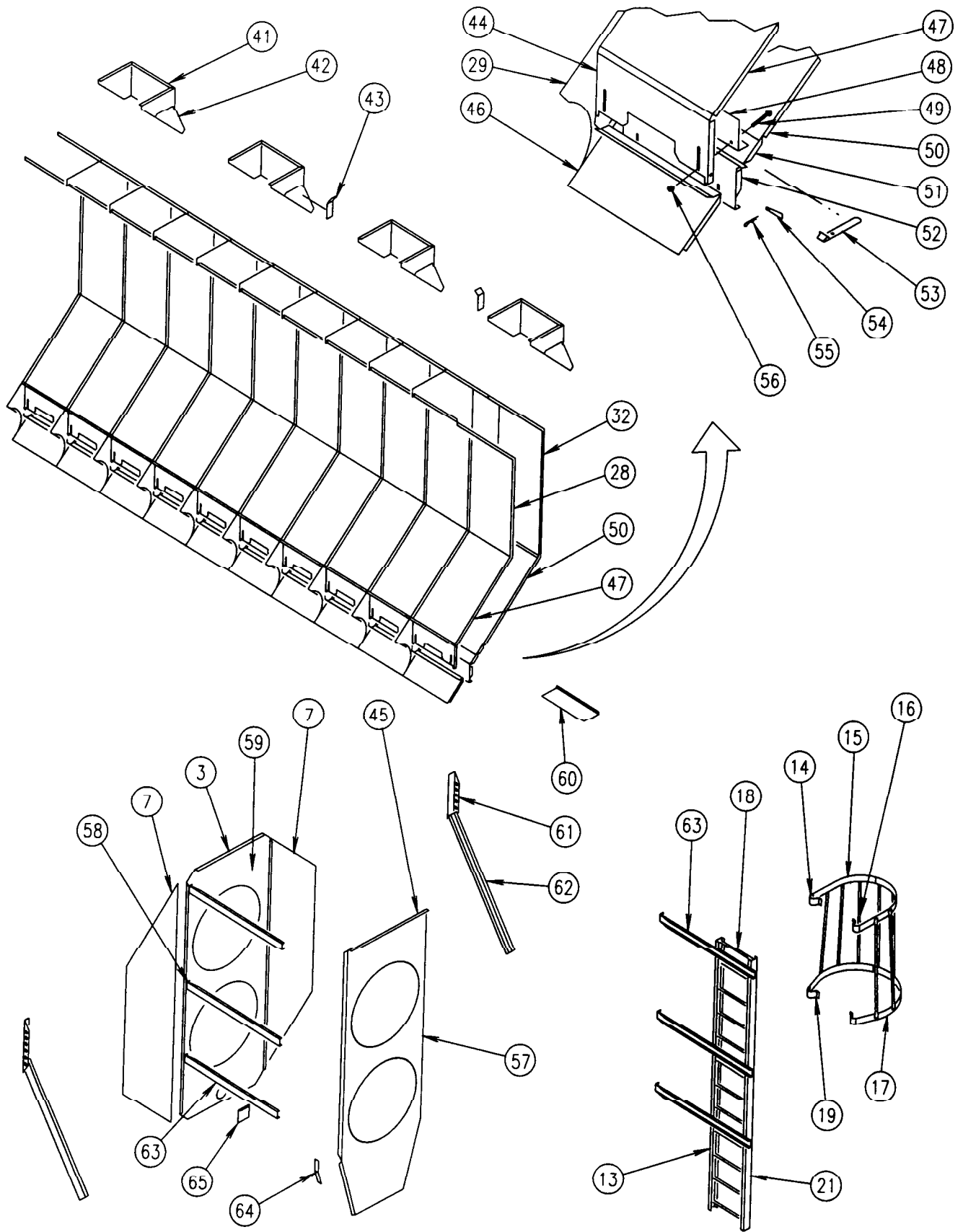

STACK DRYERS
BOTTOM MODULE

REF NO.	PART NO.	DESCRIPTION	QTY					
			3312	3314	3318	3320	3322	3326
1	D01-0396	REAR DOOR ANGLES, TOP AND BOTTOM	4	4	4	4	4	4
2	D01-0395	REAR DOOR ANGLES , SIDES	4	4	4	4	4	4
3	D01-0044	TOP ANGLE BRACKET	2	2	2	2	2	2
4	D31-0161	DOOR HINGE BRACKET	2	2	2	2	2	2
5	D01-0397	REAR DOOR LATCH, BRACKET	2	2	2	2	2	2
6	ACD-4513	DOOR HANDLE	2	2	2	2	2	2
7	D71-0020	COLUMN END PANEL	4	4	4	4	4	4
8	D31-0297	TOP HINGE	2	2	2	2	2	2
9	ACD-4514	INSIDE HANDLE	2	2	2	2	2	2
10	D01-0394	REAR ACCESS DOOR	2	2	2	2	2	2
11	D31-0296	BOTTOM HINGE	2	2	2	2	2	2
12	D51-0115	REAR END PANEL	1	1	1	1	1	1
13	D61-0093	R.H. LADDER SIDE RAIL	1	1	1	1	1	1
14	LS-4349	OSHA SAFETY CAGE LADDER BRACKET STD	4	4	4	4	4	4
15	LS-4351	OSHA SAFETY CAGE HOOP HALF	4	4	4	4	4	4
16	LS-4353	44" VERTICAL SUPPORT	12	12	12	12	12	12
17	LS-4352	OSHA SAFETY CAGE BELL HOOP HALF	4	4	4	4	4	4
18	D61-0096	LADDER RUNG	22	22	22	22	22	22
19	LS-4350	OSHA SAFETY CAGE LADDER BRACKET BELL	4	4	4	4	4	4
20	D61-0097	LADDER MOUNTING BRACKET	3	3	3	3	3	3
21	D61-0092	L.H. LADDER SIDE RAIL	1	1	1	1	1	1
22	D61-0027	L.H. REAR PLENUM DIVIDER - SHEET	1	1	1	1	1	1
23	D61-0025	L.H. PLENUM DIVIDER - SHEET	4	6	8	9	10	12
24	D61-0024	PLENUM SUPPORT CHANNEL	6	8	10	11	12	14
25	D01-0126	PLENUM TOP SHEET	12	14	18	20	22	26
26	D31-0055	COLUMN BULKHEAD	10	12	16	18	20	24
27	D01-0162	PLENUM BOTTOM CLOSURE PANEL, HINGED	6	7	9	10	11	13
28	D31-0012	PLENUM WALL	12	14	18	20	22	26
29	D01-0109	HOPPER BULKHEAD	10	12	16	18	20	24
30	D61-0038	BULKHEAD STIFFENER BAR	20	24	32	36	40	48
31	D61-0020	ATTACH BRACKET - WIND BUTTRESS	12	12	12	12	16	16
32	D31-0013	OUTSIDE WALL SHEET (STANDARD)	12	14	18	20	22	26
	D31-0040	OUTSIDE WALL SHEET (STAINLESS STEEL)						
33	D01-0127	ROOF SHEET (STANDARD)	12	14	18	20	22	26
	D01-0265	ROOF SHEET (STAINLESS STEEL)						
34	D01-0152	TOP EDGE ANGLE GUSSET, L.H.	12	14	18	20	22	26
35	D01-0153	TOP EDGE ANGLE GUSSET, R.H.	2	2	2	2	2	2
36	D61-0028	R.H. REAR PLENUM DIVIDER - SHEET	1	1	1	1	1	1
37	D31-0003	TOP EDGE ANGLE SPLICE	2	2	2	2	4	4
38	D31-0004	TOP EDGE ANGLE 95.875"		2	2		4	4
	D21-0003	TOP EDGE ANGLE 71.875"	4	2			2	
	D01-0168	TOP EDGE ANGLE 119.875"			2	4		2
39	D61-0026	R.H. PLENUM DIVIDER - SHEET	5	6	8	9	10	12
40	D01-0101	GARNER BULKHEAD	10	12	16	18	20	24
41	D61-0013	MODULE SUPPORT PAD	8	8	8	8	10	10
42	D61-0021	BODY TIE IN GUSSET L.H.	8	8	8	8	10	10
	D61-0022	BODY TIE IN GUSSET R.H.	8	8	8	8	10	10
43	D61-0012	CRANE BRACKET	4	4	4	4	4	4
44	D01-0430	METER ROLL UPPER SHIELD	12	14	18	20	22	26
45	D61-0023	TOP ANGLE FOR SUPPORT PANEL	1	1	1	1	1	1
46	D01-0048	TROUGH PANEL	12	14	18	20	22	26
47	D01-0428	PLENUM BOTTOM SHEET	12	14	18	20	22	26
48	D01-0431	METER ROLL STRIKEOFF PLATE	12	14	18	20	22	26

**STACK DRYERS
BOTTOM MODULE**

REF NO.	PART NO.	DESCRIPTION	QTY					
			3312	3314	3318	3320	3322	3326
49	S-6996	CARRIAGE BOLT 5/16" - 18 X 1 1/2"	24	28	36	40	44	52
50	D01-0128	HOPPER SHEET (STANDARD)	12	14	18	20	22	26
	D01-0267	HOPPER SHEET (STAINLESS STEEL)						
51	D01-0050	CONNECTOR SHEET	12	14	18	20	22	26
52	D01-0045	ACCESS DOOR	12	14	18	20	22	26
53	D01-0325	CONNECTOR CLEAN OUT TOOL	1	1	1	1	1	1
54	D01-0039	DOOR LATCH	24	28	36	40	44	52
55	S-6552	COTTER PIN #14	24	28	36	40	44	52
56	S-3611	HEX HEAD NUT 5/16" - 18	24	28	36	40	44	52
57	D51-0007	FAN HEATER FRONT SUPPORT	1					
	D51-0132	FAN HEATER FRONT SUPPORT		1	1	1	1	1
58	D01-0090	CONTROL PANEL MOUNTING BRACKET	3	3	3	3	3	3
59	D51-0004	FRONT END PANEL	1					
	D51-0131	FRONT END PANEL		1	1	1	1	1
60	D01-0117	SERVICE TOOL	2	2	2	2	2	2
61	D31-0129	DIAGONAL SUPPORT BRACKET	2	2	2	2	2	2
62	D01-0062	FRONT DIAGONAL SUPPORT	2	2	2	2	2	2
63	D51-0022	CONTROL PANEL SUPPORT	6	6	6	6	6	6
64	D51-0021	FAN SUPPORT STIFFNER	2	2	2	2	2	2
65	D01-0076	ACCESS DOOR	1	1	1	1	1	1
66	D31-0259	PLENUM DIVIDER CLEAN OUT DOOR	1	1	1	1	1	1
67	D31-0260	CLEAN OUT DOOR GUIDE	2	2	2	2	2	2

STACK DRYERS MIDDLE MODULE

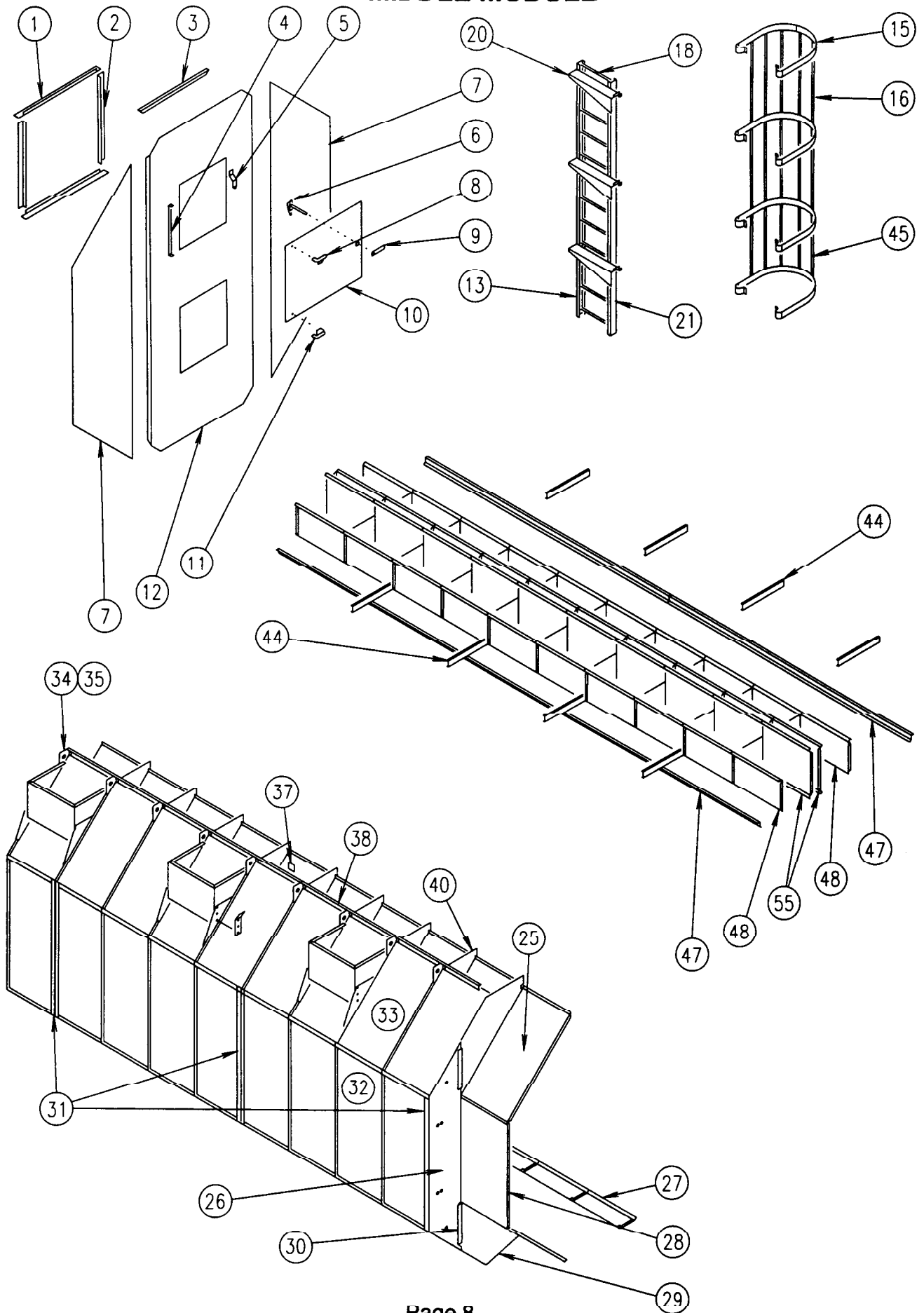

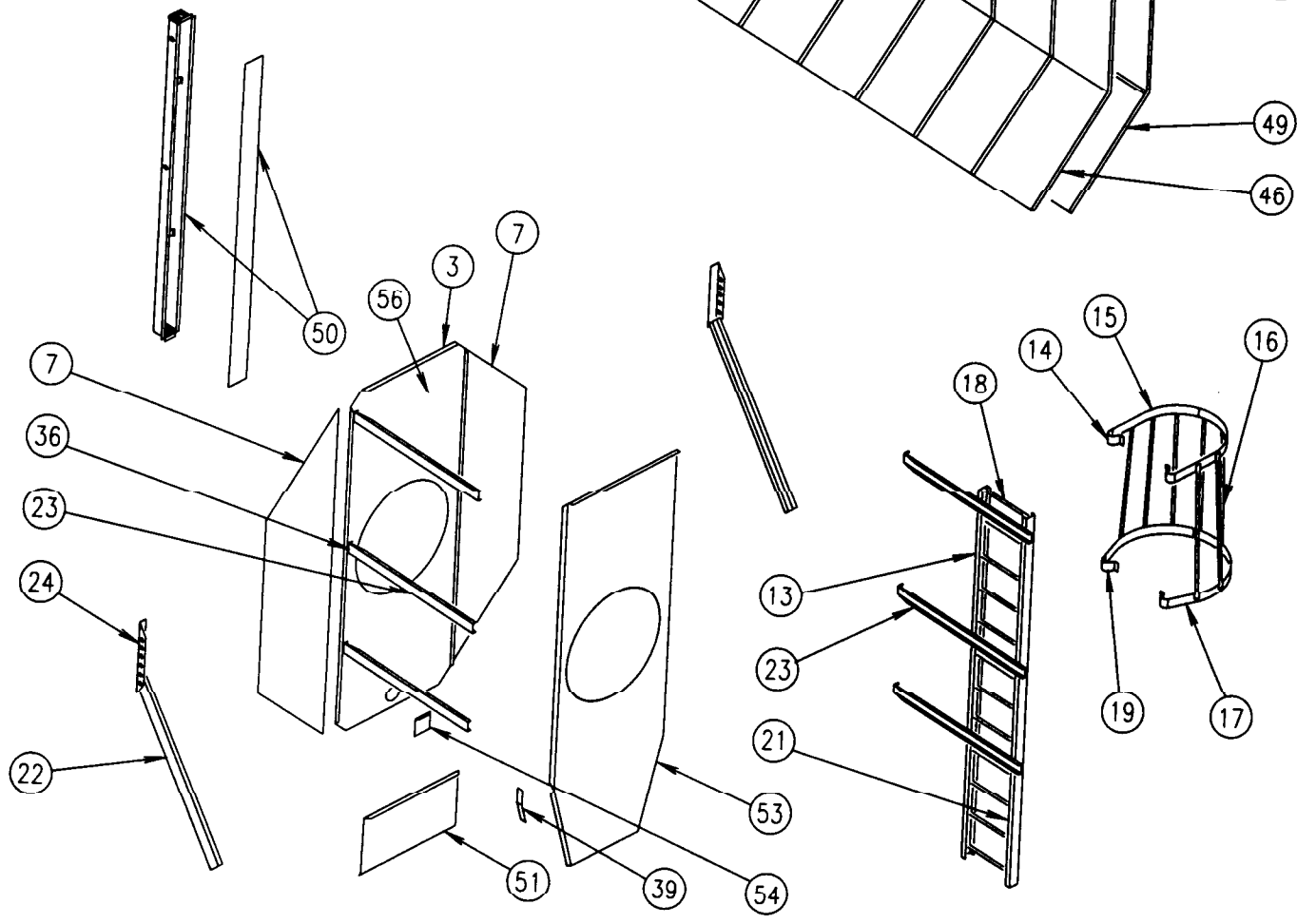
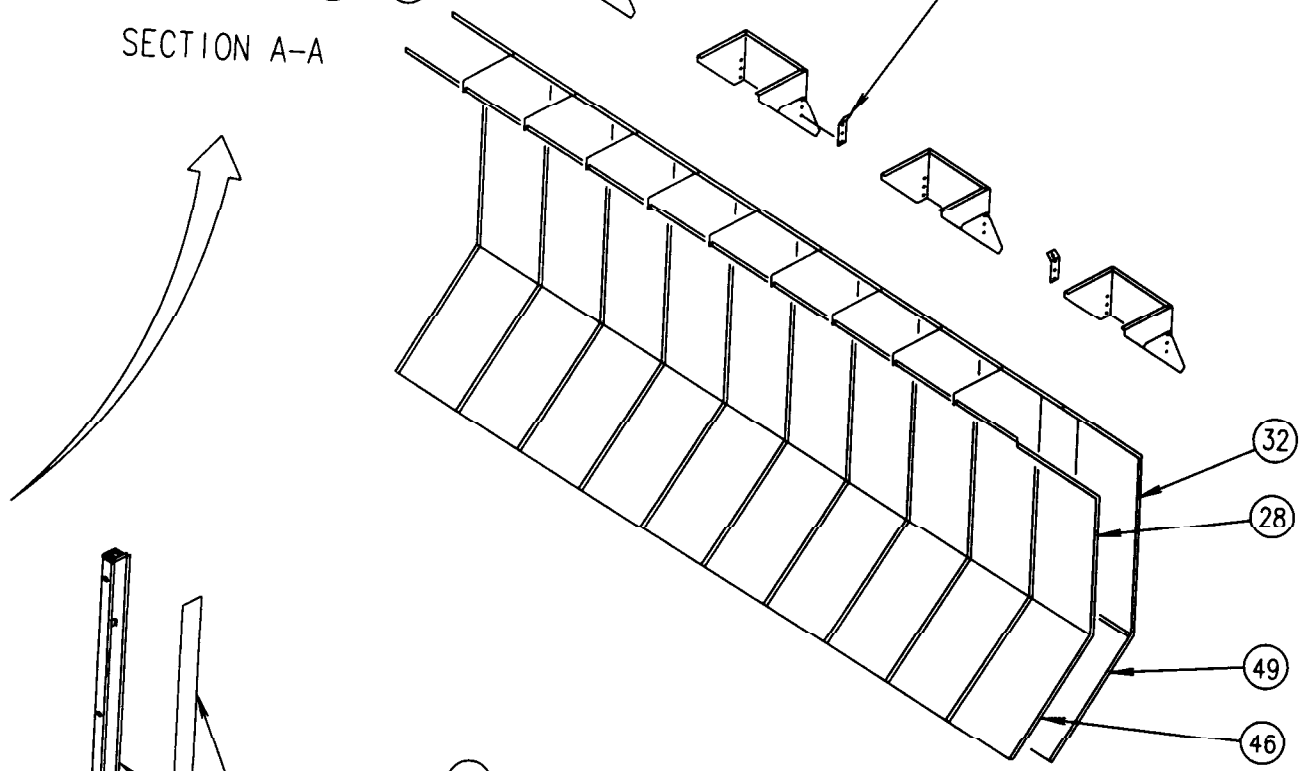
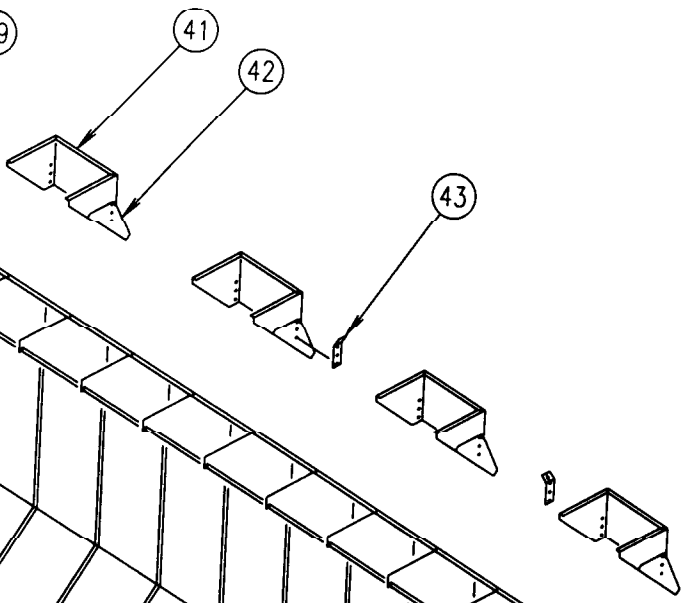
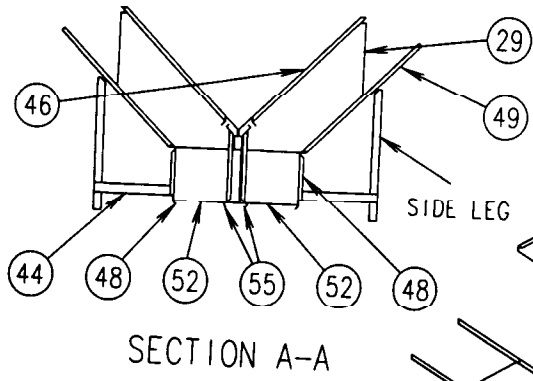

STACK DRYERS
MIDDLE MODULE

REF NO.	PART NO.	DESCRIPTION	QTY					
			3312	3314	3318	3320	3322	3326
1	D01-0396	REAR DOOR ANGLES, TOP AND BOTTOM	4	4	4	4	4	4
2	D01-0395	REAR DOOR ANGLES, SIDES	2	4	4	4	4	4
3	D01-0044	TOP ANGLE BRACKET	2	2	2	2	2	2
4	D31-0161	DOOR HINGE BRACKET	2	2	2	2	2	2
5	D01-0397	REAR DOOR LATCH, BRACKET	2	2	2	2	2	2
6	ACD-4513	DOOR HANDLE	2	2	2	2	2	2
7	D71-0020	COLUMN END PANEL	4	4	4	4	4	4
8	D31-0297	TOP HINGE	2	2	2	2	2	2
9	ACD-4514	INSIDE HANDLE	2	2	2	2	2	2
10	D01-0394	REAR ACCESS DOOR	2	2	2	2	2	2
11	D31-0296	BOTTOM HINGE	2	2	2	2	2	2
12	D51-0115	REAR END PANEL	1	1	1	1	1	1
13	D61-0093	R.H. LADDER SIDE RAIL	1	1	1	1	1	1
14	LS-4349	OSHA SAFETY CAGE LADDER BRACKET STD	4	4	4	4	4	4
15	LS-4351	OSHA SAFETY CAGE HOOP HALF	4	4	4	4	4	4
16	LS-4353	44" VERTICAL SUPPORT	12	12	12	12	12	12
17	LS-4352	OSHA SAFETY CAGE BELL HOOP HALF	4	4	4	4	4	4
18	D61-0096	LADDER RUNG	22	22	22	22	22	22
19	LS-4350	OSHA SAFETY CAGE LADDER BRACKET BELL	4	4	4	4	4	4
20	D61-0097	LADDER MOUNTING BRACKET	3	3	3	3	3	3
21	D61-0092	L.H. LADDER SIDE RAIL	1	1	1	1	1	1
22	D01-0062	FRONT DIAGONAL SUPPORT	2	2	2	2	2	2
23	D51-0022	CONTROL PANEL SUPPORT	6	6	6	6	6	6
24	D31-0129	DIAGONAL SUPPORT BRACKET	2	2	2	2	2	2
25	D01-0126	PLENUM TOP SHEET	12	14	18	20	22	26
26	D31-0055	COLUMN BULKHEAD	10	12	16	18	20	24
27	D01-0162	PLENUM BOTTOM CLOSURE PANEL, HINGED	6	7	9	10	11	13
28	D31-0012	PLENUM WALL	12	14	18	20	22	26
29	D01-0109	HOPPER BULKHEAD	10	12	16	18	20	24
30	D61-0038	BULKHEAD STIFFENER BAR	20	24	32	36	40	48
31	D61-0020	ATTACH BRACKET - WIND BUTTRESS	12	12	12	12	16	16
32	D31-0013	OUTSIDE WALL SHEET (STANDARD)	12	14	18	20	22	26
	D31-0040	OUTSIDE WALL SHEET (STAINLESS STEEL)						
33	D01-0127	ROOF SHEET (STANDARD)	12	14	18	20	22	26
	D01-0265	ROOF SHEET (STAINLESS STEEL)						
34	D01-0152	TOP EDGE ANGLE GUSSET, L.H.	12	14	18	20	22	26
35	D01-0153	TOP EDGE ANGLE GUSSET, R.H.	2	2	2	2	2	2
36	D01-0090	CONTROL PANEL MOUNTING BRACKET	3	3	3	3	3	3
37	D31-0003	TOP EDGE ANGLE SPLICE	2	2	2	2	4	4
38	D31-0004	TOP EDGE ANGLE 95.875"		2	2		4	4
	D21-0003	TOP EDGE ANGLE 71.875"	4	2			2	
	D01-0168	TOP EDGE ANGLE 119.875"			2	4		2
39	D51-0021	FAN SUPPORT STIFFNER	2	2	2	2	2	2
40	D01-0101	GARNER BULKHEAD	10	12	16	18	20	24
41	D61-0013	MODULE SUPPORT PAD	8	8	8	8	10	10
42	D61-0021	BODY TIE IN GUSSET L.H.	8	8	8	8	10	10
	D61-0022	BODY TIE IN GUSSET R.H.	8	8	8	8	10	10
43	D61-0012	CRANE BRACKET	4	4	4	4	4	4
44	D61-0019	MODULE TIE BRACE	8	8	8	8	12	12
45	D61-0110	34" VERTICAL SUPPORT	5	5	5	5	5	5
46	D01-0428	PLENUM BOTTOM SHEET	12	14	18	20	22	26
47	D61-0072	BOTTOM CONNECTING GUIDE (5 COLUMN)			2	4		4
	D71-0014	BOTTOM CONNECTING GUIDE (3 COLUMN)	4	2			2	2
	D01-0930	BOTTOM CONNECTING GUIDE (4 COLUMN)		2	2		4	
48	D61-0073	OUTER CONNECTING SHEET (STANDARD)	12	14	18	20	22	26
	D61-0076	OUTER CONNECTING SHEET (STAINLESS)						

**STACK DRYERS
MIDDLE MODULE**

REF NO.	PART NO.	DESCRIPTION	QTY					
			3312	3314	3318	3320	3322	3326
49	D01-0128	HOPPER SHEET (STANDARD)	12	14	18	20	22	26
	D01-0267	HOPPER SHEET (STAINLESS STEEL)						
50	D61-0145	WIRE WAY ASSEMBLY	1	1	1	1	1	1
51	D61-0077	END CONNECTING SECTION	1	1	1	1	1	1
52	D61-0103	BULKHEAD CONNECTING EXTENSION	10	12	16	18	20	24
53	D51-0007	FAN HEATER FRONT SUPPORT	1					
	D51-0132	FAN HEATER FRONT SUPPORT		1	1	1	1	1
54	D01-0076	ACCESS DOOR		1	1	1	1	1
55	D61-0017	INNER CONNECTING SHEET	12	14	18	20	22	26
56	D51-0004	FRONT END PANEL	1					
	D51-0131	FRONT END PANEL		1	1	1	1	1

STACK DRYERS TOP MODULE

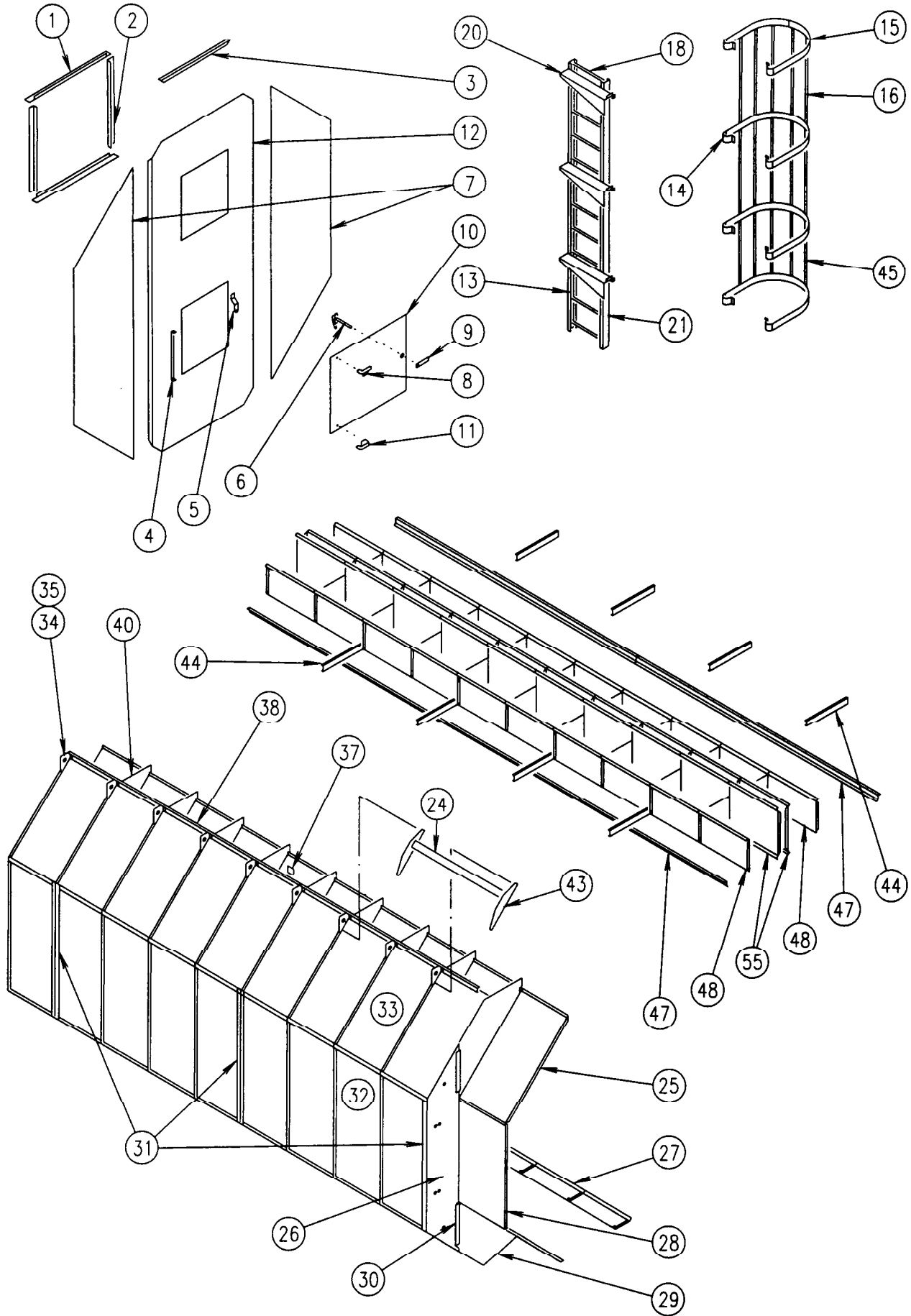

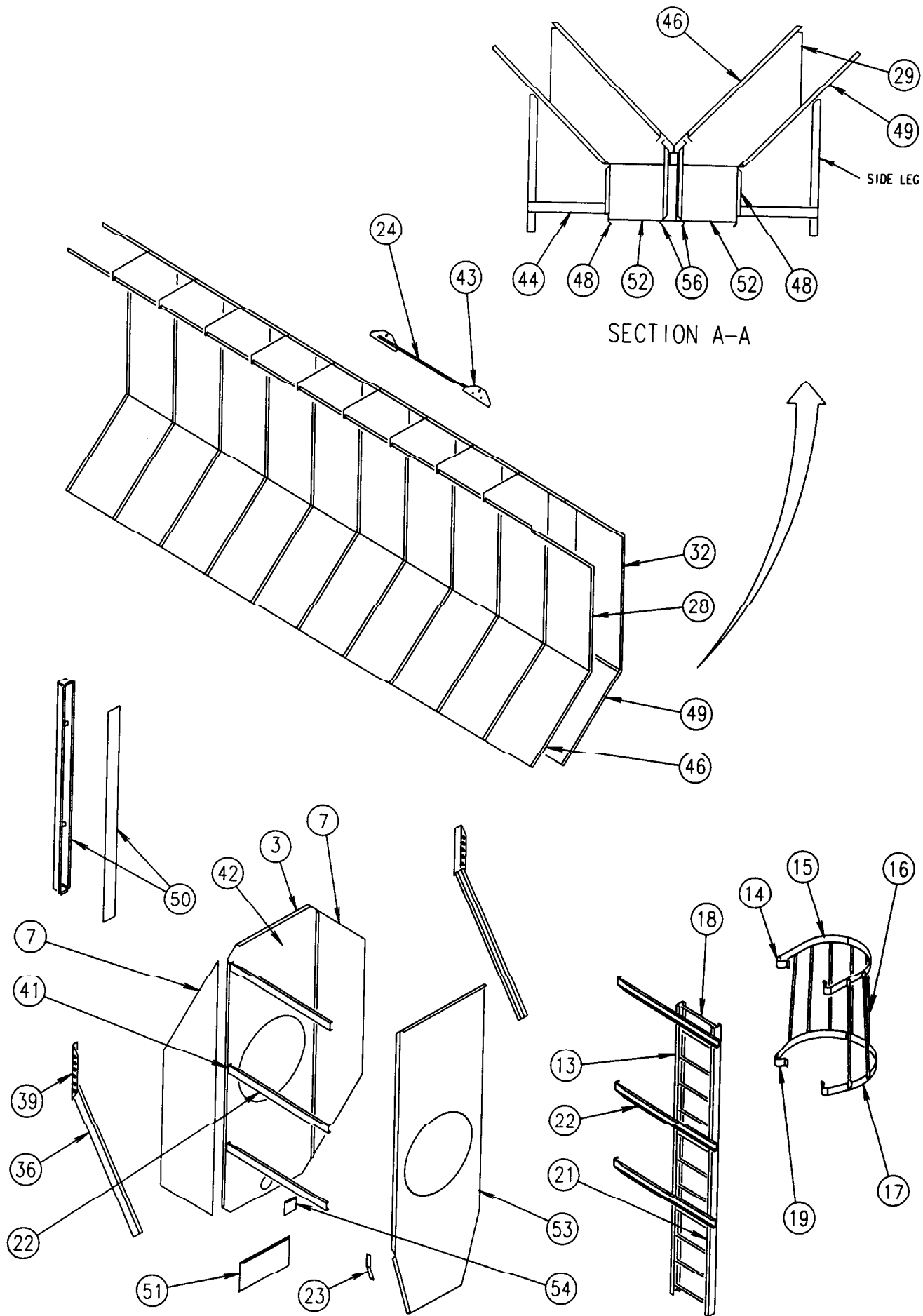

STACK DRYERS

TOP MODULE

REF NO.	PART NO.	DESCRIPTION	QTY					
			3312	3314	3318	3320	3322	3326
1	D01-0396	REAR DOOR ANGLES, TOP AND BOTTOM	2	2	2	2	2	2
2	D01-0395	REAR DOOR ANGLES, SIDES	2	2	2	2	2	2
3	D01-0044	TOP ANGLE BRACKET	2	2	2	2	2	2
4	D31-0161	DOOR HINGE BRACKET	2	2	2	2	2	2
5	D01-0397	REAR DOOR LATCH BRACKET	2	2	2	2	2	2
6	ACD-4513	DOOR HANDLE	2	2	2	2	2	2
7	D71-0020	COLUMN END PANEL	4	4	4	4	4	4
8	D31-0297	TOP HINGE	2	2	2	2	2	2
9	ACD-4514	INSIDE HANDLE	2	2	2	2	2	2
10	D01-0394	REAR ACCESS DOOR	2	2	2	2	2	2
11	D31-0296	BOTTOM HINGE	2	2	2	2	2	2
12	D51-0115	REAR END PANEL	1	1	1	1	1	1
13	D61-0095	R.H. LADDER SIDE RAIL	2	2	2	2	2	2
14	LS-4349	OSHA SAFETY CAGE LADDER BRACKET STD	10	10	10	10	10	10
15	LS-4351	OSHA SAFETY CAGE HOOP HALF	10	10	10	10	10	10
16	LS-4353	44" VERTICAL SUPPORT	17	17	17	17	17	17
17	LS-4352	OSHA SAFETY CAGE HALF BELL HOOP	2	2	2	2	2	2
18	D61-0096	LADDER RUNG	24	24	24	24	24	24
19	LS-4350	OSHA SAFETY CAGE LADDER BRACKET BELL	2	2	2	2	2	2
20	D61-0097	LADDER MOUNTING BRACKET	3	3	3	3	3	3
21	D61-0092	L.H. LADDER SIDE RAIL	2	2	2	2	2	2
22	D51-0022	CONTROL PANEL SUPPORT	6	6	6	6	6	6
23	D61-0021	FAN SUPPORT STIFFNER	2	2	2	2	2	2
24	D61-0014	HOISTING SPREADER BAR	2	2	2	2	2	2
25	D01-0126	PLENUM TOP SHEET	12	14	18	20	22	26
26	D31-0055	COLUMN BULKHEAD	10	12	16	18	20	24
27	D01-0429	PLENUM BOTTOM CLOSURE PANEL, HINGED	6	7	9	10	11	13
28	D31-0012	PLENUM WALL	12	14	18	20	22	26
29	D01-0109	HOPPER BULKHEAD	10	12	16	18	20	24
30	D61-0038	BULKHEAD STIFFENER BAR	20	24	32	36	40	48
31	D61-0020	ATTACH BRACKET - WIND BUTTRESS	12	12	12	12	16	16
32	D31-0013	OUTSIDE WALL SHEET (STANDARD)	12	14	18	20	22	26
	D31-0040	OUTSIDE WALL SHEET (STAINLESS STEEL)						
33	D01-0127	ROOF SHEET (STANDARD)	12	14	18	20	22	26
	D01-0265	ROOF SHEET (STAINLESS STEEL)						
34	D01-0152	TOP EDGE ANGLE GUSSET, L.H.	12	14	18	20	22	26
35	D01-0153	TOP EDGE ANGLE GUSSET, R.H.	2	2	2	2	2	2
36	D01-0062	FRONT DIAGONAL SUPPORT	2	2	2	2	2	2
37	D31-0003	TOP EDGE ANGLE SPLICE	2	2	2	2	4	4
38	D31-0004	TOP EDGE ANGLE 95.875		2	2		4	4
	D21-0003	TOP EDGE ANGLE 71.875	4	2			2	
	D01-0168	TOP EDGE ANGLE 119.875			2	4		2
39	D31-0129	DIAGONAL SUPPORT BRACKET	2	2	2	2	2	2
40	D01-0101	GARNER BULKHEAD	10	12	16	18	20	24
41	D01-0090	CONTROL PANEL MOUNTING BRACKET	3	3	3	3	3	3
42	D51-0004	FRONT END PANEL	1					
	D51-0131	FRONT END PANEL		1	1	1	1	1
43	D61-0015	TOP MODULE CRANE BRACKET	4	4	4	4	4	4
44	D61-0019	MODULE TIE BRACE	8	8	8	8	12	12
45	D61-0110	34" VERTICAL SUPPORT	5	5	5	5	5	5
46	D01-0428	PLENUM BOTTOM SHEET	12	14	18	20	22	26

STACK DRYERS

TOP MODULE

REF NO.	PART NO.	DESCRIPTION	QTY					
			3312	3314	3318	3320	3322	3326
47	D61-0072	BOTTOM CONNECTING GUIDE (5 COLUMN)			2	4		4
	D71-0014	BOTTOM CONNECTING GUIDE (3 COLUMN)	4	2			2	2
	D01-0930	BOTTOM CONNECTING GUIDE (4 COLUMN)		2	2		4	
48	D61-0073	OUTER CONNECTING SHEET (STANDARD)	12	14	18	20	22	26
49	D61-0076	OUTER CONNECTING SHEET (STAINLESS)						
	D01-0128	HOPPER SHEET (STANDARD)	12	14	18	20	22	26
50	D01-0267	HOPPER SHEET (STAINLESS STEEL)						
	D61-0145	WIRE WAY ASSEMBLY	1	1	1	1	1	1
	D61-0077	END CONNECTING SECTION	1	1	1	1	1	1
52	D61-0103	BULKHEAD CONNECTING EXTENSION	10	12	16	18	20	24
53	D51-0007	FAN HEATER FRONT SUPPORT	1					
	D51-0132	FAN HEATER FRONT SUPPORT		1	1	1	1	1
54	D01-0076	ACCESS DOOR	1	1	1	1	1	1
55	D61-0017	INNER CONNECTING SHEET	12	14	18	20	22	26

STACK DRYERS MAIN FRAME

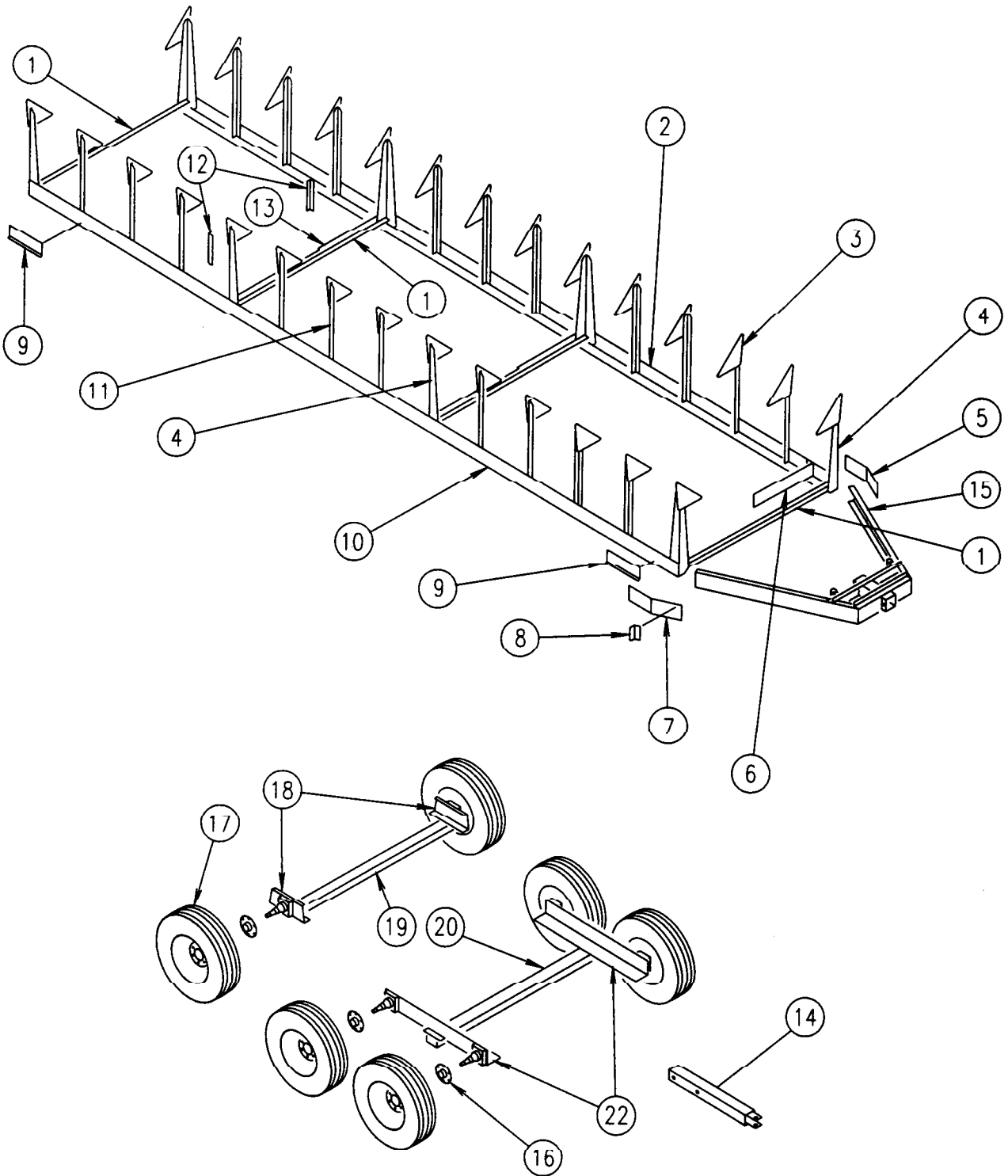

(21) TRANSPORT ASSEMBLY

STACK DRYERS

MAIN FRAME

REF NO.	PART NO.	DESCRIPTION	QTY					
			3312	3314	3318	3320	3322	3326
1	D01-0008	FRONT & REAR FRAME TIE	3	3	3	3	4	4
2	D51-0001	SIDE RAIL ANGLE, L.H.	1					
	D21-0010	SIDE RAIL ANGLE, L.H.		1				
	D31-0043	SIDE RAIL ANGLE, L.H.			1			
	D61-0001	SIDE RAIL ANGLE, L.H.				1		
	D101-0001	SIDE RAIL ANGLE, L.H.					1	
	D71-0002	SIDE RAIL ANGLE, L.H.						1
3	D01-0004	GUSSET PLATE	14	16	20	22	24	28
4	D01-0007	CORNER LEG	6	6	6	6	8	8
5	D01-0011	HITCH BRACKET, L.H.	1	1	1	1	1	1
6	D01-0016	MOTOR MOUNT BRACKET	2	2	2	2	2	2
7	D01-0012	HITCH BRACKET, R.H.	1	1	1	1	1	1
8	D61-0054	ATTACH BRACKET FOR SERVICE PLATFORM	2	2	2	2	2	2
9	D61-0011	FRAME TIE DOWN	4	4	4	4	4	4
10	D51-0002	SIDE RAIL ANGLE, R.H.	1					
	D21-0011	SIDE RAIL ANGLE, R.H.		1				
	D31-0044	SIDE RAIL ANGLE, R.H.			1			
	D61-0002	SIDE RAIL ANGLE, R.H.				1		
	D101-0002	SIDE RAIL ANGLE, R.H.					1	
	D71-0001	SIDE RAIL ANGLE, R.H.						1
11	D01-0005	SIDE LEG	8	10	14	16	16	20
12	D01-0015	STIFFENER ANGLE	2	2	2	2	2	2
13	D31-0118	SECONDARY CROSS TIE ANGLE	1	1	1	1	2	2
14	D01-0022	HITCH INNER TUBE WELDMENT	1	1	1	1	1	1
15	D01-0029	TRANSPORT HITCH	1	1	1	1	1	1
16	D01-0188	HUB	4	4	6	6	6	8
17	D01-0189	TIRE & RIM ASSEMBLY	4	4	6	6	6	8
18	D01-0032	AXLE BRACKET WELDMENT	4		2	2	2	
19	D01-0023	AXLE CROSS CHANNEL	2		1	1	1	
20	D31-0061	TRANSPORT CROSS TUBE		1	1	1	1	2
21	TK-02	TRANSPORT KIT : 15, 17, 18, 19, 20	1					
	TK-02-S	TRANSPORT KIT : 15, 16, 17, 18, 21		1				
	TK-03	TRANSPORT KIT : 15, 16, 17, 18, 19, 20, 21		1	1	1		
22	TK-04	TRANSPORT KIT : 15, 16, 17, 18, 21						1
	D31-0060	TRANSPORT WELDMENT	2	2	2	2	2	4

STACK DRYERS

LOCATION OF CAPILARY SENSORS

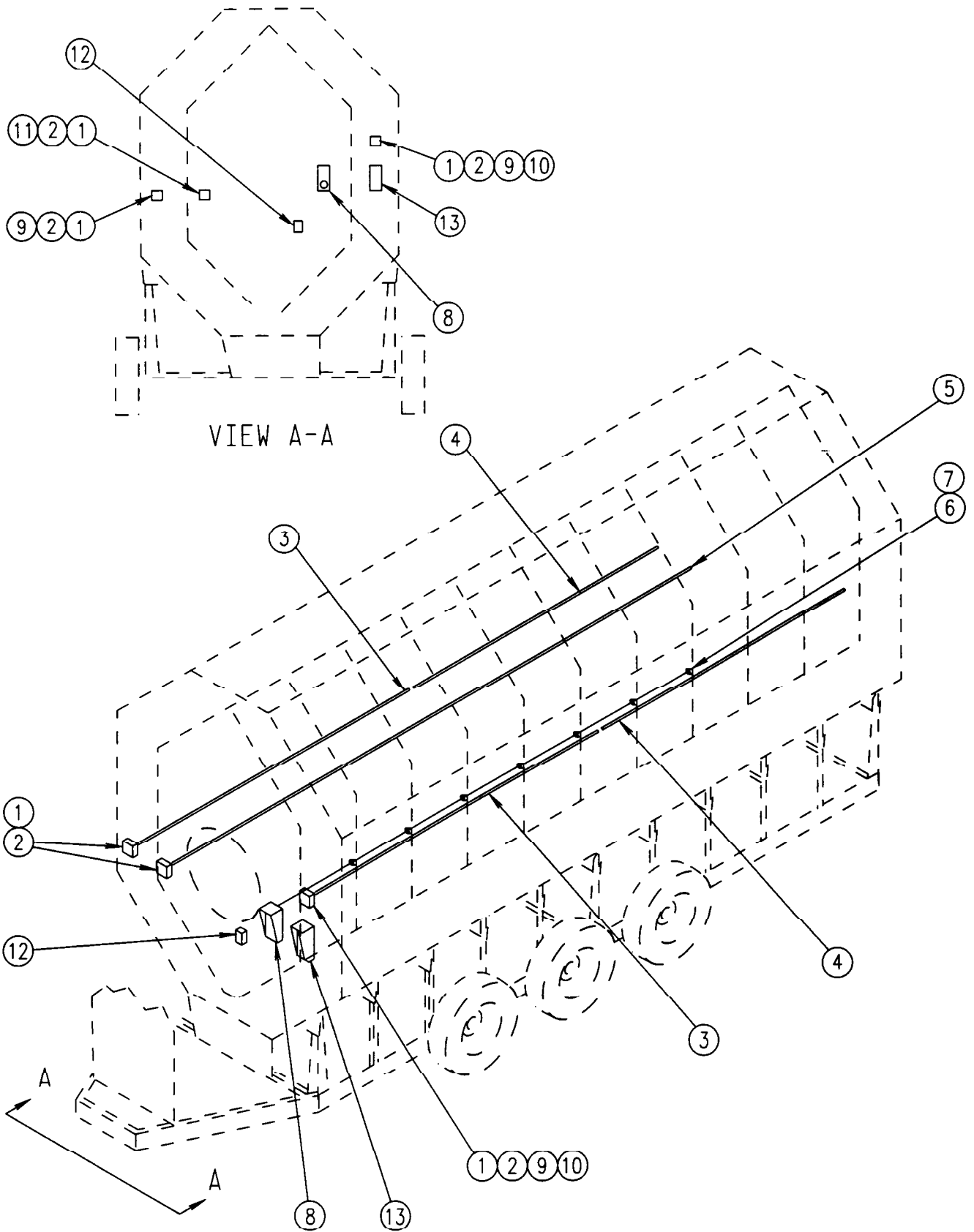

STACK DRYERS

LOCATION OF CAPILARY SENSORS

REF. NO.	PART NO.	DESCRIPTION	QTY					
			3312	3314	3318	3320	3322	3326
1	FH-6972	4" X 4" HANDY BOX	9	9	9	9	9	9
2	D01-0254	HI-LIMIT MOUNTING BRACKET	9	9	9	9	9	9
3	D31-0041	CONDUIT, COLUMN HI-LIMIT, 120" LONG	6	6	6	6	6	8
4	D21-0009	CONDUIT, COLUMN HI-LIMIT, 32" LONG	6	6				
	D31-0042	CONDUIT, COLUMN HI-LIMIT, 80" LONG			6			
	D01-0271	CONDUIT, COLUMN HI-LIMIT, 104" LONG				6	6	
	D51-0024	CONDUIT, COLUMN HI-LIMIT, 24" LONG					6	
	D71-0019	CONDUIT, COLUMN HI-LIMIT, 56" LONG						6
5	D21-0018	1/2" SCH 40 PIPE THREADED, 162"	6	6				
	D31-0150	1/2" SCH 40 PIPE THREADED, 210"			6			
	D61-0138	1/2" SCH 40 PIPE THREADED, 234"				6		
	D101-0010	1/2" SCH 40 PIPE THREADED, 240"					6	
	D71-0018	1/2" SCH 40 PIPE THREADED, 252"						6
	D71-0015	1/2" SCH 40 PIPE THREADED, 54"						6
6	D02-0023	INSULATED CAPILLARY HOLDER	18	18	21	21	21	21
7	D01-0123	BRACKET	18	18	21	21	21	21
8	D01-0184	THERMOSTAT SENSOR HOUSING ASSY.	6	6	6	6	6	6
	D03-0047	TEMPERATURE CONTROL 110-290 DEG	3	3	3	3	3	3
	D03-0062	THERMOMETER	3	3	3	3	3	3
	D01-0275	THERMOSTAT SENSOR HOUSING SUB ASSY.	6	6	6	6	6	6
9	D03-0045	RTD TEMPERATURE SENSOR	6	6	6	6	6	6
10	D03-0005	FIXED GRAIN HI-LIMIT THERMOSTAT	6	6	6	6	6	6
11	D03-0004	PLENUM HI-LIMIT THERMOSTAT	3	3	3	3	3	3
12	D01-0672	AIR SWITCH BOX ASSEMBLY	3	3	3	3	3	3
	D03-0167	AIR SWITCH	3	3	3	3	3	3
13	D03-0083	TEMPERATURE CONTROL	3	3	3	3	3	3

STACK DRYERS TOP AUGER

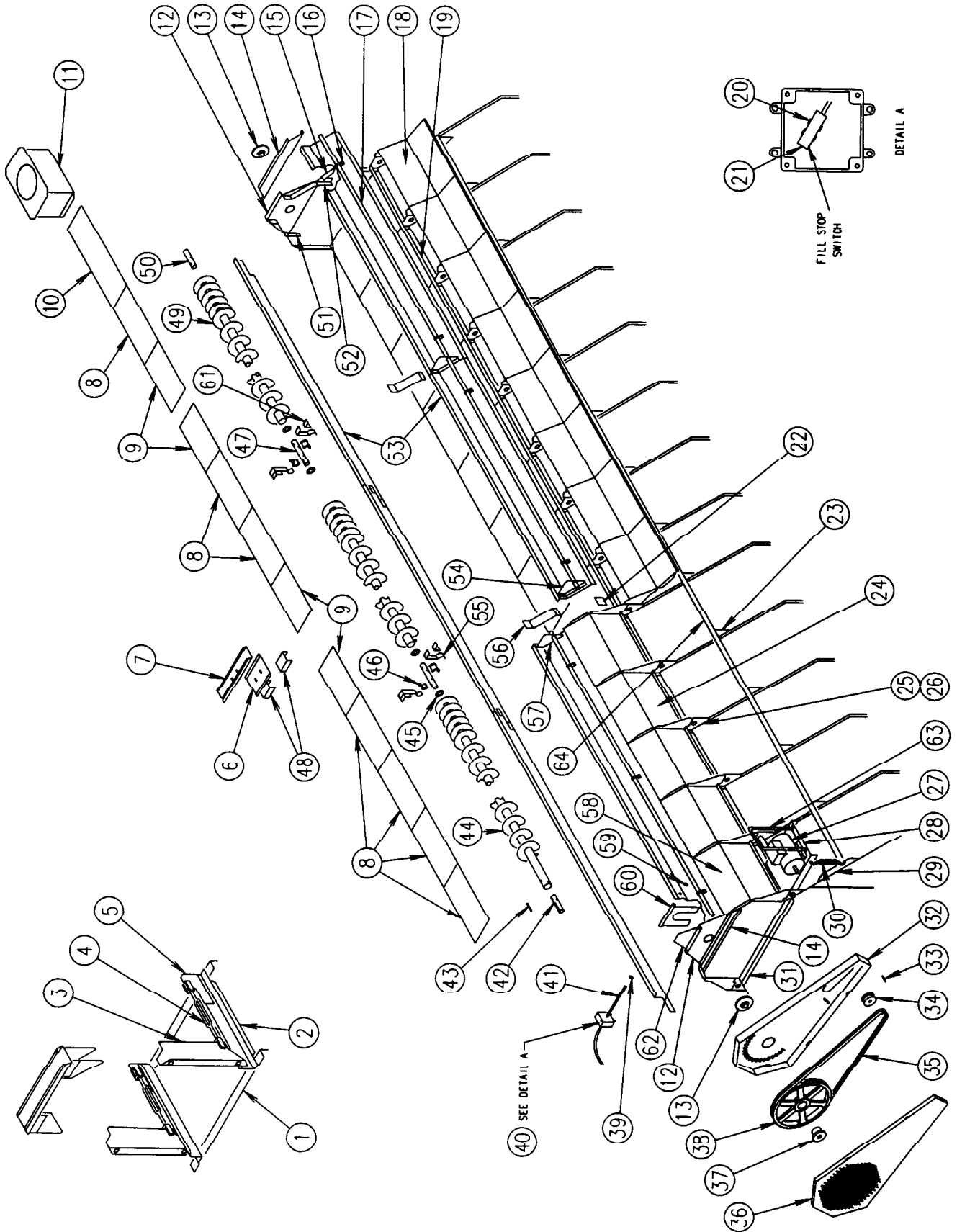

STACK DRYERS

TOP AUGER

REF NO.	PART NO.	DESCRIPTION	QTY					
			3312	3314	3318	3320	3322	3326
1	D31-0007	WET BIN MOUNTING ANGLE	2	2	2	2	4	4
2	D01-0443	WET BIN LIFT MOUNTING BASE	2	2	2	2	4	4
3	D31-0019	TOP AUGER CENTER SUPPORT	2	2	2	2	4	4
4	D32-0003	TURN BUCKLE	2	2	2	2	4	4
5	D31-0016	TURN BUCKLE EAR	2	2	2	2	4	4
6	D31-0015	TOP AUGER CENTER BEARING SUPPORT	2	2	2	2	4	4
7	D31-0011	CENTER STABILIZER BEAM	1	1	1	1	2	2
8	D01-0384	TOP AUGER COVER, 24.250"	2	3	5	6	5	7
9	D31-0309	TOP AUGER COVER, 20.250"					4	4
10	D01-0385	TOP AUGER COVER, 30.25"	1	1	1	1	1	1
11	D01-0193	FILL HOPPER ASSEMBLY	1	1	1	1	1	1
12	D31-0028	TOP AUGER HOUSING END	2	2	2	2	2	2
13	D32-0001	1 1/2" FLANGELETTE BEARING	2	2	2	2	2	2
14	D01-0156	AUGER HOUSING END TIE CHANNEL	2	2	2	2	2	2
15	D01-0432	WET BIN END	2	2	2	2	2	2
16	D01-0140	HAND RAIL HANGER BRACKET	8	8	8	8	12	14
17	D21-0001	HAND RAIL, 71.75"	4	2			2	
	D31-0006	HAND RAIL, 95.75"		2	2		2	
	D01-0151	HAND RAIL, 119.75"			2	4		4
18	D01-0438	WET BIN RIGHT SIDE END SECTION	2	2	2	2	2	2
19	D31-0004	TOP EDGE ANGLE, 95.875 "		2	2	2	4	4
	D21-0003	TOP EDGE ANGLE, 71.875"	4	2			4	
	D01-0168	TOP EDGE ANGLE, 119.875"			2	2		4
20	SPD-2098	MERCURY SWITCH CLIP	2	2	2	2	2	2
21	D03-0010	MERCURY SWITCH	2	2	2	2	2	2
22	D31-0003	TOP EDGE ANGLE SPLICE	2	2	2	2	4	4
23	D01-0113	LADDER BRACKET	26	28	32	34	36	40
24	D01-0436	WET BIN SIDE SECTION	8	10	14	16	18	22
25	D01-0153	TOP EDGE ANGLE GUSSET R.H.	2	2	2	2	2	2
26	D01-0152	TOP EDGE ANGLE GUSSET L.H.	12	14	18	20	22	26
27	300-1	3 HP MOTOR 1-PH	1					
	300-3	3 HP MOTOR 3-PH	1					
	500-1	5 HP MOTOR 1-PH		1				
	500-3	5 HP MOTOR 3-PH		1	1			
	712-3	7.5 HP MOTOR 3-PH 230V 1750 RPM				1	1	
	1000-3	10 HP MOTOR 3-PH 230V 1750 RPM						1
28	D01-0173	TOP MOTOR MOUNT	1	1	1	1	1	1
29	D01-0170	MOTOR MOUNT ANCHOR BRACKET	1	1	1	1	1	1
30	D01-0465	TOP MOTOR BELT TIGHTENER	1	1	1	1	1	1
31	D01-0044	TOP ANGLE BRACKET	4	4	4	4	4	4
32	D01-0453	TOP AUGER BELT GUARD BODY	1	1	1	1	1	1
33	D01-0098	KEY 1/4" X 1/4" X 1"	1	1	1	1	1	1
34	D03-0174	MOTOR SHEAVE	1					
	D32-0024	MOTOR SHEAVE		1	1			
	D62-0003	MOTOR SHEAVE				1	1	1
35	D01-0464	DRIVE BELT SET	2	2	2	2	2	2
36	D01-0452	TOP AUGER BELT GUARD COVER	1	1	1	1	1	1
37	D32-0019	TOP AUGER SHEAVE BUSHING 1 1/2"	1	1	1	1	1	1
38	D52-0001	TOP AUGER SHEAVE	1	1	1	1	1	1
39	D02-0026	MERCURY SWITCH SHAFT BUSHING	2	2	2	2	2	2
40	D01-0192	MERCURY SWITCH ASSEMBLY	1	1	1	1	1	1
41	D01-0103	MERCURY SWITCH SHAFT	1	1	1	1	1	1
42	D31-0090	AUGER STUB SHAFT	1	1	1	1	1	1
43	D31-0137	3/8" X 3/8" X 2 1/2" LONG KEY	1	1	1	1	1	1
44	D21-0015	FRONT AUGER	1	1			1	
	D31-0092	FRONT AUGER			1	1		1

STACK DRYERS
TOP AUGER

REF NO.	PART NO.	DESCRIPTION	QTY					
			3312	3314	3318	3320	3322	3326
45	D31-0048	MACHINE WASHER 1 1/2" X 2 1/4"	2	2	2	2	4	4
46	D31-0026	1 1/2" AUGER HANGER BEARING	1	1	1	1	2	2
47	D31-0076	AUGER SPLICE SHAFT	1	1	1	1	2	2
48	D31-0009	GUSSET ATTACHMENT BRACKET	2	2	2	2	4	4
49	D01-0801	REAR AUGER	1					
	D31-0267	REAR AUGER		1	1		2	2
	D31-0092	REAR AUGER				1		
50	D31-0005	TOP AUGER STUB SHAFT		1	1	1	1	1
51	D01-0147	TOP AUGER HOUSING HINGE L.H.	2	2	2	2	2	2
52	D01-0148	TOP AUGER HOUSING HINGE R.H.	2	2	2	2	2	2
53	D21-0002	TOP AUGER TROUGH SIDE, 71.875"	4			2		
	D31-0010	TOP AUGER TROUGH SIDE, 95.875"		4		2	2	
	D01-0161	TOP AUGER TROUGH SIDE, 119.875"			4		4	
54	D31-0002	HAND RAIL CENTER GUSSET R.H.	2	2	2	2	4	4
55	D31-0024	TOP AUGER BEARING HANGER	2	2	2	2	4	4
56	D31-0008	TOP AUGER TROUGH SPLICE	2	2	2	2	4	4
57	D31-0001	HAND RAIL CENTER GUSSET L.H.	2	2	2	2	4	4
58	D01-0437	WET BIN LEFT SIDE END SECTION	2	2	2	2	2	2
59	D02-0026	MERCURY SWITCH SHAFT BUSHING	2	2	2	2	2	2
60	D01-0167	MERCURY SWITCH PADDLE	1	1	1	1	1	1
61	D31-0022	HANGER BEARING BRACE	2	2	2	2	4	4
62	D01-0155	BELT GUARD MOUNTING BRACKET	1	1	1	1	1	1
63	D01-0424	TOP HAND HOLD	1	1	1	1	1	1
64	D31-0014	WET BIN TRANSPORT ANGLE 96"		2	2		4	4
	D21-0003	WET BIN TRANSPORT ANGLE 72"	4	2			2	
	D01-0168	WET BIN TRANSPORT ANGLE 120"			2	4		2

STACK DRYERS

BOTTOM AUGER CLEAN-OUT

REF NO.	PART NO.	DESCRIPTION	QTY					
			3312	3314	3318	3320	3322	3326
1	D01-0048	TROUGH PANEL WELDMNT	12	14	18	20	22	26
2	D31-0023	CLEAN-OUT EXTENSION, 90.75"		2	2		4	4
	D01-0181	CLEAN-OUT EXTENSION, 114.75"			2	4		2
3	D21-0006	CLEAN-OUT EXTENSION, 66.75"	4	2			2	
	D01-0177	CLEAN-OUT SUPPORT STRAP	6	7	10	11	12	14
4	D01-0175	CLEAN-OUT HINGE BRACKET	4	4	5	6	6	7
5	D01-0308	CLEAN-OUT HINGE	4	4	5	6	6	7
6	D31-0130	CLEAN-OUT DOOR SUPPORT CHANNEL 8"		1	1		2	2
	D01-0307	CLEAN-OUT DOOR SUPPORT CHANNEL 10"			1	2		1
7	D21-0012	CLEAN-OUT DOOR SUPPORT CHANNEL 6"	1	1			1	
	D31-0021	CLEAN-OUT DOOR, 91"		1	1		2	2
	D01-0180	CLEAN-OUT DOOR, 115"			1	2		1
8	D21-0005	CLEAN-OUT DOOR, 67"	2	1			1	
	D01-0185	CLEAN-OUT END SEAL WELDMNT	4	4	4	4	6	6
9	D01-0261	LONG LINKAGE BAR, 37.25"	2	2	2	2	2	2
10	D01-0293	LONG LINKAGE BAR, 30.188"	2	2	2	2	4	4
11	D01-0296	SHORT LINKAGE BAR WELDMNT	4	4	4	4	6	6
12	D01-0294	CLEAN-OUT DOOR HANDLE	4	4	4	4	6	6
13	D01-0299	PIVOT ROD BRACKET	3	3	3	3	6	6
14	D01-0264	PIVOT ROD, 25.188"	2	2	2	2	2	2
15	D31-0162	PIVOT ROD, 49.625"	1	1	1	1	2	2

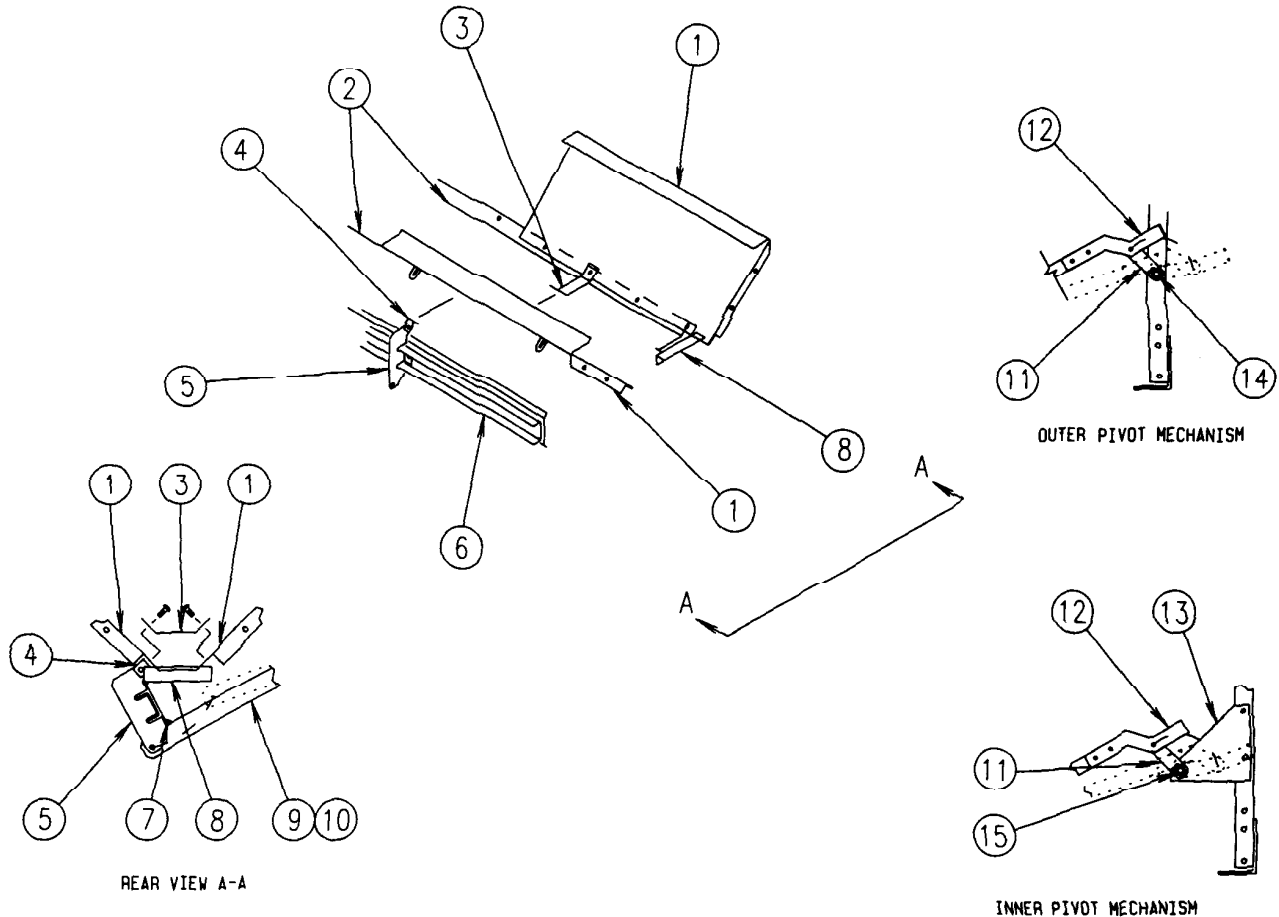

STACK DRYERS

BOTTOM AUGER AND METERING ROLLS

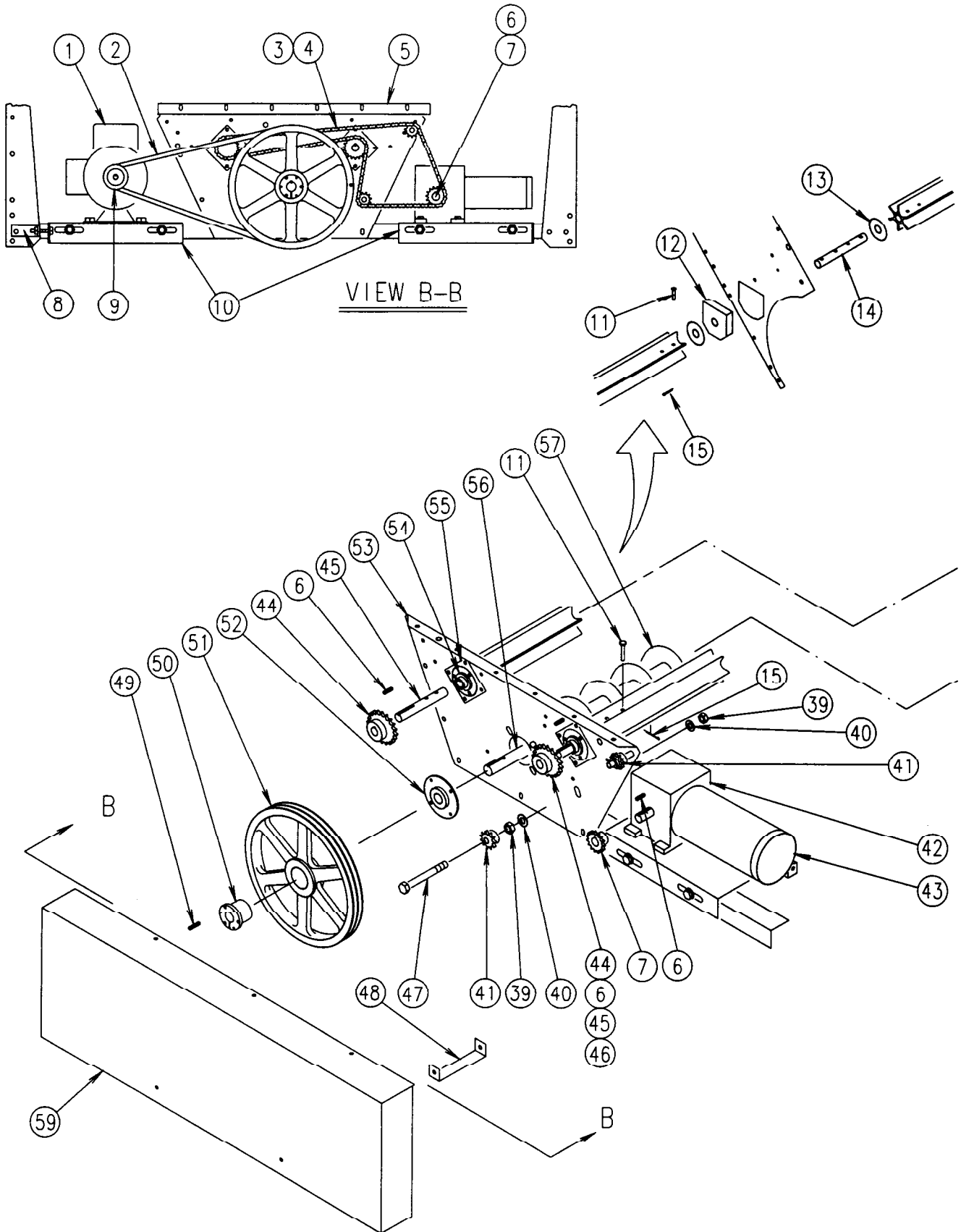

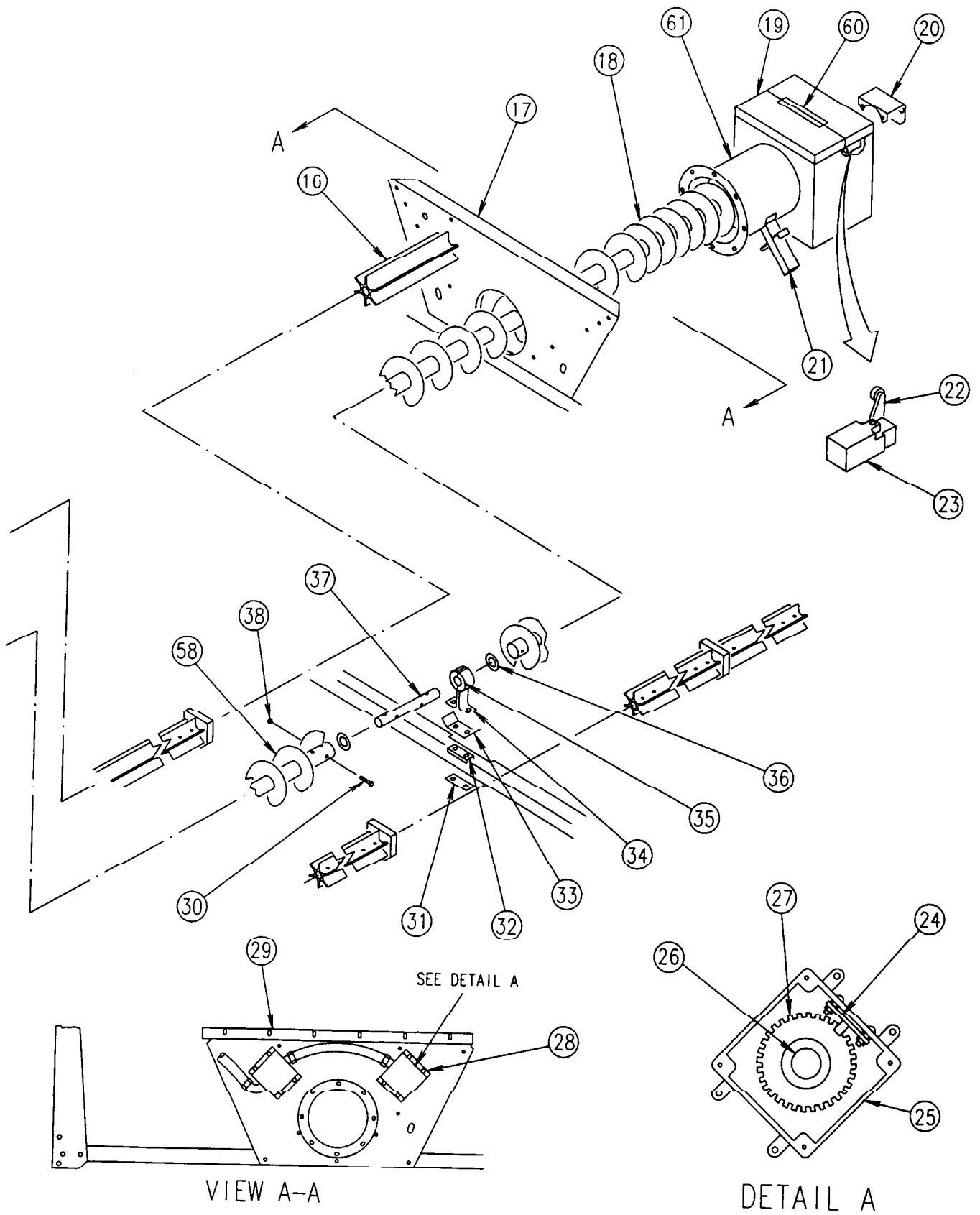

STACK DRYERS
BOTTOM AUGER AND METERING ROLLS

REF NO.	PART NO.	DESCRIPTION	QTY						
			3312	3314	3318	3320	3322	3326	
1	300-1	MOTOR 3 HP 1-PH	1						
	300-3	MOTOR 3 HP 3-PH	1						
	500-1	MOTOR 5 HP 1-PH		1					
	500-3	MOTOR 5 HP 3-PH		1	1				
	712-3	MOTOR 7.5 HP 3-PH				1	1		
	1000-3	MOTOR 10 HP 3-PH							1
2	D32-0023	BELT BX80	2	2	2	2	2		
	D02-0080	BELT BX75 (3 PH UNITS)	2	2	2	2	2		2
3	D02-0031	CHAIN LINK NO. 40	1	1	1	1	1		1
4	D01-0404	85" CHAIN NO. 40	1	1	1	1	1		1
5	D01-0461	BOTTOM ANGLE BRACKET FRONT	1	1	1	1	1		1
6	D01-0098	KEY 1/4" X 1/4" X 1"	3	3	3	3	3		3
7	D02-0004	SPROCKET H4015-1	1	1	1	1	1		1
8	D01-0017	MOTOR ADJUSTMENT BRACKET	1	1	1	1	1		1
9	D32-0024	SHEAVE 2BK32 (1 1/8" BORE)		1	1				
	D62-0003	SHEAVE 2BK40 (1 3/8" BORE)				1	1		1
10	D01-0081	GEAR BOX MOUNTING BRACKET	2	2	2	2	2		2
11	D02-0028	CLEVIS PIN 5/16" X 1 3/4"	24	32	40	40	48		56
12	D02-0061	METER ROLL SUPPORT BEARING	4	6	8	8	10		12
13	D31-0148	METER ROLL WASHER	8	12	16	16	20		24
14	D31-0046	METER ROLL SPI ICEF SHAFT	4	6	8	8	10		12
15	S-6368	COTTER PIN 1/8" DIA X 3/4" LONG	24	32	40	40	48		56
16	D31-0031	METERING ROLL 47 1/4"	4	2	2	4	2		2
	D31-0030	METERING ROLL 46 11/16"	2	4	6	6	8		10
	D31-0029	METERING ROLL 23 5/16"		2	2		2		2
17	D31-0120	DISCHARGE PLATE MOUNT	1	1	1	1	1		1
18	D01-0701	REAR AUGER	1						
	D01-0807	REAR AUGER		1	1		1		1
	D61-0184	REAR AUGER				1			
	D61-0327	REAR STUB AUGER				1			
	D31-0025	BEARING HANGER BRACKET				1			
	D31-0026	1 1/2" OIL IMPREGNATED WOOD BEARING				1			
	D31-0048	BEARING THRUST WASHER				1			
19	D01-0481	GRAIN DISCHARGE BOX	1	1	1	1	1		1
20	D31-0073	AUGER SHAFT GUARD	1	1	1	1	1		1
21	D01-0405	GRAIN SAMPLER	1	1	1	1	1		1
22	TAF-6007	AUGER LIMIT SWITCH HEAD	1	1	1	1	1		1
23	D03-0100	AUGER LIMIT SWITCH	1	1	1	1	1		1
24	D01-0527	SPEED SENSOR BOARD	2	2	2	2	2		2
25	FH-6972	4" X 4" HANDY BOX	2	2	2	2	2		2
26	D01-0272	METER ROLL STUB SHAFT 1"	2	2	2	2	2		2
27	D01-0451	MONITORING GEAR	2	2	2	2	2		2
28	D01-0462	SPEED SENSOR BOX BRACKET	2	2	2	2	2		2
29	D01-0043	BOTTOM ANGLE BRACKET REAR	1	1	1	1	1		1
30	S-7013	7/16"-14 X 2 1/2" HEXHEAD BOLT	8	8	8	12	12		12
31	D31-0062	TWO BOLT SPACER PLATE	1	1	1	2	1		1
32	D31-0063	SHIM, CENTER BEARING HANGER	1	1	1	2	1		1
33	D31-0064	SPACER PLATE, CENTER BEARING	1	1	1	2	1		1
34	D31-0025	BOTTOM AUGER BEARING HANGER	2	2	2	4	2		2
35	D31-0026	1 1/2" AUGER HANGER BEARING	1	1	1	2	2		2
36	D31-0048	HANGER BEARING THRUST WASHER	2	2	2	4	2		2
37	D31-0076	AUGER SPLICE SHAFT	1	1	1	2	2		2
38	S-7170	7/16"-14 LOCKNUT	4	4	4	12	12		12
39	S-836	HEX NUT 5/8"-11	4	4	4	4	4		4
40	S-858	FLAT WASHER 5/8"	4	4	4	4	4		4

STACK DRYERS
BOTTOM AUGER AND METERING ROLLS

REF NO.	PART NO.	DESCRIPTION	QTY					
			3312	3314	3318	3320	3322	3326
41	D01-0196	SPROCKET IDLER ASSEMBLY	2	2	2	2	2	2
42	D32-0002	WORM GEAR BOX 50:1 RIGHT ANGLE	1	1	1	1	1	1
43	D02-0004	MOTOR 3/4 HP DC 1750 TEFC 180 V	1	1	1	1	1	1
44	D02-0029	SPROCKET 40H30	2	2	2	2	2	2
45	D01-0006	METER ROLL DRIVESHAFT	2	2	2	2	2	2
46	D02-0007	BUSHING H-1	1	1	1	1	1	1
47	S-7011	5/8" X 3 1/2" BOLT	2	2	2	2	2	2
48	D01-0065	BEARING SHIELD SPACER	2	2	2	2	2	2
49	D31-0137	KEY 3/8" X 3/8" X 2 1/2"	1	1	1	1	1	1
50	D32-0019	BUSHING Q1 X 1 1/2"	1	1	1	1	1	1
51	D52-0001	SHEAVE 2TB160	1	1	1	1	1	1
52	D32-0001	FLANGETTE BEARING 1 1/2"	2	2	2	2	2	2
53	D31-0049	AUGER BEARING PLATE	1	1	1	1	1	1
54	D02-0002	FLANGETTE BEARING 1"	4	4	4	4	4	4
55	D01-0003	ADAPTOR PLATE	4	4	4	4	4	4
56	D31-0316	AUGER END SHAFT		1	1	1	1	1
57	D21-0017	FRONT AUGER	1	1				
	D01-0804	FRONT AUGER					1	
	D31-0092	FRONT AUGER			1	1		1
58	D31-0267	MIDDLE AUGER					1	1
59	D01-0268	SCR DRIVE BEARING SHIELD	1	1	1	1	1	1
60	D01-0688	HINGE	1	1	1	1	1	1
61	D31-0302	DISCHARGE AUGER TUBE	1	1	1	1	1	1

STACK DRYERS POWER AND CONTROL BOX

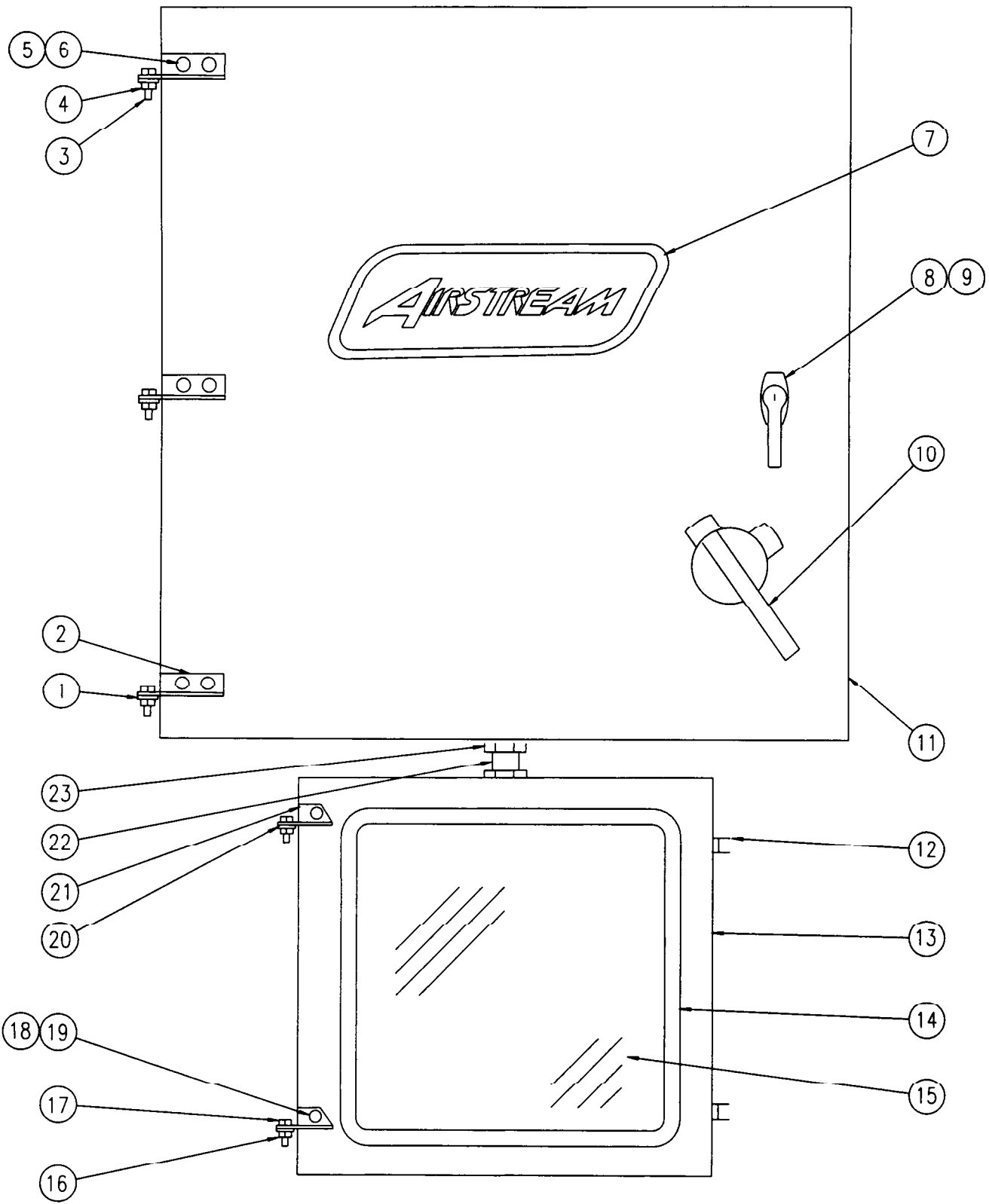

STACK DRYERS
POWER AND CONTROL BOX

REF NO.	PART NO.	DESCRIPTION	QTY					
			3312	3314	3318	3320	3322	3326
1	D01-0217	POWER BOX HINGE SEGMENT	2	2	2	2	2	2
2	D01-0216	POWER BOX DOOR, HINGE SEGMENT	2	2	2	2	2	2
3	S-4275	HEX HEAD BOLT 5/16" - 18 X 3/4"	2	2	2	2	2	2
4	S-5220	HEX LOCKNUT 5/16"-18	2	2	2	2	2	2
5	S-3550	CARRIAGE BOLT 5/16"- 18 X 1"	8	8	8	8	8	8
6	S-5220	HEX LOCKNUT 5/16"-18	9	8	8	8	8	8
7	DC-452	AIRSTREAM DECAL	1	1	1	1	1	1
8	D02-0034	DOOR HANDLE (LOCKING)	1	1	1	1	1	1
9	D02-0045	DOOR HANDLE GASKET	1	1	1	1	1	1
10	D01-0505	SAFETY DISCONNECT 230V 250 AMPS & UP	1	1	1	1	1	1
	D01-0520	SAFETY DISCONNECT 480V 250 AMPS & UP	1	1	1	1	1	1
	D03-0030	SAFETY DISCONNECT 225 AMPS & DOWN	1	1	1	1	1	1
11	D01-0540	POWER BOX DOOR (LARGE HANDLE)	1	1	1	1	1	1
	D01-0479	POWER BOX DOOR (SMALL HANDLE)	1	1	1	1	1	1
12	FH4429-1	SPRING LATCH	2	2	2	2	2	2
13	D01-0485	CONTROL BOX DOOR	1	1	1	1	1	1
14	D02-0036	WINDOW WEATHERSTRIP	1	1	1	1	1	1
15	D01-0517	CONTROL BOX WINDOW	1	1	1	1	1	1
16	S-5220	HEX LOCKNUT 5/16"-18	2	2	2	2	2	2
17	S-4275	HEX HEAD BOLT 5/16"-18 X 3/4"	2	2	2	2	2	2
18	S-3550	CARRIAGE BOLT 5/16"-18 X 1"	2	2	2	2	2	2
19	S-5220	HEX LOCKNUT 5/16"-18	2	2	2	2	2	2
20	D01-0509	CONTROL BOX HINGE SEGMENT	2	2	2	2	2	2
21	D01-0508	CONTROL BOX DOOR HINGE SEGMENT	2	2	2	2	2	2
22	D01-0654	GALVANIZED CONDUIT	1	1	1	1	1	1
23	D01-0511	COMPRESSION FITTING	2	2	2	2	2	2
	D01-0512	SEAL FOR FITTING	2	2	2	2	2	2

STACK DRYERS POWER BOX

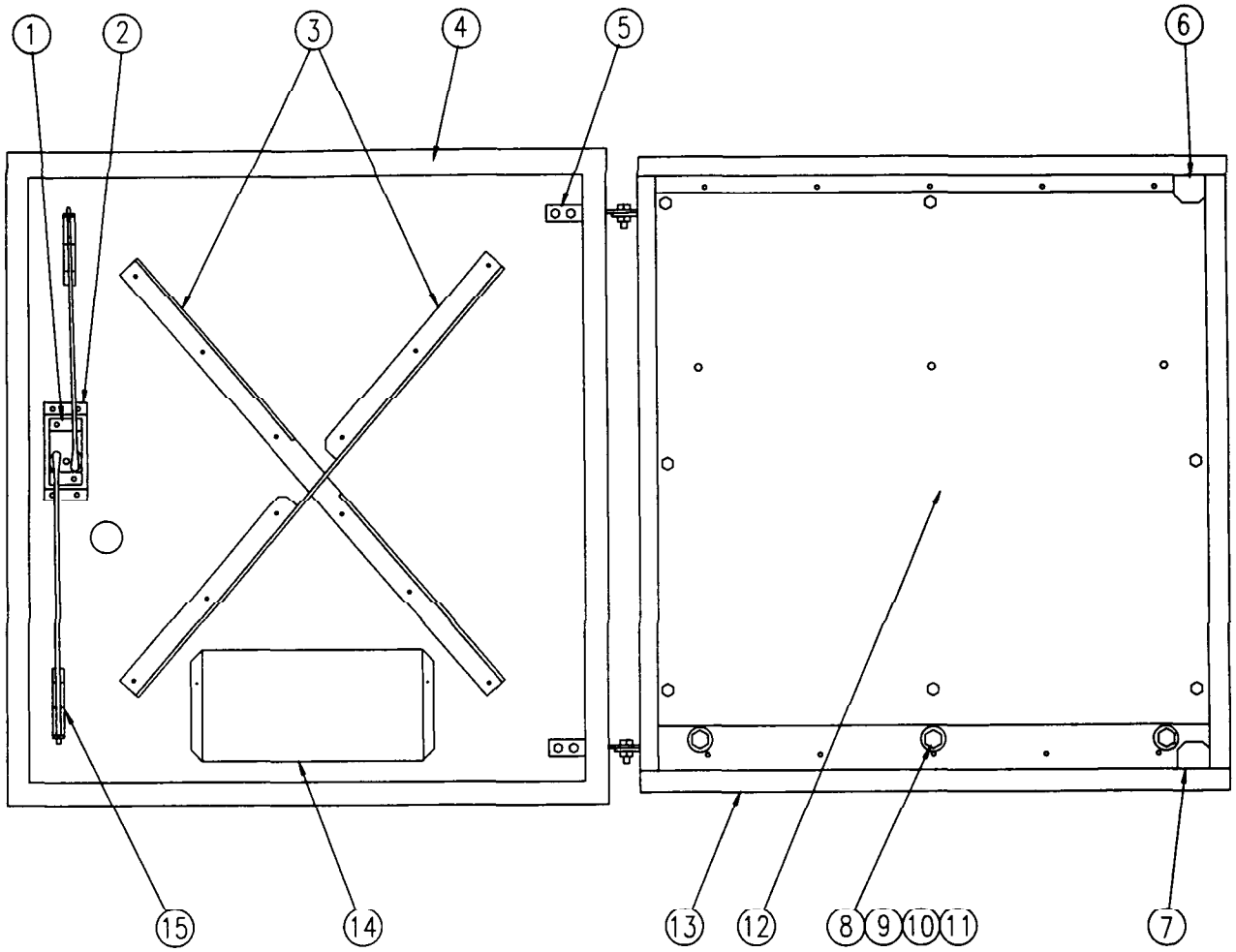

STACK DRYERS

POWER BOX

REF NO.	PART NO.	DESCRIPTION	QTY					
			3312	3314	3318	3320	3322	3326
1	D01-0547	POWER BOX DOOR LATCH MECHANISM	1	1	1	1	1	1
2	D01-0549	POWER BOX DOOR LATCH BRACKET	1	1	1	1	1	1
3	D01-0673	POWER BOX DOOR STIFFNERS	2	2	2	2	2	2
4	D02-0049	1/4" X 3/4" X 150" WEATHERSTRIP	1	1	1	1	1	1
5	D01-0215	BACK UP PLATE, POWER BOX DOOR HINGE	2	2	2	2	2	2
6	D01-0551	DOOR LATCH, CATCH ANGLE TOP	1	1	1	1	1	1
7	D01-0550	DOOR LATCH, CATCH ANGLE BOTTOM	1	1	1	1	1	1
8	S-6526	HEX HEAD BOLT 3/8"-16 X 2 1/4"	3	3	3	3	3	3
9	S-248	FLATWASHER 3/8"	12	12	12	12	12	12
10	S-456	3/8"-16 HEX NUT	6	6	6	6	6	6
11	D02-0043	RUBBER SHOCK MOUNT	6	6	6	6	6	6
12	D01-0480	POWER BOX BACK PANEL	1	1	1	1	1	1
13	D01-0478	POWER BOX	1	1	1	1	1	1
	D01-0476	BOTTOM	1	1	1	1	1	1
	D01-0477	TOP	1	1	1	1	1	1
14	D01-0212	OWNERS MANUAL HOLDER	1	1	1	1	1	1
15	D01-0548	STANDOFF BRACKET	2	2	2	2	2	2

STACK DRYERS

POWER BOX, 1 PHASE BACK PANEL

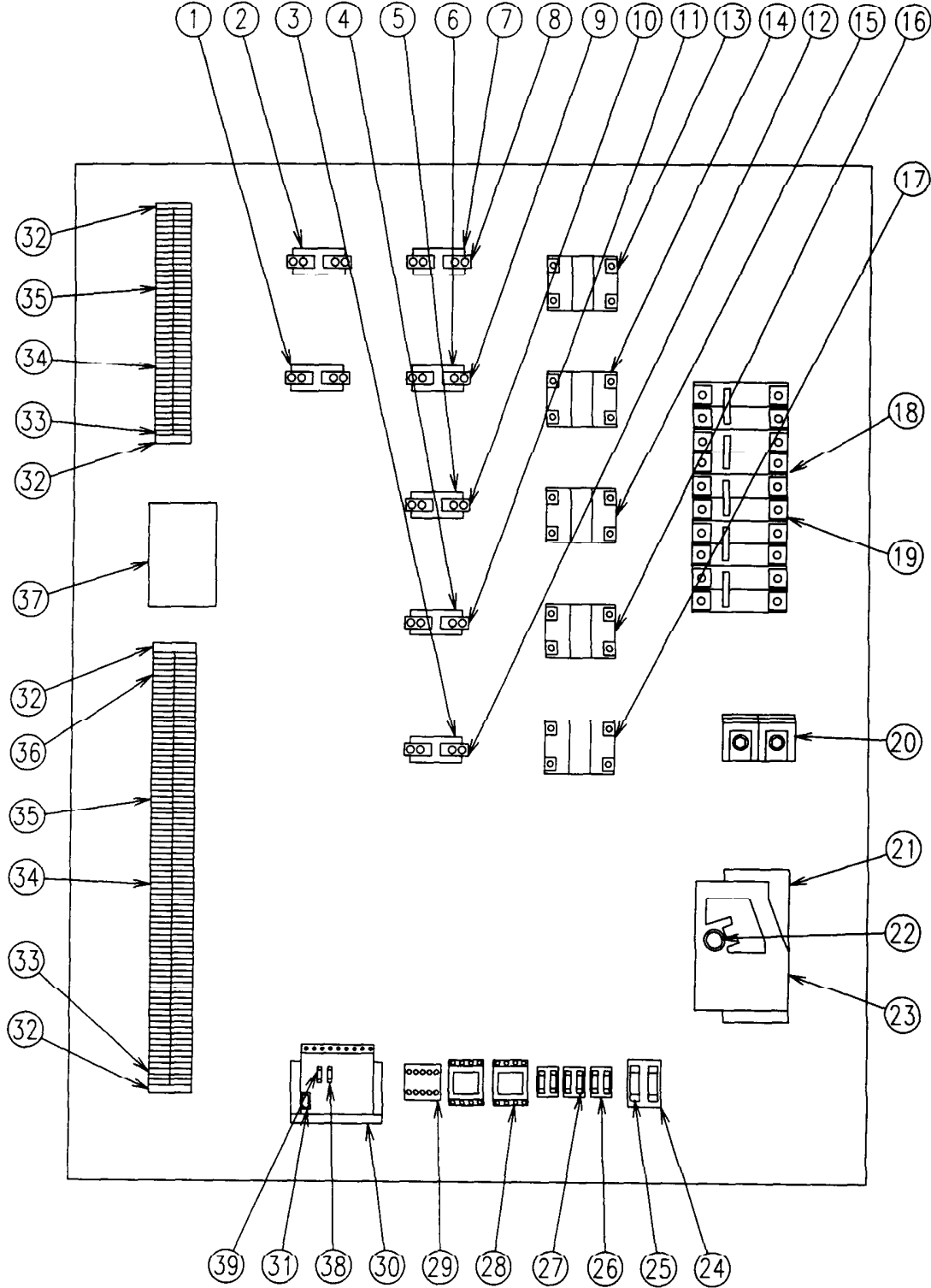

STACK DRYERS
POWER BOX, 1 PHASE BACK PANEL

REF NO.	PART NO.	DESCRIPTION	QTY	
			3312	3314
1,2	CH-1027	45 AMP OVERLOAD RELAY	1	1
3,4,5	FH-6335	90 AMP OVERLOAD RELAY	1	1
6,7	CH-1027	45 AMP OVERLOAD RELAY	1	1
8,9	FH-5443	C214B HEATER STRIP	1	
	FH-5447	C303B HEATER STRIP		1
10,11,12	FH-5738	F914B HEATER STRIP	1	1
13,14	HH-1162	60 AMP GE CONTACTOR	1	
	FH-5570	50-60 AMP 120V COIL	1	
	D54-0001	75 AMP GE CONTACTOR		1
	FH-5573	75-90 AMP 120V COIL		1
15,16,17	D03-0162	90 AMP GE CONTACTOR	1	1
	FH-5573	75-90 AMP 120V COIL	1	1
18	D04-0009	CIRCUIT BREAKER MOUNTING PLATE	5	5
19	D04-0003	100 AMP 2 POLE CIRCUIT BREAKER	5	5
20	D03-0105	POWER DISTRIBUTION BLOCK 2-POLE	1	1
21	D01-0492	400 AMP 1PH BREAKER	1	1
22	D03-0029	DISCONNECT EXTENSION SHAFT	1	1
23	D04-0007	1 PH DISCONNECT MECHANISM	1	1
24	D36-0003	FUSE HOLDER	2	2
25	D36-0002	FUSE 250V 5AMP	2	2
26	FH-1058	DOUBLE FUSE HOLDER	4	4
27	FH-1059	FUSE 250V 5AMP	8	8
28	D33-0003	MONITOR RELAY	2	2
	07097462	MONITOR RELAY BASE	2	2
29	D03-0106	SCR CONTACTOR	1	1
30	D03-0104	D.C. DRIVE BOARD	1	1
31	D33-0001	PLUG IN RESISTOR 3/4 H.P.	1	1
32	D01-0533	END STOP	4	4
33	D01-0532	BLANK END	2	2
34	D01-0531	TERMINAL BLOCK 4 MM GRAY		
	D03-0150	TERMINAL BLOCK 10 MM YELLOW		
	D03-0152	TERMINAL BLOCK 12 MM GRAY		
35	D03-0013	DIN RAIL	2	2
36	D01-0534	GROUND BLOCK	4	4
37	FH-3807	500 VA CONTROL TRANSFORMER	1	1
38	D03-0093	25 AMP FUSE	1	1
39	07098628	8 AMP FUSE	1	1

STACK DRYERS

POWER BOX, 3 PHASE BACK PANEL

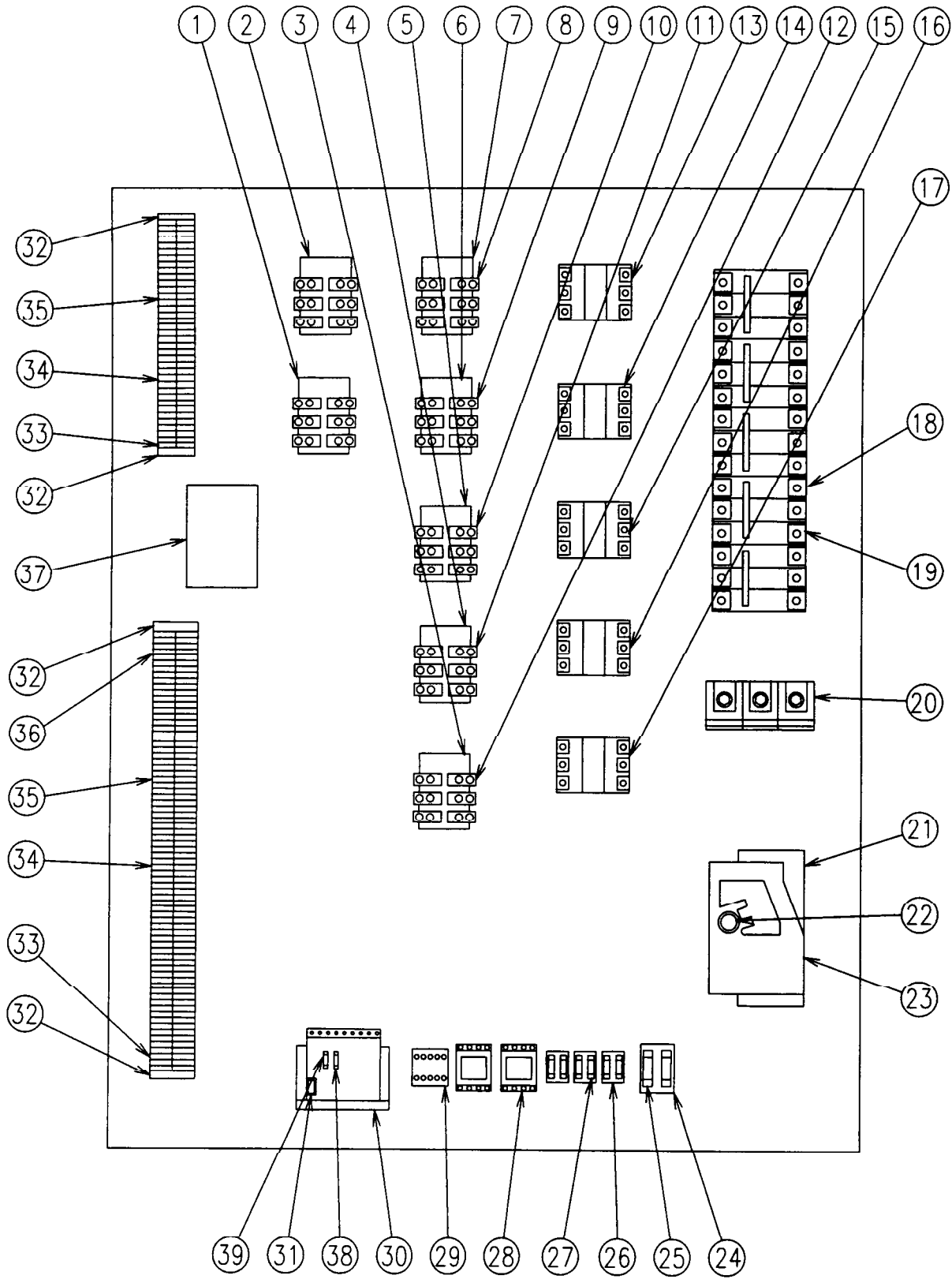

STACK DRYERS

POWER BOX, 3 PHASE BACK PANEL

REF NO.	PART NO.	DESCRIPTION	QTY					
			3312	3314	3318	3320	3322	3326
1,2	D05-0001	45 AMP 3 POLE OVERLOAD RELAY	1	1	1	1	1	1
3,4	D05-0001	45 AMP 3 POLE OVERLOAD RELAY	1	1	1	1	1	1
	TFC-0056	90 AMP 3 POLE OVERLOAD RELAY						1
5	D05-0001	45 AMP 3 POLE OVERLOAD RELAY	1	1				
	TFC-0056	90 AMP 3 POLE OVERLOAD RELAY			1	1	1	
	CH-5742	135 AMP 3 POLE OVERLOAD RELAY						1
6,7	D05-0002	27 AMP 3 POLE OVERLOAD RELAY	1	1	1	1	1	
	D05-0001	45 AMP 3 POLE OVERLOAD RELAY						1
8,9		C113B HEATER STRIP	3					
	FH-5440	C163B HEATER STRIP		3	3			
	FH-5444	C228B HEATER STRIP				3	3	
	FH-5447	C303B HEATER STRIP						3
10,11,12	FH-5739	C400B HEATER STRIP	3	3				
	FH-5452	F614B HEATER STRIP			3			
	FH-5454	F772B HEATER STRIP				3		
	FH-5738	F914B HEATER STRIP					3	
	FH-5740	F118C HEATER STRIP						3
13,14	D65-0004	50 AMP 3 POLE CONTACTOR	1	1	1			
	FH-5570	50-60 AMP 120 V COIL GE #55-B23A					1	1
	D05-0003	60 AMP 3 POLE CONTACTOR						
	FH-5570	50-60 AMP 120 V COIL GE#55-B23A						
	D65-0005	75 AMP 3 POLE CONTACTOR						1
	FH-5573	75-90 AMP 120 V COIL GE#55-B22A						
15,16,17	D05-0003	60 AMP 3 POLE CONTACTOR	1	1	1			
	FH-5570	50-60 AMP 120 V COIL GE#55-B23A					1	
	D65-0005	75 AMP 3 POLE CONTACTOR						
	FH-5573	75-90 AMP 120 V COIL GE#55-B22A						
	CH-5733	120 AMP 3 POLE CONTACTOR					1	1
	C-7216	120-150 AMP 120 V COIL						
18	D04-0009	CIRCUIT BREAKER MOUNTING PLATE	5	5	5	5	5	5
19	D35-0002	60 AMP 3 POLE CIRCUIT BREAKER	5	5	2			
	D65-0001	90 AMP 3 POLE CIRCUIT BREAKER			3	5	5	2
		125 AMP 3 POLE CIRCUIT BREAKER						3
20	D35-0001	POWER DISTRIBUTION BLOCK 3-POLE	1	1	1	1	1	1
21	D01-0498	200 AMP 240V BREAKER	1	1	1	1	1	
		500						1
22	D03-0029	DISCONNECT EXTENSION SHAFT	1	1	1	1	1	1
23	D05-0006	3 PHASE DISCONNECT MECHANISM	1	1	1	1	1	1
24	D36-0003	FUSE HOLDER	1	1	1	1	1	1
25	D36-0002	FUSE 250V 5AMP	2	2	2	2	2	2
26	FH-1058	DOUBLE FUSE HOLDER	3	3	3	3	3	3
27	FH-1059	FUSE 250V 5AMP	6	6	6	6	6	6
28	D33-0003	MONITOR RELAY	2	2	2	2	2	2
	07097462	MONITOR RELAY BASE	2	2	2	2	2	2
29	D03-0106	SCR CONTACTOR	1	1	1	1	1	1
30	D03-0104	D.C. DRIVE BOARD	1	1	1	1	1	1
31	D33-0001	PLUG IN RESISTOR 3/4 H.P.	1	1	1	1	1	1
32	D01-0533	END STOP	4	4	4	4	4	4
33	D01-0532	BLANK END	2	2	2	2	2	2
34	D01-0531	TERMINAL BLOCK 4 MM GRAY	70	70	70	70	70	70
	D03-0150	TERMINAL BLOCK 10 MM YELLOW	21	21	21	21	21	21
35	D03-0013	DIN RAIL	2	2	2	2	2	2
36	D01-0534	GROUND BLOCK	5	5	5	5	5	5
37	D01-0619	500 VA CONTROL TRANSFORMER	1	1	1	1	1	1
38	D03-0093	25 AMP FUSE	1	1	1	1	1	1
39	07098628	8 AMP FUSE	1	1	1	1	1	1

STACK DRYERS CONTROL BOX

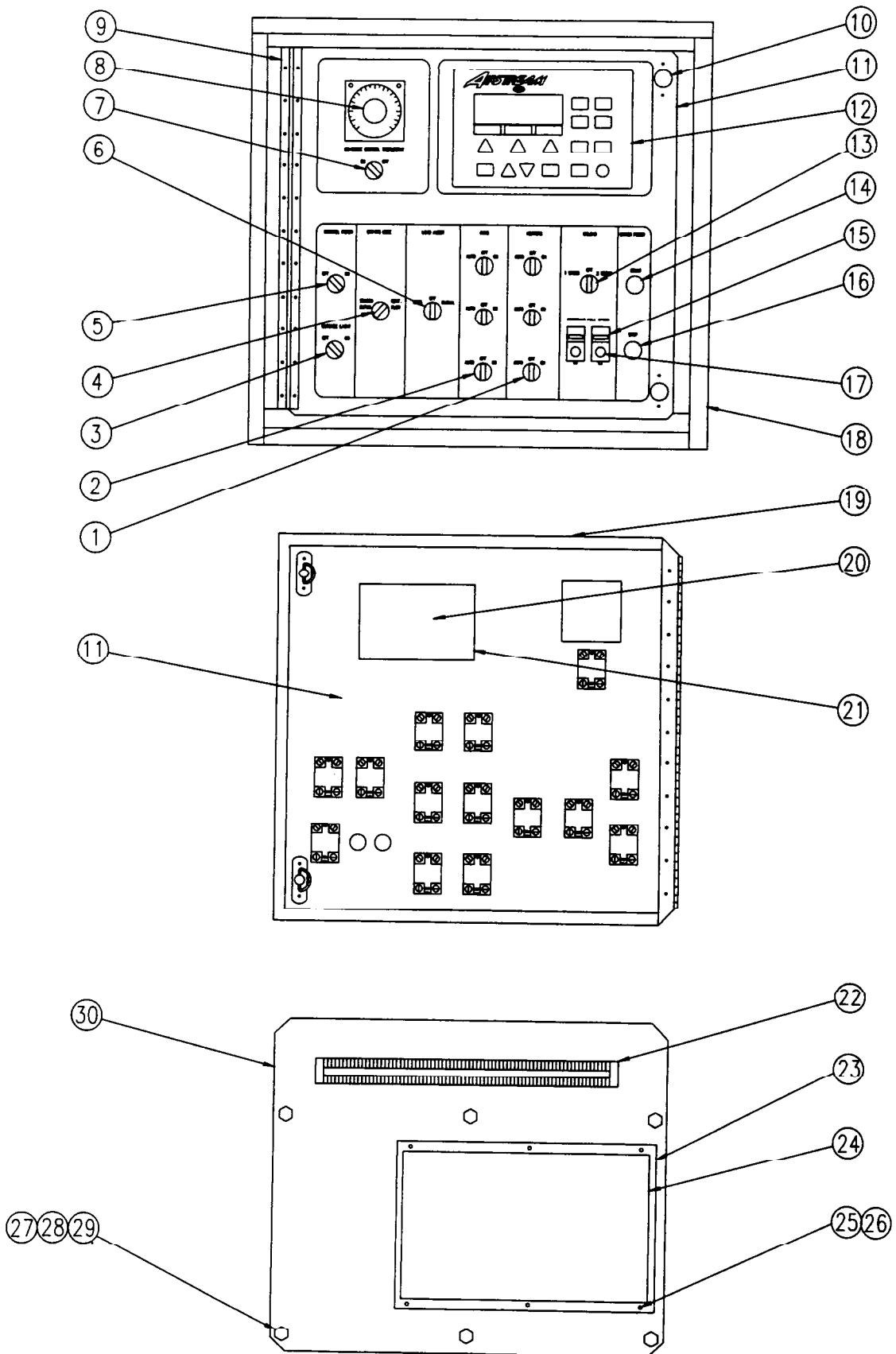

STACK DRYERS CONTROL BOX

REF NO.	PART NO.	DESCRIPTION	QTY					
			3312	3314	3318	3320	3322	3326
1	D63-0007	HEATER SWITCH	3	3	3	3	3	3
	D01-0447	LENSE FOR SWITCH	3	3	3	3	3	3
	D01-0455	120 VOLT LIGHT BULB SOCKET	3	3	3	3	3	3
2	D03-0124	120 VOLT LIGHT BULB	3	3	3	3	3	3
	D63-0007	FAN SWITCH	3	3	3	3	3	3
	D01-0449	LENSE FOR SWITCH	3	3	3	3	3	3
3	D01-0454	12 VOLT LIGHT BULB SOCKET	3	3	3	3	3	3
	D03-0125	12 VOLT LIGHT BULB	3	3	3	3	3	3
	D63-0005	OUTSIDE LIGHT SWITCH	1	1	1	1	1	1
	D01-0446	LENSE FOR SWITCH	1	1	1	1	1	1
	D01-0455	120 VOLT LIGHT BULB SOCKET	1	1	1	1	1	1
	D03-0124	120 VOLT LIGHT BULB	1	1	1	1	1	1
4	D63-0005	DRYING MODE SWITCH	1	1	1	1	1	1
	D01-0448	LENSE FOR SWITCH	1	1	1	1	1	1
	D01-0455	120 VOLT LIGHT BULB SOCKET	1	1	1	1	1	1
5	D03-0124	120 VOLT LIGHT BULB	1	1	1	1	1	1
	D63-0005	CONTROL POWER SWITCH	1	1	1	1	1	1
	D01-0446	LENSE FOR SWITCH	1	1	1	1	1	1
6	D01-0455	120 VOLT LIGHT BULB SOCKET	1	1	1	1	1	1
	D03-0124	120 VOLT LIGHT BULB	1	1	1	1	1	1
	D63-0007	LOAD AUGER SWITCH	1	1	1	1	1	1
	D01-0579	LENSE FOR SWITCH	1	1	1	1	1	1
	D01-0455	120 VOLT LIGHT BULB SOCKET	1	1	1	1	1	1
	D03-0124	120 VOLT LIGHT BULB	1	1	1	1	1	1
7	D63-0005	THERMOSTAT SWITCH	1	1	1	1	1	1
	D01-0444	LENSE FOR SWITCH	1	1	1	1	1	1
	D01-0454	12 VOLT LIGHT BULB SOCKET	1	1	1	1	1	1
8	D03-0125	12 VOLT LIGHT BULB	1	1	1	1	1	1
	D03-0041	MOISTURE CONTROL THERMOSTAT	1	1	1	1	1	1
9	D01-0583	HINGE, INNER DOOR 22 1/4"	1	1	1	1	1	1
10	TFH-2046	SOUTHCO SPRING LATCH WITH KNOB	2	2	2	2	2	2
11	D01-0521	CONTROL BOX FRONT PANEL	1	1	1	1	1	1
12	D03-0116	ELECTRONIC CONTROL SWITCH PANEL	1	1	1	1	1	1
13	D63-0007	UNLOAD SPEED SWITCH	1	1	1	1	1	1
	D01-0445	LENSE FOR SWITCH	1	1	1	1	1	1
	D01-0455	120 VOLT LIGHT BULB SOCKET	1	1	1	1	1	1
14	D03-0124	120 VOLT LIGHT BULB	1	1	1	1	1	1
	D03-0017	DRYER START BUTTON	1	1	1	1	1	1
	D01-0455	120 VOLT LIGHT BULB SOCKET	1	1	1	1	1	1
15	D03-0124	120 VOLT LIGHT BULB	1	1	1	1	1	1
	D03-0107	METERING ROLL POTENTIOMETER	2	2	2	2	2	2
16	D03-0020	DRYER STOP BUTTON	1	1	1	1	1	1
17	D03-0108	KNOB FOR POTENTIOMETER	2	2	2	2	2	2
18	D01-0482	CONTROL BOX	1	1	1	1	1	1
19	S-2052	1/8" X 1/2" X 68" WEATHERSTRIP	1	1	1	1	1	1
20	D03-0119	ELECTRONIC CONTROL DISPLAY MODULE	1	1	1	1	1	1
21	D03-0120	ELECTRONIC CONTROL MODULE	1	1	1	1	1	1
22	D03-0013	DIN RAIL	1	1	1	1	1	1
	D01-0531	TERMINAL BLOCK						
	D01-0532	BLANK END						
	D01-0533	END STOP						
23	D01-0534	GROUND BLOCK						
	D01-0542	CIRCUIT BOARD MOUNTING PLATE	1	1	1	1	1	1
24	D03-0121	CIRCUIT BOARD (INPUT OUTPUT)	1	1	1	1	1	1
25	S-6337	PAN HEAD SCREW 8-32 X 1/2"	6	6	6	6	6	6
26	S-6525	HEX NUT 8-32	6	6	6	6	6	6
27	S-2086	HEX HEAD BOLTS 3/8"-16 X 1 1/2"	6	6	6	6	6	6
28	S-248	FLAT WASHERS (5 EACH BOLT)	30	30	30	30	30	30
29	S-456	HEX NUT 3/8"-16	6	6	6	6	6	6
30	D01-0486	CONTROL BOX BACK PANEL	1	1	1	1	1	1

STACK DRYERS

FAN HEATER CONTROL BOX

REF NO.	PART NO.	DESCRIPTION	QTY	
			36"	42"
1	TD-100300	DPDT RELAY	1	1
	TD-100301	RELAY BASE DPDT	1	1
2	CH-5286	START RELAY (1 PHASE)		
3	CD-0184	CAPACITOR (1 PHASE)		
	TFH-2104	CAPACITOR (1 PHASE)		
	TFH-2105	CAPACITOR (1 PHASE)		
4	F-747	CAPACITOR RETAINER CLIP (1 PHASE)	1	1
	CD-0089	CAPACITOR CLAMP HALF (1 PHASE)	1	1
	CD-0090	CAPACITOR CLAMP HALF (1 PHASE)	1	1
5	D03-0013	MOUNTING RAIL	1	1
	D01-0532	BLANK END	1	1
	D01-0533	END STOP	1	1
	D03-0150	TERMINAL BLOCK 10 MM (YELLOW 3 PHASE)	3	3
	D03-0152	TERMINAL BLOCK 12 MM (GRAY 1 PHASE)	2	2
6	TFH-2013	8 POSITION TERMINAL STRIP	1	1
7	HF-4624	ELECTRONIC FLAME DETECTOR BOARD	1	1
8	CD-0009	CONTROL BOX ASSEMBLY	1	1
9	FH-7038	3/8" PVC		
10	FH-7050	3/8" PVC 90 DEG CONNECTOR	3	3
11	FH-7069	3/8" PVC 45 DEG CONNECTOR	1	1

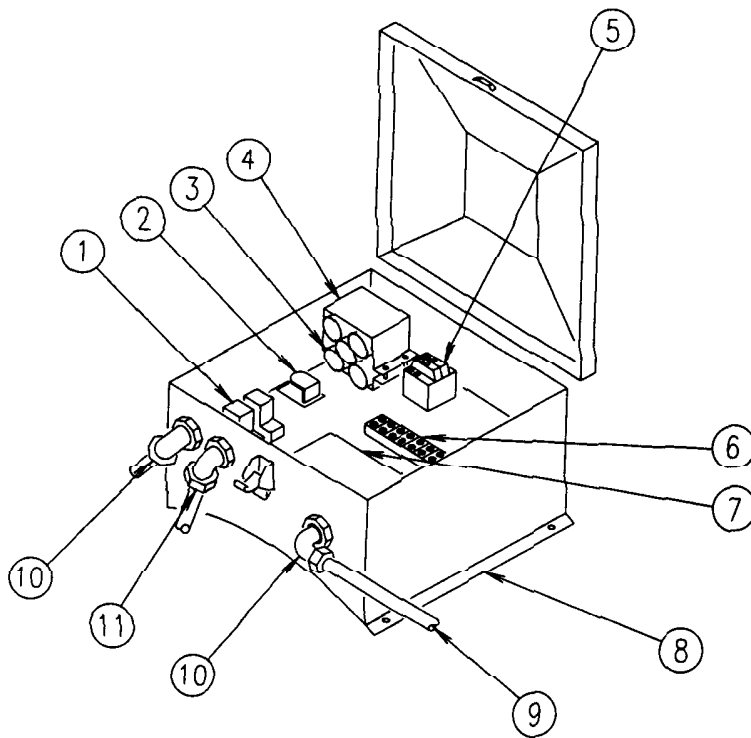

STACK DRYERS FAN HEATER

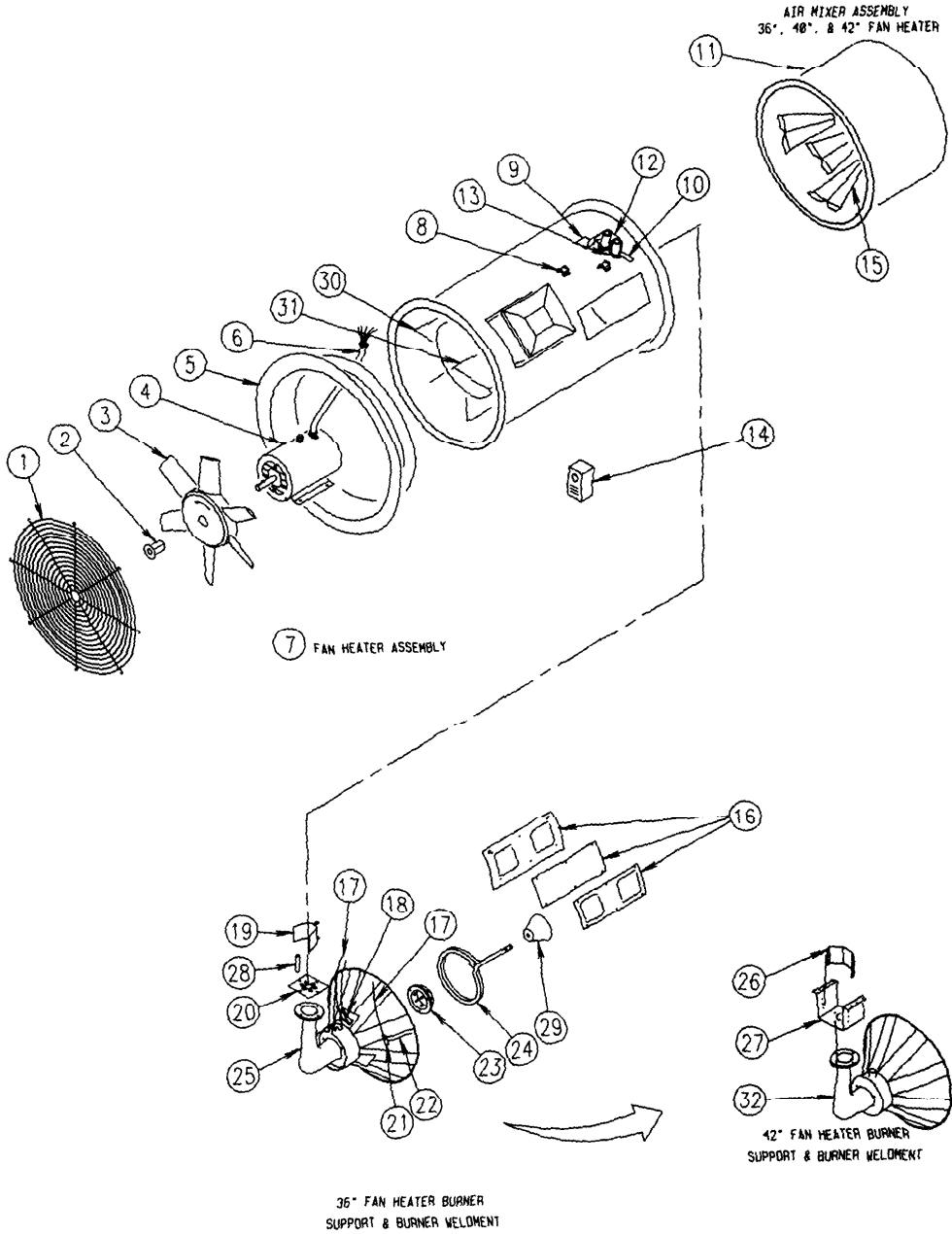

**STACK DRYERS
FAN HEATER**

REF NO.	PART NO.	DESCRIPTION	QTY	
			36"	42"
1	TFH-2002	36" GRILL GUARD	1	
	TFH-2003	42" GRILL GUARD		1
2	FH-1009	BUSHING 1 3/8" P2	1	
	FH-6963	BUSHING 1 5/8" P1		1
	CH-6386	BUSHING 1 5/8" Q1		1
	CH-6387	BUSHING 1 7/8" Q1		1
3	D01-0468	FAN PROPELLOR 10-12 HP		1
	D82-0002	FAN PROPELLOR 10-16 HP	1	
	D01-0469	FAN PROPELLOR 10-16 HP		1
	D01-0470	FAN PROPELLOR 20 HP		1
	D01-0471	FAN PROPELLOR 25 HP		1
	D01-0472	FAN PROPELLOR 30 HP		1
4	D01-0473	FAN PROPELLOR 40 HP		1
	CD-0110	10-12 HP 1 PH MOTOR	1	
	TFH-2054	10-16 HP 1 PH MOTOR		1
	CH-1050	15 HP 3 PH MOTOR		1
	CH-1051	20 HP 3 PH MOTOR		1
	C-2049	25 HP 3 PH MOTOR		1
	TFH-2011	30 HP 3 PH MOTOR		1
	CH-6848	40 HP 3 PH MOTOR		1
5	TFH-2004	36" VENTURI	1	
	TFH-2005	42" VENTURI		1
6	CD-0076	36" FAN SEAL-TITE ASSEMBLY	1	1
7	CD-0067	36" FAN HEATER ASSEMBLY	1	
	D61-0242	42" FAN HEATER ASSEMBLY		1
8	CD-0179	PIPETRAIN SUPPORT BRACKET	2	2
9	HF-7057	VAPORIZER ADJUSTMENT BRACKET (LP ONLY)	1	1
	HF-7091	VAPOR COVER PLATE (NATURAL GAS ONLY)	1	1
10	HF-7056	VAPORIZER PIVOT BRACKET (LP ONLY)	2	2
11	CD-0082	36" AIR MIXER SHROUD	1	
	CD-0192	42" AIR MIXER SHROUD		1
12	HF-7060	VAPORIZER SUPPORT WELDMENT (LP ONLY)	1	1
13	HH-7016	RUBBER GROMMET (LP ONLY)	2	2
14	D01-0672	AIR SWITCH BOX ASSEMBLY	1	1
	D03-0167	AIR SWITCH	1	1
15	CD-0083	AIR MIXER VANE	6	8
16	HF-6065	ACCESS PANEL ASSY.	1	1
	TFH-2046	SPRING LATCH W/ BLACK KNOB	2	2
	HF-6064	ACCESS PANEL	1	1
	HH-2020	PLASTIC WINDOW	1	1
	HF-2025	HEATER COVER PLATE	1	1
17	CD-0092	60" IGNITION WIRE ASSEMBLY	3	3
18	THH-4178	2 PRONG IGNITOR	1	1
	CD-0188	IGNITOR BRACKET	1	1
19	CD-0102	COLLECTOR & BURNER SUPPORT	1	

STACK DRYERS

FAN HEATER

REF NO.	PART NO.	DESCRIPTION	QTY	
			36"	42"
20	CD-0105	COLLECTOR PLATE	1	
21	CD-0187	FLAME PROBE MOUNTING BRACKET	1	1
22	THH-4179	FLAME SENSING PROBE	1	1
23	THF-3057	BURNER CUP	1	1
24	CD-0197	FORMED VAPORIZER COIL (LP ONLY)	1	
	HF-7207	FORMED VAPORIZER COIL (LP ONLY)		1
25	THF-3047	36" BURNER WELDMENT	1	
26	TF-1217	BURNER COLLECTOR CUP		1
27	TF-1216	BURNER SUPPORT BRACKET		1
28	CD-0103	BURNER SUPPORT PIPE	4	
29	HH-7056	BURNER CONE	1	1
30	CD-0104	AIR STRAIGHTENING VANES	6	8
31	CD-0068	MOTOR MOUNT 10 - 16 HP OR 15 HP	1	
	TF-1209	MOTOR MOUNT 10 - 16 HP		1
	TF-1208	MOTOR MOUNT 25 HP		1
	TF-1211	V - BRACE		1
32	THF-3028	42" BURNER WELDMENT		1

STACK DRYERS

36" LP FAN HEATER PIPETRAIN

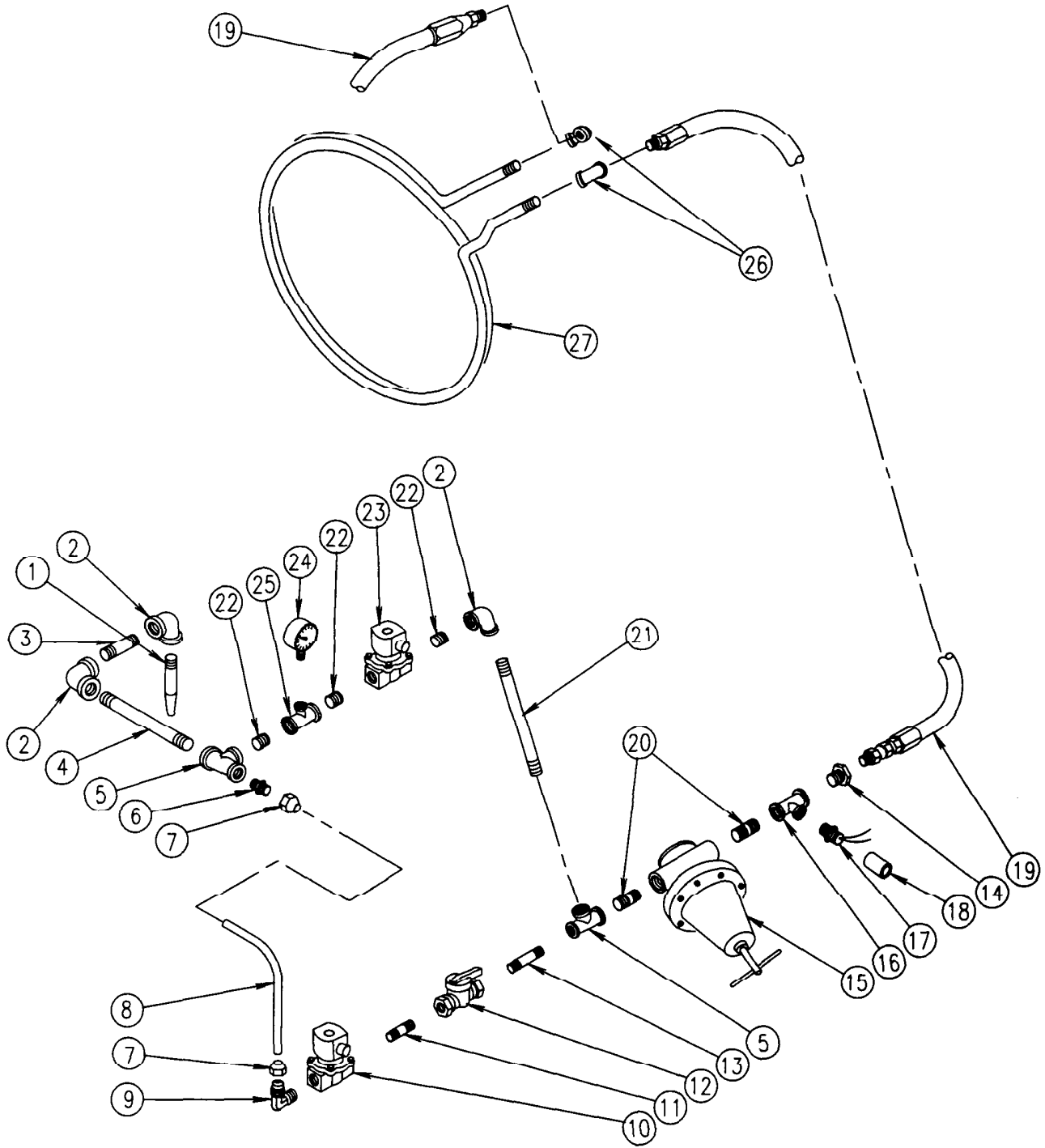

STACK DRYERS
36" LP FAN HEATER PIPETRAIN

REFERENCE NUMBER	PART NUMBER	DESCRIPTION	QTY PER FAN
1	CD-0150	36" PROPANE ORIFICE TUBE .3281" ORIFICE DIA. 10-16 HP	1
2	THH-4120	3/4" 90 DEG ELBOW, SCH 40 BLACK	3
3	THH-4136	3/4" X 3" NIPPLE, SCH 40 BLACK	1
4	HH-7030	3/4" X 10 1/2" NIPPLE, SCH 40 BLACK	1
5	D18-0002	3/4" X 1/2" X 3/4" TEE, SCH 40 BLACK	2
6	HH-1254	U1-8D MALE FLARE CONNECTOR	1
7	HH-1255	NS-4-8 FLARE NUT	2
8	CT-0050	1/2" X 7.5" COPPER TUBE	1
9	HH-1932	1/2" 90 DEG ELBOW, BRASS	1
10	TFC-0032	1/2" SOLENOID L.P. VALVE	1
	TFC-0086	ASCO REPLACEMENT COIL	
	TFC-0089	ASCO REPAIR KIT	
11	HH-2029	1/2" X 1 1/2" NIPPLE, SCH 40 BLACK	1
12	D02-0084	1/2" NPT BRASS BALL VALVE	1
13	THH-4128	1/2" X 2" NIPPLE, SCH 40 BLACK	1
14	D07-0028	3/4" X 1/2" HEX REDUCER BUSHING	1
15	TFC-0020	REGULATOR 3/4" 0-30 PSI	1
16	THH-4174	3/4" X 3/4" X 1/2" TEE, SCH 40 BLACK	1
17	HH-7013	VAPOR HI-LIMIT 200 DEG (SCREW IN TYPE)	1
18	HH-7031	1/2" COUPLER, SCH 80 BLACK	1
19	TFC-0095	1/2" HOSE ASSY.	2
20	D08-0026	3/4" X 1 1/2" NIPPLE, SCH 40 BLACK	2
21	D07-0030	3/4" X 7 3/4" NIPPLE, SCH 40 BLACK	1
22	THH-4121	3/4" CLOSE NIPPLE, SCH 40 BLACK	3
23	TFC-0081	3/4" SOLENOID L.P. VALVE	1
	TFC-0085	ASCO REPLACEMENT COIL	
	TFC-0089	ASCO REPAIR KIT	
24	HH-2984	1/4" 30 PSI PRESSURE GAUGE	1
25	THH-4154	3/4" X 3/4" X 1/4" TEE, SCH 40 BLACK	1
26	THH-4071	1/2" 90 DEG ELBOW, SCH 40 BLACK	2
27	HF-7183	VAPORIZER COIL (LP-GAS ONLY)	1

STACK DRYERS

42" LP FAN HEATER PIPETRAIN

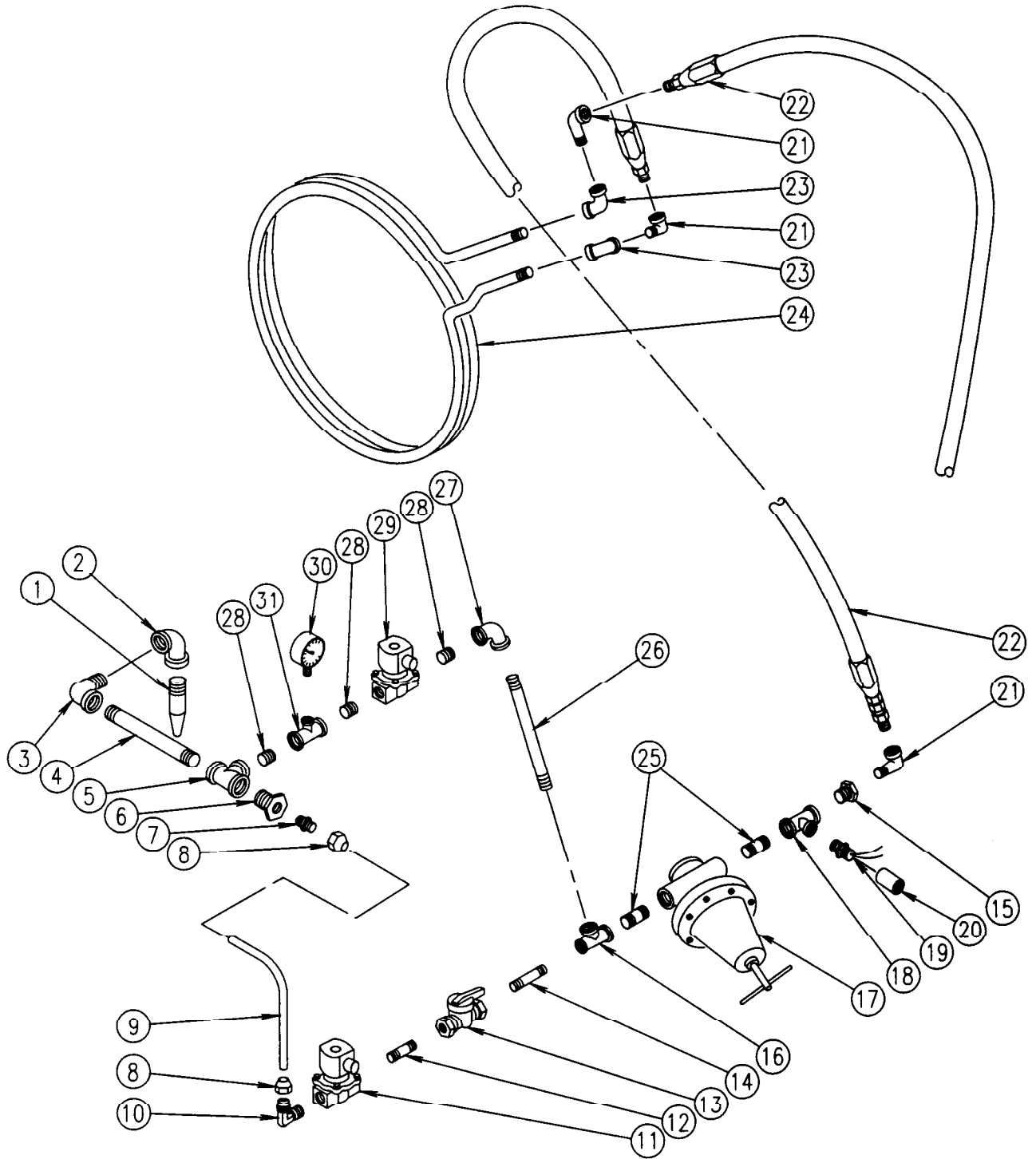

STACK DRYERS
42" LP FAN HEATER PIPETRAIN

REFERENCE NUMBER	PART NUMBER	DESCRIPTION	QTY PER FAN
1	THF-3242	36" PROPANE ORIFICE TUBE .2812" ORIFICE DIA. 10-12 HP	1
	CD-0150	36" PROPANE ORIFICE TUBE .3281" ORIFICE DIA. 10-16 HP	1
	CD-0183	40" PROPANE ORIFICE TUBE .3593" ORIFICE DIA. 25 HP	1
2	THH-4000	1" 90 DEG ELBOW, SCH 40 BLACK	1
3	THH-4164	1" 90 DEG STREET ELBOW, SCH 40 BLACK	1
4	THH-4183	1" X 10 3/4" NIPPLE, SCH 40 BLACK	1
5	D08-0017	1" X 1" X 3/4" TEE, SCH 40 BLACK	1
6	THH-4005	1" TO 1/2" HEX REDUCER BUSHING, SCH 40 BLACK	1
7	HH-1254	U1-8D MALE FLARE CONNECTOR	1
8	HH-1255	NS-4-8 FLARE NUT	2
9	CT-0050	1/2" X 7.5" COPPER TUBE	1
10	THH-4010	1/2" 90 DEG ELBOW, BRASS	1
11	TFC-0032	1/2" SOLENOID L.P. VALVE	1
	TFC-0085	ASCO REPLACEMENT COIL	
	TFC-0089	ASCO REPAIR KIT	
12	HH-2029	1/2" X 1 1/2" NIPPLE, SCH 40 BLACK	1
13	D02-0084	1/2" NPT BRASS BALL VALVE	1
14	THH-4128	1/2" X 2" NIPPLE, SCH 40 BLACK	1
15	D07-0028	3/4" TO 1/2" HEX REDUCER BUSHING	1
16	D18-0002	3/4" X 1/2" X 3/4" TEE, SCH 40 BLACK	1
17	TFC-0020	3/4" REGULATOR 0-30 PSI	1
18	THH-4174	3/4" X 3/4" X 1/2" TEE, SCH 40 BLACK	1
19	HH-7013	VAPOR HI-LIMIT 200 DEG (SCREW IN TYPE)	1
20	HH-7031	1/2" COUPLER SCH 80 BLACK	1
21	D07-0022	1/2" 90 DEG STREET ELBOW, SCH 40 BLACK	1
22	TFC-0095	1/2" HOSE ASSY.	2
23	THH-4071	1/2" 90 DEG, SCH 40 BLACK	2
24	HF-7207	VAPORIZER COIL (LP-GAS ONLY)	1
25	THH-4150	3/4" X 1 1/2" NIPPLE, SCH 40 BLACK	2
26	HH-7098	3/4" X 12" NIPPLE, SCH 40 BLACK	1
27	THH-4120	3/4" 90 DEG ELBOW, SCH 40 BLACK	1
28	THH-4121	3/4" CLOSE NIPPLE, SCH 40 BLACK	3
29	TFC-0081	3/4" SOLENOID LP VALVE	1
	TFC-0086	ASCO REPLACEMENT COIL	
	TFC-0089	ASCO REPAIR KIT	
30	HH-2984	1/4" 30 PSI PRESSURE GAUGE	1
31	THH-4154	3/4" X 3/4" X 1/4" TEE, SCH 40 BLACK	1

STACK DRYERS LP FUEL SUPPLY

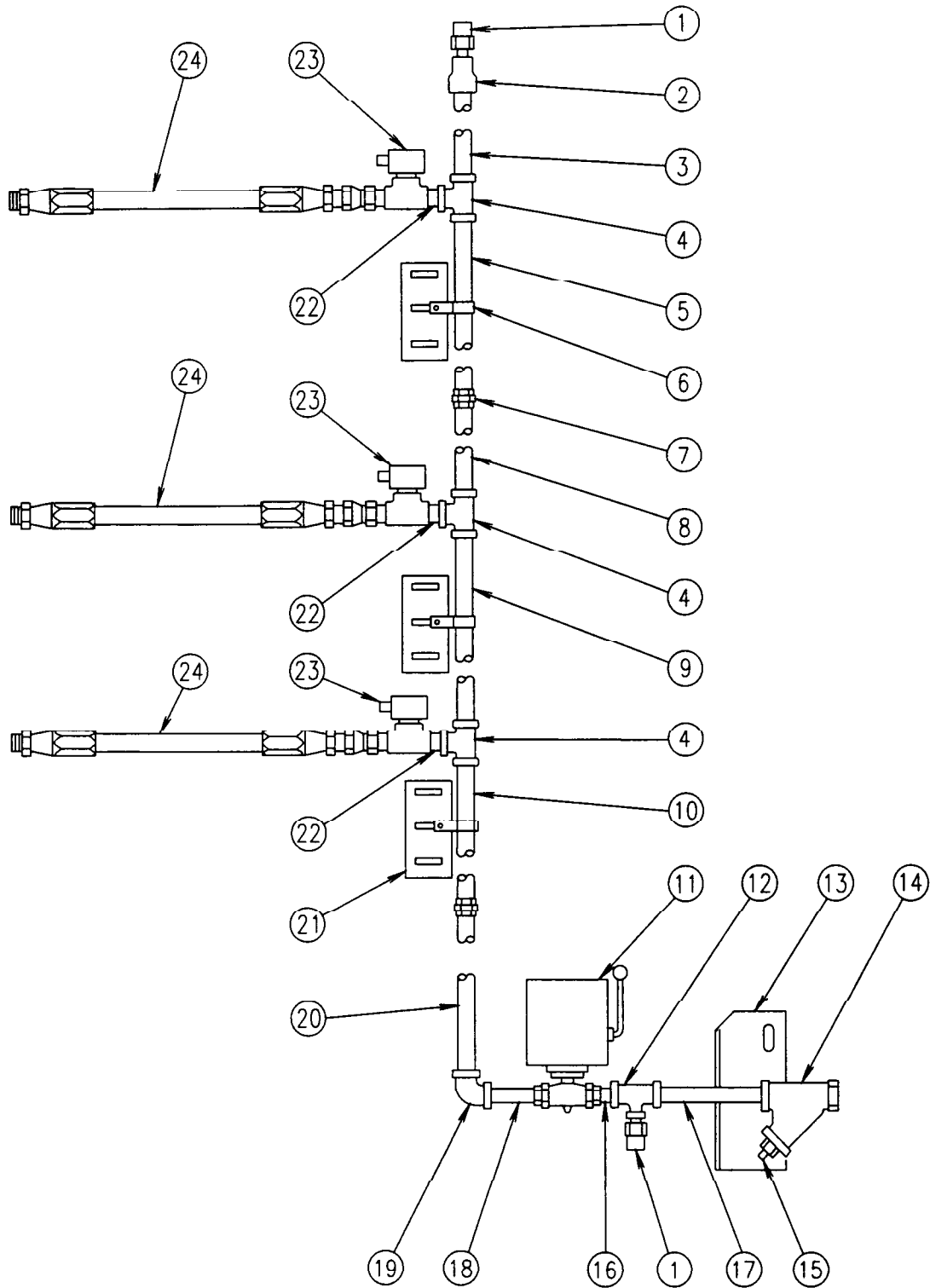

**STACK DRYERS
LP FUEL SUPPLY**

REFERENCE NUMBER	PART NO.	DESCRIPTION	QTY
1	HH-4845	1/4" NPT 250 PSI RELIEF VALVE	2
2	D67-0015	3/4" TO 1/4" BELL REDUCER, SCH 80 BLACK	1
3	D01-1017	3/4 X 25" NIPPLE, SCH 80 BLACK	1
4	HH-7036	3/4" X 3/4" X 1/2" TEE, SCH 80 BLACK	3
5	D01-0856	3/4" X 35" NIPPLE, SCH 80 BLACK	1
6	D62-0005	3/4" CONDUIT CLAMP	3
7	D67-0002	3/4" FEMALE UNION, SCH 80 BLACK	2
8	D01-1017	3/4" X 25" NIPPLE, SCH 80 BLACK	1
9	D67-0018	3/4" X 68" NIPPLE, SCH 80 BLACK	1
10	D01-1019	3/4" X 28" NIPPLE, SCH 80 BLACK	1
11	D28-0001	ELECTRIC SHUT OFF VALVE	1
12	D67-0001	3/4" X 3/4" X 1/4" TEE, SCH. 80 BLACK	1
13	D31-0075	GAS VALVE CARRIER BRACKET	1
14	D67-008	3/4" NPT STRAINER, SCH. 80	1
15	HH-1504	3/8" PIPE PLUG	1
16	HH-3683	3/4" X 1 1/2" NIPPLE, SCH 80 BLACK	1
17	D67-0016	3/4" X 8" NIPPLE, SCH 80 BLACK	1
18	D67-0017	3/4" NPT X 4" NIPPLE, SCH 80 BLACK	1
19	D67-0011	3/4" NPT 90 DEG ELBOW, SCH 80 BLACK	1
20	D01-1017	3/4" X 25" NIPPLE, SCH 80 BLACK	1
21	D31-0074	GAS MANIFOLD MOUNTING BRACKET	3
22	THH-1113	1/2" CLOSE NIPPLE SCH 80 BLACK	3
23	TFC-0092	1/2" NPT LIQUID SOLENOID VALVE	3
	TFC-0087	ASCO REPAIR KIT	
24	TFC-0085	ASCO REPLACEMENT COIL	
	TFC-0095	1/2" GAS HOSE ASSEMBLY	3

STACK DRYERS
36" & 42" NATURAL GAS FAN HEATER PIPETRAIN

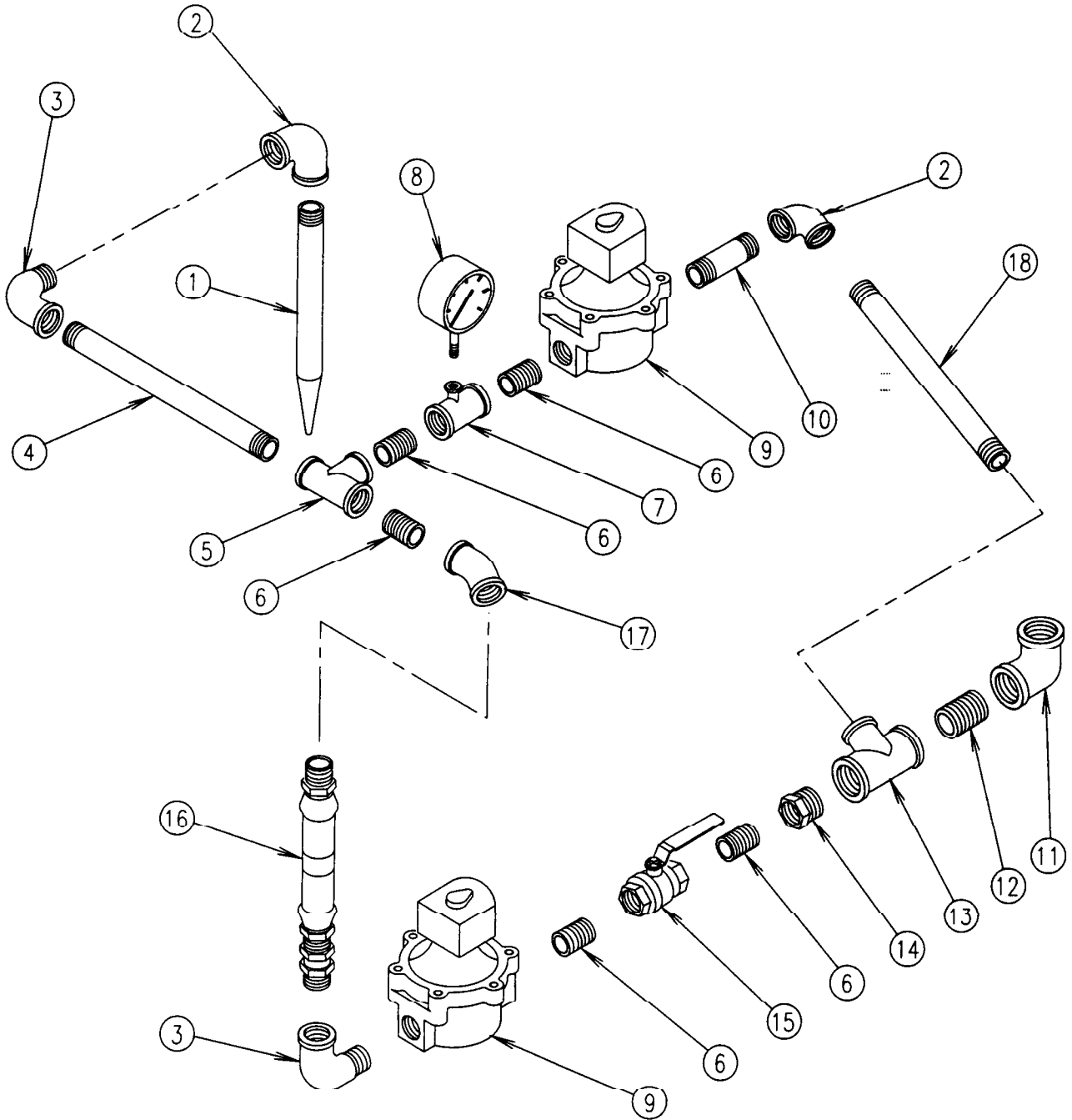

STACK DRYERS

36" & 42" NATURAL GAS FAN HEATER PIPETRAIN

REFERENCE NUMBER	PART NO.	DESCRIPTION	QTY PER FAN	
			36"	42"
1	TFH-3243	36" NAT. GAS ORIFICE TUBE .4062" DIA. 10-12 HP	1	
	THF-3244	36" NAT. GAS ORIFICE TUBE .5" DIA. 10-16 HP	1	
	THF-3246	42" NAT. GAS ORIFICE TUBE .5156" DIA. 10-16 HP		1
	THF-3248	42" NAT. GAS ORIFICE TUBE .5469" DIA. 20 HP		1
	THF-3250	42" NAT. GAS ORIFICE TUBE .5781" DIA. 25 HP		1
	THF-3251	42" NAT. GAS ORIFICE TUBE .5937" DIA. 30 HP		1
2	THF-3253	42" NAT. GAS ORIFICE TUBE .6406" DIA. 40 HP		1
	THH-4000	1" 90 DEG ELBOW, SCH 40 BLACK	2	2
3	THH-4164	1" 90 DEG STREET ELBOW, SCH 40 BLACK	2	2
4	THH-4183	1" X 10 3/4" NIPPLE, SCH 40 BLACK	1	1
5	THH-4137	1" X 1" X 1" TEE, SCH 40 BLACK	1	1
6	THH-4117	1" CLOSE NIPPLE, SCH 40 BLACK	5	5
7	THH-4152	1" X 1" X 1/4" TEE, SCH 40 BLACK	1	1
8	D08-0022	1/4" LOW PSI PRESSURE GAUGE	1	1
9	TFC-0031	1" SOLENOID GAS VALVE (ASCO)	2	2
	TFC-0082	REPAIR COIL (ASCO)		
	TFC-0090	REPAIR KITS (ASCO)		
10	THH-4151	1" X 3" NIPPLE, SCH 40 BLACK	1	1
11	D08-0011	1 1/2" 90 DEG ELBOW, SCH 40 BLACK	1	1
12	D08-0009	1 1/2" CLOSE NIPPLE, SCH 40 BLACK	1	1
13	D38-0001	1 1/2" X 1 1/2" X 1" TEE SCH 40 BLACK	1	1
14	D08-0007	1 1/2" X 1" HEX REDUCER	1	1
15	TFC-0093	1" BALL SHUT OFF VALVE	1	1
16	D68-0020	1" X 11" HOSE ASSEMBLY	1	1
17	HH-7038	1" 45 DEG ELBOW, SCH 40 BLACK	1	1
18	HH-7099	1" X 12 1/2" NIPPLE, SCH 40 BLACK	1	1

STACK MODEL DRYERS

NATURAL GAS FUEL SUPPLY

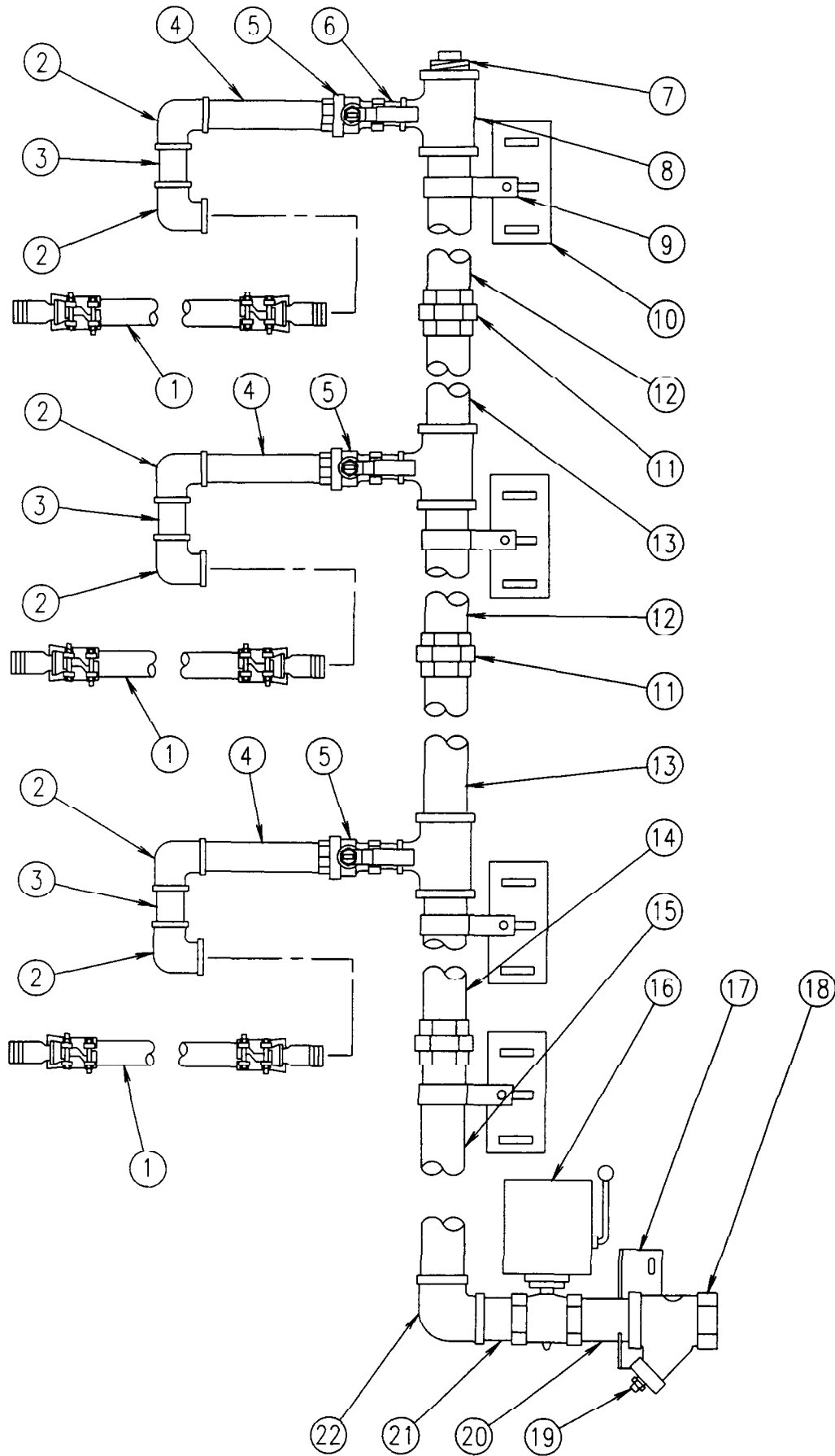

STACK DRYERS
NATURAL GAS FUEL SUPPLY

REFERENCE NUMBER	PART NUMBER	DESCRIPTION	QTY
1	D68-0019	1 1/2" X 36" LONG, MALE HOSE	3
2	D08-0011	1 1/2" 90 DEG ELBOW, SCH. 40 BLACK	6
3	D08-0001	1 1/2" X 6" NIPPLE SCH 40 BLACK	3
4	D08-0028	1 1/2" X 12" NIPPLE SCH 40 BLACK	3
5	D08-0008	1 1/2" SHUT OFF VALVE	3
6	D08-0009	1 1/2" CLOSE NIPPLE SCH. 40 BLACK	3
7	D68-0010	2 1/2" SQUARE PLUG SCH 40 BLACK	1
8	D68-0002	2 1/2" X 2 1/2" X 1 1/2" TEE SCH 40 BLACK	3
9	D62-0006	2 1/2" CONDUIT CLAMP	4
10	D31-0074	GAS MANIFOLD MOUNTING BRACKET	4
11	D68-0004	2 1/2" FEMALE UNION SCH 40 BLACK	3
12	HH-7090	2 1/2" X 36" NIPPLE SCH 40 BLACK	2
13	D68-0016	2 1/2" X 26" NIPPLE SCH 40 BLACK	2
14	D68-0021	2 1/2" X 57" NIPPLE SCH 40 BLACK	1
15	D01-1013	2 1/2" X 45" NIPPLE SCH 40 BLACK	1
16	D68-0015	2 1/2" ELECTRONIC SHUT-OFF VALVE	1
17	D51-0045	CARRIER BRACKET	1
18	D68-0011	2 1/2" Y STRAINER, SCH. 40 BLACK	1
19	D08-0014	1" PIPE PLUG, SCH. 40 BLACK	1
20	D68-0018	2 1/2" X 9" NIPPLE SCH 40 BLACK	1
21	D68-0012	2 1/2" X 4" NIPPLE SCH 40 BLACK	1
22	D68-0014	2 1/2" 90 DEG ELBOW SCH 40 BLACK	1

AIRSTREAM GRAIN CONDITIONING SYSTEMS

AIRSTREAM
A MEMBER OF
THE GSI GROUP



1004 E. Illinois St., Box 20
Assumption, IL 62510-0020
phone: 217-226-4421
fax: 217-226-4498