

BEFORE INSTALLATION:

1. Make sure the shaft, Bushing barrel and bore, Q-D® bushed product bore, key and keyway are free of burrs, paint etc. Make sure the key, as applicable, will slide in both shaft keyseat and Bushing bore keyway.



⚠ WARNING

Disconnect power before installation and maintenance. Failure to do so can result in severe injury or death.

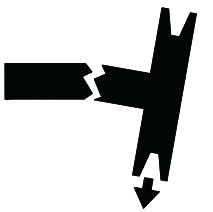

⚠ CAUTION

To avoid damage, supporting structure including shafts and bearings must be designed to handle transmitted loads and belt tension(s).

2. For proper operation, make sure the shaft size is within the size limits shown in Table 1. Some applications may benefit from tighter shaft tolerances.



⚠ WARNING

Lubricant on bushing barrel, hub or screws could lead to breakage.

⚠ CAUTION

Mounting a Q-D® Bushing on a shaft smaller than the size limits shown in Table 1 may result in a faulty assembly. The assembly may come off the shaft or undesirable assembly runout may result.

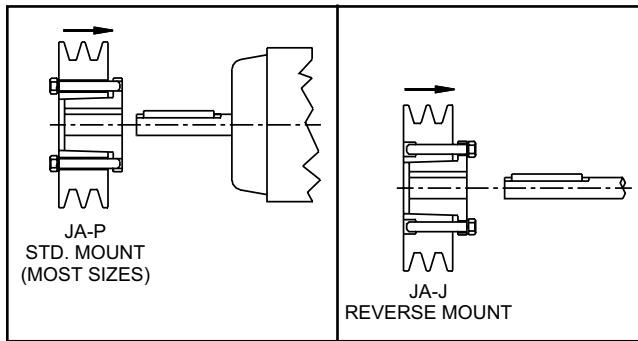

ILLUSTRATION 1A -- QD ASS'Y, FLANGE INBOARD

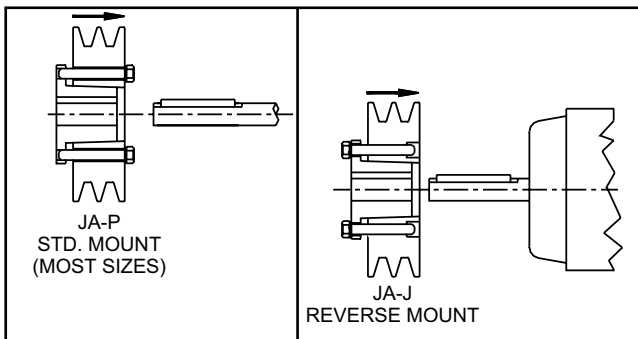

ILLUSTRATION 1B -- QD ASS'Y. FLANGE OUTBOARD

MOUNTING:

3. For light weight Products, the Bushing may first be loosely installed into the Q-D® bored product, hereafter referred to as "Product", and then the assembly slid onto the shaft (Illustration 1A and B). For heavier Products, it is usually easier to either first slide the Bushing onto the shaft, then slide the Product onto the Bushing (Illustration 2A), or first position the Product over the shaft, next slide the Bushing onto the shaft, and then pull the Product onto the Bushing (Illustration 2B). The "light weight Products" method is common, however if the Bushing barrel has collapsed, it must be wedged open (described below), and the "heavy Product" procedure may be easier.

Heavier Product may require a hoist or other means of holding the Product in position until the Bushing is inserted into the Product. When mounting on a vertical shaft, make sure the Bushing and the Product do not drop during installation.

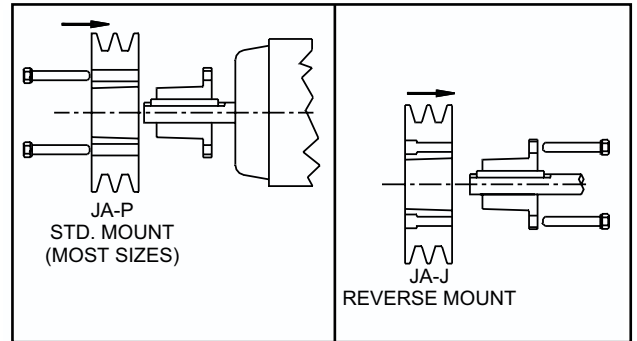

ILLUSTRATION 2A -- QD COMPONENTS, FLANGE INBOARD

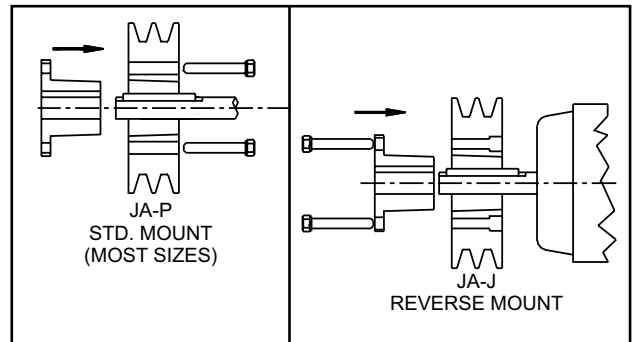

ILLUSTRATION 2B -- QD COMPONENTS, FLANGE OUTBOARD

4. It may be necessary to slightly wedge open the saw slot on some Bushings in order to start the bore and position the bushing onto the shaft. A narrow edged regular screw driver may be used.

⚠ CAUTION

Excessive wedging forces in Bushing saw slot may damage or break Bushing. AVOID.

5. Align the shaft keyseat as applicable with the Bushing bore keyway and install the key. Make sure the key runs the entire length of the Bushing bore.
6. For standard Q-D mounting, align the non-threaded holes in the Product with the threaded holes in the Bushing flange. For reverse Q-D mounting, align the non-threaded holes in the Bushing flange with the threaded holes in the Product. See illustration below. Some Q-D Products can only be reverse mounted. Insert the cap screws and thread them by hand three or four turns.

INSTALLATION

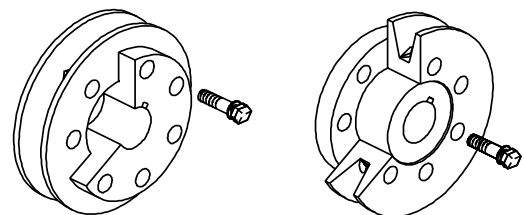

Reverse Mount

Std. Mount

Q-D® INSTRUCTIONS (Cont'd.)

- Position the Bushing - Product assembly axially on the shaft such that it is aligned with its running mate. Be sure to check for adequate clearance between the assembly and other nearby components if applicable. If the Bushing has a set screw over the keyway, tighten it to the torque value in Table 2.

CAUTION Tightening the set screw to a torque higher than shown in Table 2 may lead to Bushing damage or breakage. AVOID.

- If the Bushing - Product assembly is not between the shaft bearings, then locating the assembly closer to a bearing will reduce the load and increase the life of both bearings. Check for adequate clearance as stated in Step 7.
- Using a torque wrench and appropriate socket, tighten the cap screws with lock washers sequentially until each is tightened to the torque shown in Table 2. When the cap screw torque is at or near recommended torque, make at least two more sequential rounds to assure all cap screws are at the Table 2 cap screw torque value.

CAUTION Tightening the cap screws to a torque higher than shown in Table 2 may lead to Bushing damage or breakage. AVOID.

- If cap screws are provided with the Product, use them instead of the ones provided with the Bushing.

CAUTION Failure to use the cap screws that came with the Product may lead to an unsafe assembly.

- Since tightening the cap screws may affect the axial position of the Product, confirm that it is still properly aligned with its running mate. If not, determine how much the assembly must be moved to be in proper alignment.
- If axial adjustment is required, (following REMOVAL procedure), reposition the assembly and repeat step 9.
- Check installation gap - There must be a gap between the Bushing flange and the Product face. If there is no gap between them, disassemble the parts (following REMOVAL procedure) and determine the reason(s) for the faulty assembly.

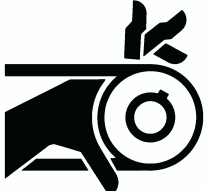

WARNING

Operating drives without guards in place can result in severe injury or death.

REMOVAL:

- Heavier Product may require a hoist or other means of supporting the Product during the removal procedure. When removing from a vertical shaft, make sure the Bushing and Product do not drop during removal.
- Remove all cap screws sequentially. If the Bushing has a keyway set screw, loosen it.
- For standard Q-D removal, insert cap screws into all threaded holes in Product. For reverse Q-D removal, insert cap screws into all threaded holes in bushing flange. In both cases, insert the removal screws from the same side of the assembly, wherever possible, from which the cap screws were just removed. See Illustration below.

REMOVAL

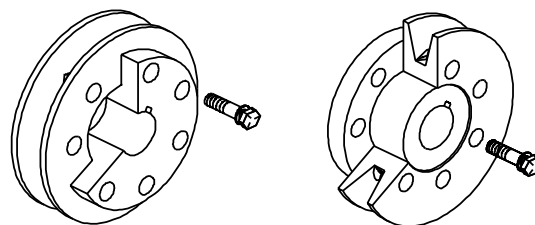

Reverse Removal

Std. Removal

- Tighten the cap screws against the face until the screw force releases the Product from the Bushing.
- Remove the Bushing and Product from the shaft using appropriate means.

Table 1
SHAFT SIZE LIMITS FOR Q-D® BUSHINGS

| Shaft Size Range (IN) | | Lower Shaft Size Limit (IN) | Shaft Size Range (MM) | | Lower Shaft Size Limit (MM) Above |
|-----------------------|-------|-----------------------------|-----------------------|-------|-----------------------------------|
| Through | Above | | Through | | |
| - | 1 1/2 | -0.003 | - | 38.1 | -0.076 |
| 1 1/2 | 2 1/2 | -0.004 | 38.1 | 63.5 | -0.102 |
| 2 1/2 | 4 | -0.005 | 63.5 | 101.6 | -0.127 |
| 4 | 6 | -0.006 | 101.6 | 152.4 | -0.152 |
| 6 | 8 | -0.007 | 152.4 | 203.2 | -0.178 |
| 8 | 9 | -0.008 | 203.2 | 228.6 | -0.203 |
| 9 | - | -0.009 | 228.6 | - | -0.229 |

Note: Upper limit is + 0 whether units are INCHES OR MILLIMETERS.

Table 2
TIGHTENING TORQUES

| Bushing | SAE Grade 5.1 or 5 Cap Screw | | Cap Screw Torque | | | Set Screw Size | Set Screw Torque | | |
|-----------|------------------------------|-------------|------------------|----------|---------|----------------|------------------|----------|---------|
| | No. | Size | (In-Lbs) | (Ft-Lbs) | (N - M) | | (In-Lbs) | (Ft-Lbs) | (N - M) |
| JA | 3 | #10 - 24NC | 60 | 5 | 6.8 | — | — | — | |
| SH-SDS-SD | 3 | 1/4 - 20NC | 108 | 9 | 12.2 | 1/4 - 20NC | 87 | 7.25 | 9.8 |
| SK | 3 | 5/16 - 18NC | 180 | 15 | 20.3 | 1/4 - 20NC | 87 | 7.25 | 9.8 |
| SF | 3 | 3/8 - 16NC | 360 | 30 | 40.7 | 5/16 - 18NC | 165 | 13.8 | 18.6 |
| E | 3 | 1/2 - 13NC | 720 | 60 | 81.4 | 3/8 - 16NC | 290 | 24.2 | 32.8 |
| F | 3 | 9/16 - 12NC | 900 | 75 | 101.7 | 3/8 - 16NC | 290 | 24.2 | 32.8 |
| J | 3 | 5/8 - 11NC | 1620 | 135 | 183.1 | 3/8 - 16NC | 290 | 24.2 | 32.8 |
| M | 4 | 3/4 - 10NC | 2700 | 225 | 305.1 | 3/8 - 16NC | 290 | 24.2 | 32.8 |
| N | 4 | 7/8 - 9NC | 3600 | 300 | 406.8 | 1/2 - 13NC | 620 | 51.7 | 70.1 |
| P | 4 | 1 - 8NC | 5400 | 450 | 610.2 | 1/2 - 13NC | 620 | 51.7 | 70.1 |

(N-M) = Newton Meters

Have questions? Contact Technical Services at 1-800-626-2093.

The trademark Q-D® is a registered trademark of Emerson Electric Co.

Form #F20-23G 5/8/00
Printed in U.S.A.

© Emerson Power Transmission Manufacturing, L.P. 1998, 1999, 2000.
All Rights Reserved.

BROWNING
Emerson Power Transmission
MAYSVILLE, KENTUCKY 41056